	Owner's Manual Cargo Hook Kit	Document Number 120-224-00	Revision 5
		Date 07/01/24	Page 1 of 39

Owner's Manual Cargo Hook Kits

on

**UH-60A, EH-60A, HH-60L,
S-70A, S-70C, S-70M
Model Helicopters**

STC SR02698SE

Onboard Systems International, LLC
13915 NW 3rd Court
Vancouver, WA 98685 United States of America
Cage Code: 1Y921

Toll Free Phone: (800) 275-0883
Phone: (360) 546-3072

Applicable Equipment Part Numbers

200-437-00
200-438-00
200-438-01

**[Please check our web site www.onboardsystems.com](http://www.onboardsystems.com)
[for the latest revision of this manual.](#)**

	Owner's Manual Cargo Hook Kit	Document Number 120-224-00	Revision 5
		Date 07/01/24	Page 2 of 39

Record of Revisions

Revision	Date	Page(s)	Reason for Revision
0	02/24/2020	All	Initial Release
1	06/23/2020	All	General updates per prototype installation.
2	04/20/2022	1, 4, 5	Added EH-60A and HH-60L models.
3	03/10/2023	All	Incorporated S-70 models and associated new kit P/N 200-438-01 parts and instructions.
4	10/27/2023	9, 10, 23, 31	Replaced C-40 Indicator P/N 210-293-00 with P/N 210-293-01 to reflect new production kits.
5	07/01/24	12, 31	Updated primary release schematic (Figure 4.1.1) to correct representation of aircraft-side schematic and to correct Hook Open Switch wire terminations. Updated Installation Check-out to include instructions to enter the load cell's Cal Code into the C-40 Indicator.

Register Your Products for Automatic Notifications

Onboard Systems offers a free notification service via fax or email for product alerts and documentation updates. By registering your Onboard Systems products at our website, we will be able to contact you if a service bulletin is issued, or if the documentation is updated.

You can choose to receive notices on an immediate, weekly, or monthly schedule via fax, email or both methods. There is no charge for this service. Please visit our website at <https://www.onboardsystems.com/document/notify> to get started.



	Owner's Manual Cargo Hook Kit	Document Number 120-224-00	Revision 5
		Date 07/01/24	Page 3 of 39

Table of Contents

1.0	Introduction	4
1.1	Scope.....	4
1.2	Safety labels	4
2.0	Referenced Documents	4
3.0	System Overview	5
3.1	Description.....	5
3.2	Surefire Release	8
3.3	Bill of Materials	9
3.4	Specifications.....	10
4.0	Installation	11
4.1	Electrical Wiring Installation.....	11
4.1.1	Primary Electrical Release	11
4.1.2	Backup Electrical Release Wiring	13
4.2	Load Weigh System Installation	19
4.2.1	Doubler Installation.....	19
4.2.2	Load Indicator Installation	23
4.2.3	Load Weigh Harness Installation.....	23
4.2.4	Load Weight System Dust Cap Receptacle Installation.....	24
4.3	Cargo Hook Installation	26
4.4	Placards.....	28
4.5	Installation Check-out	29
4.6	Component Weights	31
4.7	Paper Work.....	31
5.0	Operation Instructions.....	32
5.1	Cargo Hook Loading.....	32
5.2	Cargo Hook Rigging	33
5.2.1	Nylon Type Straps and Rope	33
6.0	Maintenance	36
6.1	Instructions for Returning Equipment to the Factory.....	36
7.0	Certification	37

	Owner's Manual Cargo Hook Kit	Document Number 120-224-00	Revision 5
		Date 07/01/24	Page 4 of 39

1.0 Introduction

1.1 Scope

This owner's manual contains instructions for installation and operation of Cargo Hook Kits on the UH-60A, EH-60A, HH-60L, S-70A, S-70C, and S-70M model helicopters (refer to STC AML for approved type certificates).

1.2 Safety labels

The following definitions apply to safety labels used in this manual.



Indicates a hazardous situation which, if not avoided, will result in death or serious injury.



Indicates a hazardous situation which, if not avoided, could result in death or serious injury.



Indicates a hazardous situation which, if not avoided, could result in minor or moderate injury.



Draws the reader's attention to important or unusual information not directly related to safety.



Used to address practices not related to personal injury.

2.0 Referenced Documents

121-066-00	RFM Supplement
122-032-00	Component Maintenance Manual
123-046-00	ICA Manual
120-152-00	Owner's Manual, C-40 Indicator

	Owner's Manual Cargo Hook Kit	Document Number 120-224-00	Revision 5
		Date 07/01/24	Page 5 of 39

3.0 System Overview

3.1 Description

The P/N 200-437-00, 200-438-00 and 200-438-01 cargo hook kits serve as replacement hook kits for the existing Breeze/Aeroquip cargo hook (P/N FE7590-173) on these helicopters. They include the cargo hook, an electrical harness to connect to the helicopter's existing fixed cargo hook primary electrical release system, electrical components to adapt the helicopter's existing squib system to the backup quick release system of the new cargo hook, and an optional load weigh system.



The cargo hook's backup electrical release system draws a 12.- amp intermittent load and must be installed on the DC essential bus. It is the responsibility of the installer to ensure that there is adequate capacity for this load.

Kit P/N 200-438-00 is the same as P/N 200-437-00 except it features the load weigh system. The Load Weigh System is a complement to the helicopter external load lifting system. Its purpose is to display the weight of the load carried on the cargo hook. It includes the pin load cell assembly integrated into the cargo hook (ref. Figure 3.1.3), a load weigh indicator, and an interconnecting wire harness.

Kit P/N 200-438-01 also includes the load weigh system and is the same as P/N 200-438-00 except it includes several load weigh system parts that are specific to the S-70M model.

An external load is attached to the cargo hook by sliding a load ring over the open load beam and pushing it up to latch the cargo hook. The external load can be released from the cargo hook by three different methods. Normal (or primary) release is achieved by pilot actuation of the existing factory installed cargo release switch on the cyclic. When the button is pressed, it energizes a solenoid in the cargo hook via the primary electrical release connector (ref. Figure 3.1.1) and the solenoid opens the internal mechanism. For emergency (or backup) means of release, the cargo hook uses the helicopter's existing emergency release switch on the collective. When this button is pressed a second solenoid in the cargo hook is energized via the backup electrical release connector (ref. Figure 3.1.2) and this solenoid acts independently on the internal mechanism. The load can also be released by ground crew using a lever (ref. Figure 3.1.2) located on the side of the cargo hook.

	Owner's Manual Cargo Hook Kit	Document Number 120-224-00	Revision 5
		Date 07/01/24	Page 6 of 39

Figure 3.1.1 Overview of Cargo Hook, Left Side

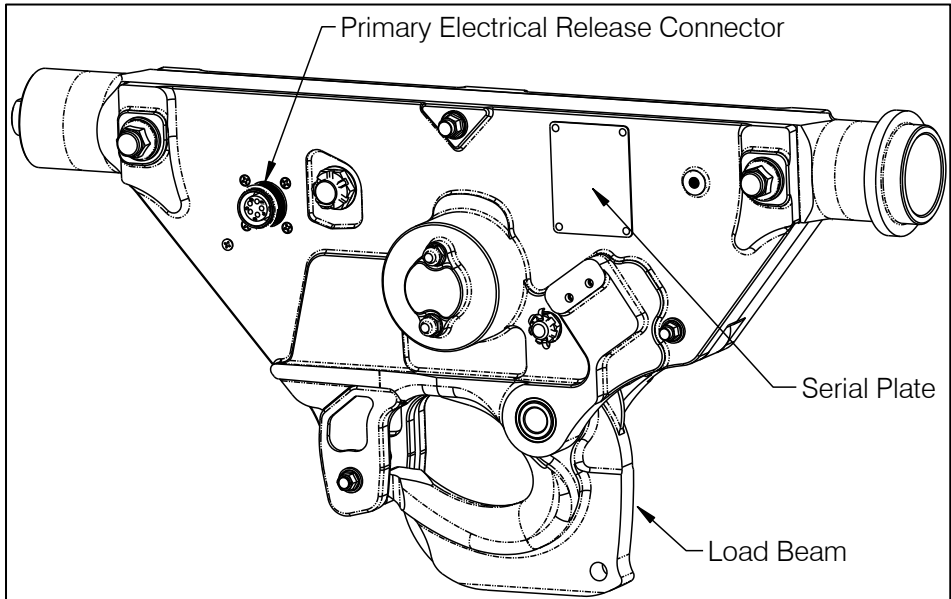
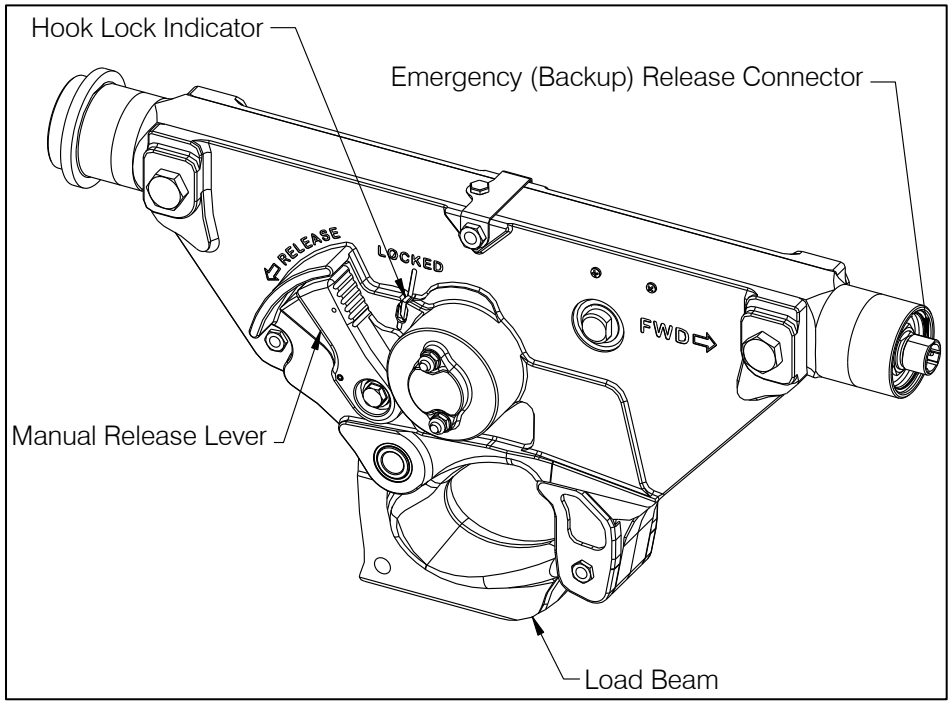



Figure 3.1.2 Overview of Cargo Hook, Right Side



Cargo hook P/N 528-043-10 is included with kit P/N 200-438-00 and has an integrated pin-style load cell, the load cell is calibrated individually in each cargo hook at the factory.

	Owner's Manual Cargo Hook Kit	Document Number 120-224-00	Revision 5
		Date 07/01/24	Page 7 of 39

To maximize accuracy of the load weigh system a custom shackle (P/N 232-814-00) should be used. This shackle features a roller with a roller bearing to provide a design which more readily moves to the ideal position on the load beam for load cell accuracy.

Figure 3.1.3 Cargo Hook with Pin Load Cell

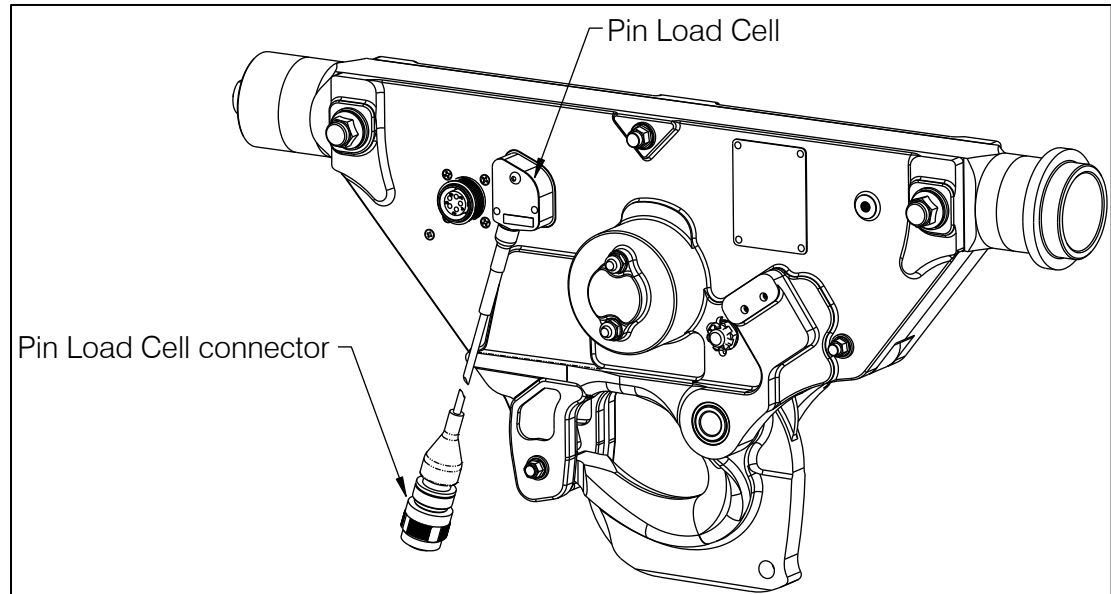

The load weigh indicator included with the Load Weigh System is Onboard Systems next generation indicator, the C-40 model. The C-40 Indicator makes several improvements over its predecessor (the C-39 model) while preserving classical features. The C-40 Indicator offers these improvements:

- Full color display
- Load measurement displayed in full, not X 10 (C-39 is X 10)
- Addition of Analog Bar and Maximum Load features
- Simplified user interface
- Addition of Cargo Hook hour meter
- Selectable backlight control voltage, 5 or 28 VDC
- Improved moisture resistance
- Expanded signal input range
- Field-upgradable firmware

Refer to the C-40 Owner's Manual 120-152-00 for additional information and detailed operating instructions for the C-40 Indicator.

	Owner's Manual Cargo Hook Kit	Document Number 120-224-00	Revision 5
		Date 07/01/24	Page 8 of 39

3.2 Surefire Release

The cargo hook includes a Surefire Release within its primary quick release sub-system (PQRS). Surefire Release is a short time delay circuit built into the cargo hook's electrical release system. This feature is a safety enhancement to protect against inadvertent load release due to accidental contact with the release switch or mistaken actuation of the cargo hook switch. The time delay feature requires that the release switch be depressed and **held** for more than a 1/2 second to open the cargo hook. Surefire makes the electrical release a more deliberate pilot command. If the cargo hook must be released immediately, use the backup release. The backup release system does not include Surefire and has no time delay.

NOTICE

Cargo hook includes an electronic delay of approximately ½ second in its primary release system. It is necessary to press and hold the cargo hook release button to release the load.

CAUTION

If a Surefire-equipped cargo hook must be released immediately without any delay (such as the case of engine failure or snagged load), use the backup release system.

In addition to the delay feature the circuit includes on-off cycling to limit the duty-cycle on the cargo hook solenoid. If the release switch is held down, the solenoid will cycle on and off repeatedly in a "machine gun" fashion.

	Owner's Manual Cargo Hook Kit	Document Number 120-224-00	Revision 5
		Date 07/01/24	Page 9 of 39

3.3 Bill of Materials

The following items are included with the Cargo Hook Kit P/Ns 200-437-00, 200-438-00 and 200-438-01. If shortages are found contact the company from whom the system was purchased.

Table 3.3.1 Cargo Hook Kit Bill of Materials

Part No.	Description	200-437-00	200-438-00	200-438-01
210-293-01	C-40 Indicator**	-	1	1
215-010-00	Elect. Weighing System Placard	-	1	1
215-169-00	INOP Placard	1	1	1
215-343-00	Cockpit Decal	1	1	1
215-394-00	Circuit Breaker Label	1	1	1
232-780-00	Secondary Relay Module	1	1	1
235-280-00	Doubler	-	1	-
235-320-00	Doubler, S-70M	-	-	1
235-321-00	Connector Bracket	-	-	1
270-233-00	Primary Release Harness	1	1	1
270-234-00	Load Weigh Internal Harness	-	1	1
270-245-00	Jumper, S-70M	1	-	1
270-281-00	Jumper	1	1	-
528-043-00	Cargo Hook Assembly	1	-	-
528-043-10	Cargo Hook Assembly w/ Pin Load Cell	-	1	1
410-199-00	Shield Termination	-	1	1
410-296-00	Ring Terminal	1	1	1
410-488-00	Dust Cap Receptacle	-	-	1
410-489-00	Dust Cap	-	-	1
410-918-00	Connector	-	1	1
440-018-00	Circuit Breaker	2	2	2
450-005-00	Heat Shrink	-	2"	2"
510-095-00	Washer	2	2	2
510-102-00	Nut	2	2	2
510-391-00	Screw	2	2	2
510-481-00	Screw	-	-	4
511-203-00	Perimeter Nut Plate	-	-	1
511-210-00	Rivet	-	14	20
511-211-00	Screw, 6-32	-	4	4
512-024-00	Cushioned Loop Clamp	8	8	8
120-152-00	Owner's Manual, C-40 Indicator*	-	1	1
120-224-00	Owner's Manual*	1	1	1
121-066-00	RFMS*	1	1	1
122-032-00	CMM, Cargo Hook*	1	1	1
123-046-00	ICA*	1	1	1

*Documentation must be downloaded from www.onboardsystems.com

**C-40 Indicator P/N 210-293-01 replaces P/N 210-293-00 in new productions kits as of November 2023, these are interchangeable with the exception of software compatibility. Refer to C-40 Owner's Manual 120-152-00 for specific software versions.

	Owner's Manual Cargo Hook Kit	Document Number 120-224-00	Revision 5
		Date 07/01/24	Page 10 of 39

Material/items required for the installation that are not included with the cargo hook kits are listed in Table 3.3.2.

Table 3.3.2 Installer Supplied Material

Description
MIL-DTL-5541 Class 1A Coating or MIL-PRF-23377 Epoxy Primer
P/S-870 Sealant
MS3320-1 Circuit Breaker

3.4 Specifications

Table 3.4.1 Cargo Hook Specifications

Design load rating*	9,000 lb. (4,082 kg)
Design ultimate strength	33,750 lb. (15,309 kg)
Electrical release capacity	22,500 lb. (10,206 kg)
Electrical requirements	12.6 amps at 28 VDC
Minimum release load	0 pounds
Mating primary electrical release connector	MS3459W14S-5P
Mating backup electrical release connector	D38999/26WB2SN



**Load ratings given are specific to the equipment described only. Loading limits for the helicopter still apply. Consult the flight manual issued by the TC holder and the RFMS provided with the cargo hook kit for limits.*

Table 3.4.2 C-40 Indicator Pin-out

Pin	Function
A	+28 VDC
B	- Load Cell Signal Return
C	+ Load Cell Signal
D	+ Load Cell Excitation
E	- Load Cell Excitation Return
F	Analog Out Common
G	+ Analog Out
H	Hook Open (In)
J	RS232 TX
K	TEDS Data (In)
L	Shield
M	Backlight Common
N	Backlight Signal 0-28 VDC (In)
P	Aircraft Ground Bonding/EMI Ground
R	Load on Hook (Out)

	Owner's Manual Cargo Hook Kit	Document Number 120-224-00	Revision 5
		Date 07/01/24	Page 11 of 39

4.0 Installation

These procedures are provided for the benefit of experienced aircraft maintenance facilities capable of carrying out the procedures. They must not be attempted by those lacking the necessary expertise.

4.1 Electrical Wiring Installation

This section provides instructions for installation of new fixed provisions electrical wiring and modifications to existing wiring for operation of the cargo hook. Also included in this section are instructions for installation of the optional load weigh system (included with kit P/Ns 200-438-00 and 200-438-01).

NOTICE

The backup electrical release system draws a 12.6-amp intermittent load and must be installed on the DC essential bus. It is the responsibility of the installer to ensure that there is adequate capacity for this load.

In preparation for routing the electrical wires from the cargo hook to the circuit breaker panels remove the floor panels to access forward and to the left of the cargo hook well.

Route all wires using the following general guidance.

- Pick up existing wire runs by opening existing loop clamps, nylon ties alone may not be used for primary support.
- New wire runs should be supported with MS21919 loop clamps.
- The distance between supports should not exceed 21".
- The minimum radius of bends in wire groups or bundles must not be less than 10 times the outside diameter of the largest wire or cable.
- Inspect and verify that the wire harness may not be manually deflected into a structure with a bend radius less than .125".

4.1.1 Primary Electrical Release

The cargo hook's primary electrical release system uses the aircraft's existing internal electrical wiring except for the installation of a wire to bypass the anti-cycle relay and replacing the existing 10-amp breaker with a supplied 15-amp circuit breaker. The schematic below shows the complete electrical system including fixed provisions wiring (in dashed lines) and the wiring provided with the cargo hook kit.

	Owner's Manual Cargo Hook Kit	Document Number 120-224-00	Revision 5
		Date 07/01/24	Page 12 of 39

Figure 4.1.1 Primary Electrical Release Schematic



Remove the 10-amp circuit breaker (labeled Cargo Hook Pwr) at the No. 2 DC primary bus and replace with the supplied 15-amp circuit breaker (P/N 440-018-00).

Bypass the anti-cycle relay K23 in the right relay panel per the following instructions.

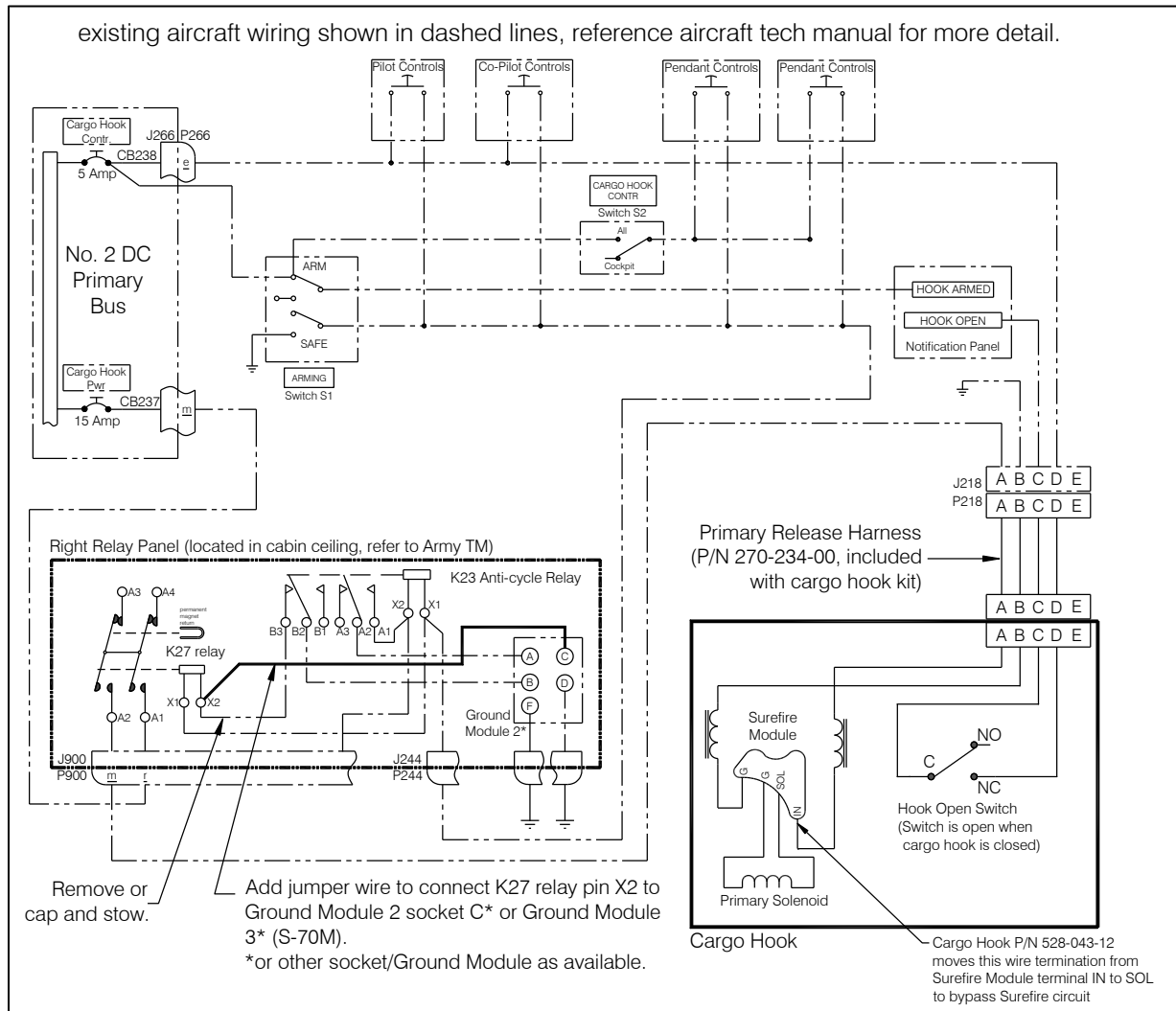
1. Disconnect (un-solder or remove ring terminal) the wire from terminal X2 of the K27 relay (this wire is routed to terminal B3 of the K23 anti-cycle relay). Cap and stow this wire or remove it completely.
2. Two Jumpers are provided with the kit: use P/N 270-281-00 for all models except S-70M, for the S-70M use P/N 270-245-00. Insert the end of the supplied Jumper terminated with the contact into ground module 2 socket C or other socket/ground module as available in the right relay panel.

	Owner's Manual Cargo Hook Kit	Document Number 120-224-00	Revision 5
		Date 07/01/24	Page 13 of 39

- Route the other end of the Jumper to terminal X2 of the K27 relay and cut to length as necessary.

For Jumper P/N 270-281-00: strip and prep for soldering and then solder to X2 and shrink a length of heat shrink (not provided) over the solder joint.

If installing Jumper P/N 270-245-00: strip the wire and crimp on the ring terminal (P/N 410-240-00) supplied with the Jumper and attach to the K27 relay.

4.1.2 Backup Electrical Release Wiring

The cargo hook's backup electrical release system uses the aircraft's existing electrical circuit that was used to "fire" the cartridge actuated device (CAD, also referred to as a squib) of the legacy Breeze/Aeroquip cargo hook. This squib circuit is re-purposed to energize a relay with some modifications required to disable components of the circuit that are not used with the new cargo hook. In addition, a new circuit breaker, wire harness, and a connector are to be added.

A schematic for the backup electrical release system is shown in Figure 4.1.3. Modify existing fixed provisions and install the new components and wiring per the following.

- Locate the existing cargo hook emergency release system resistor R4 and terminal block 1 in the upper console (see below).

	Owner's Manual Cargo Hook Kit	Document Number 120-224-00	Revision 5
		Date 07/01/24	Page 14 of 39

Figure 4.1.2 R4 Resistor



2. Disconnect the R4 resistor by verifying the wires from it are terminated at terminal block 1, terminals 4 and 5 then removing the wires.
3. Optionally remove the R4 resistor from the aircraft or cap and stow its wires.
4. At terminal block 1 move the wire from terminal 4 to 5 (see Figure 4.1.3).
5. The squib test circuit switch (DS1) in the upper console is not used. Optionally disconnect the wire from pin 3 (see Figure 4.1.3). If disconnected, cap and stow the disconnected wire.

Figure 4.1.3 Backup (Emergency) Cargo Hook Release Electrical Schematic (H-60 series shown)

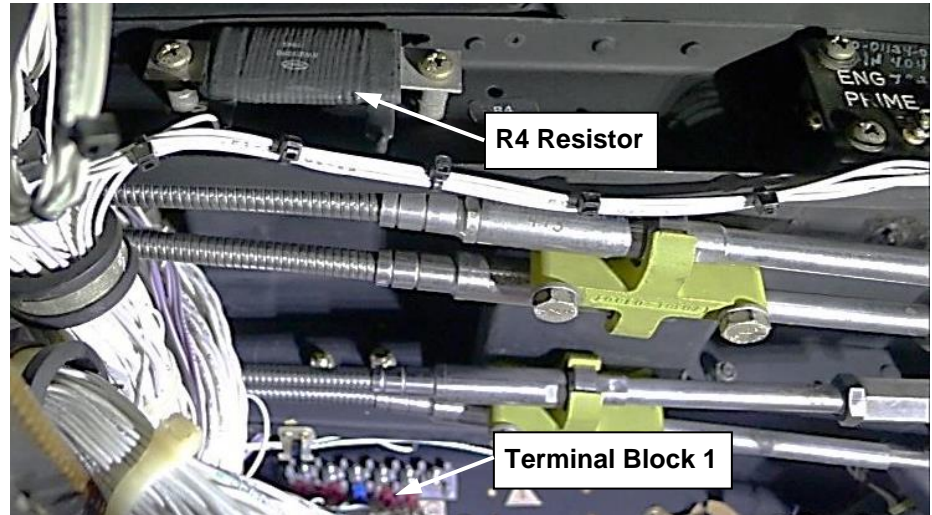
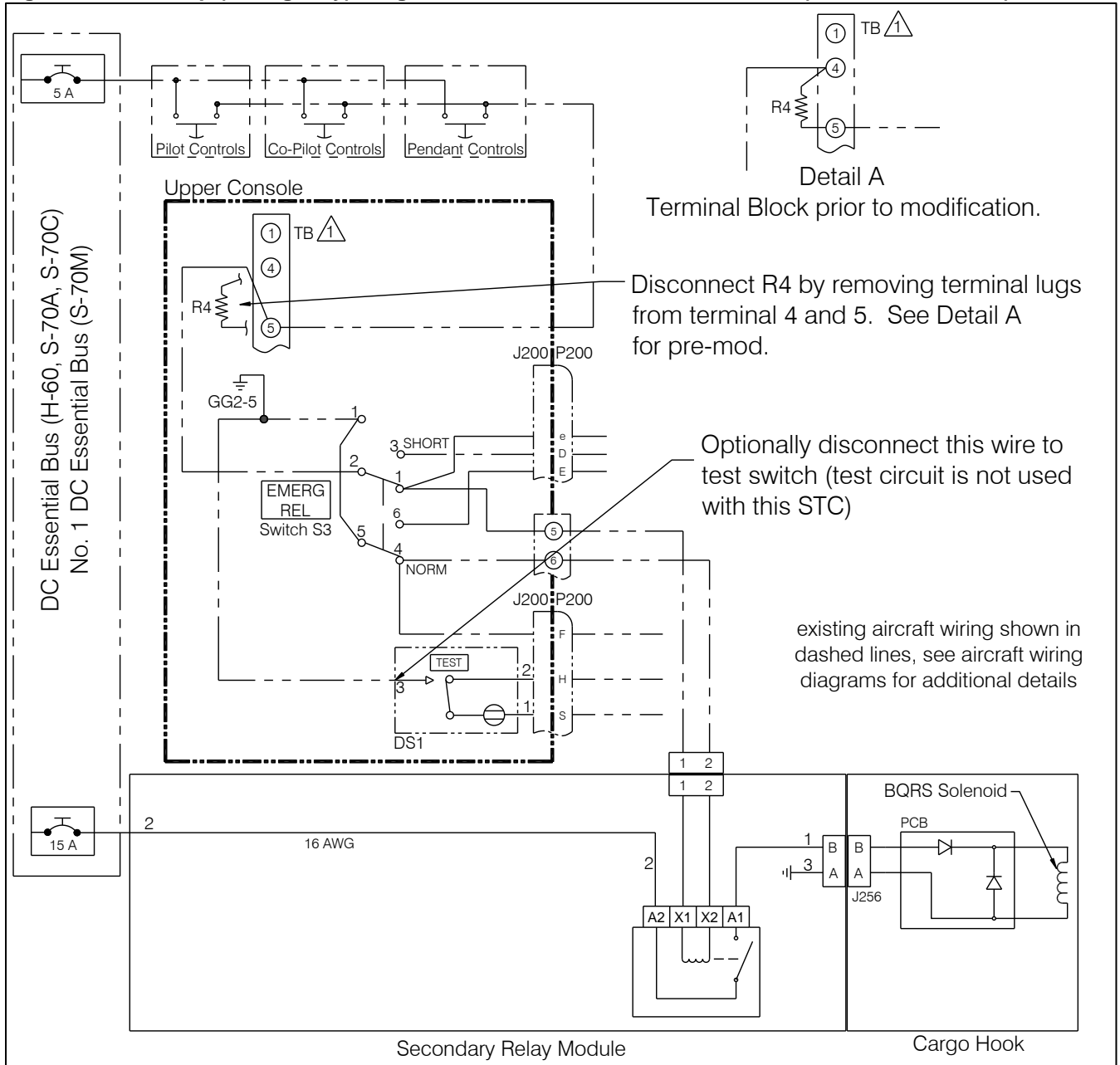

	Owner's Manual Cargo Hook Kit	Document Number 120-224-00	Revision 5
		Date 07/01/24	Page 16 of 39

The existing connector to the cargo hook to energize the squib is to be connected to a connector on the supplied Secondary Relay Module (P/N 232-780-00). The Secondary Relay Module includes a bracket with the relay, connector, and wiring pre-installed on it. This assembly is mounted under the floor just forward of the cargo hook. Install it per the following instructions.

6. Locate the existing hole in the stringer (ref. Figure 4.1.5), to the left of centerline of the aircraft. On the H-60 series and S-70A and S-70C this hole is approximately 3 1/2" forward of the forward supporting frame at STA 343 for the cargo hook. On the S-70M, it is several inches further forward (see below).

Figure 4.1.4 Existing Hole for Secondary Relay Module – S-70M

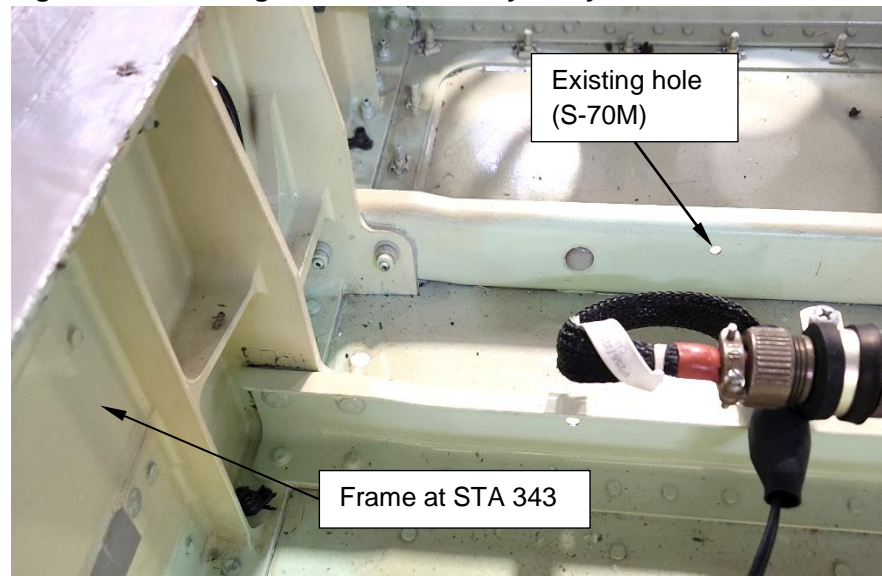

7. Position the Secondary Relay Module bracket on the inboard side of the stringer with the wires towards the outside of the aircraft and its aft mounting hole at the existing hole. On the S-70M, position the bracket's forward mounting hole at the existing hole.
8. Match drill a Ø0.201" hole in the stringer at the second bracket hole location.

	Owner's Manual Cargo Hook Kit	Document Number 120-224-00	Revision 5
		Date 07/01/24	Page 17 of 39

Figure 4.1.5 Secondary Relay Module Installation



- Secure the bracket at the forward hole with one of the supplied screws (P/N 510-391-00), washers (P/N 510-095-00) and nuts (P/N 510-102-00). The ring terminal of wire no. 3 will be secured at the aft hole in the following steps.

For the following steps refer to Figure 4.1.6

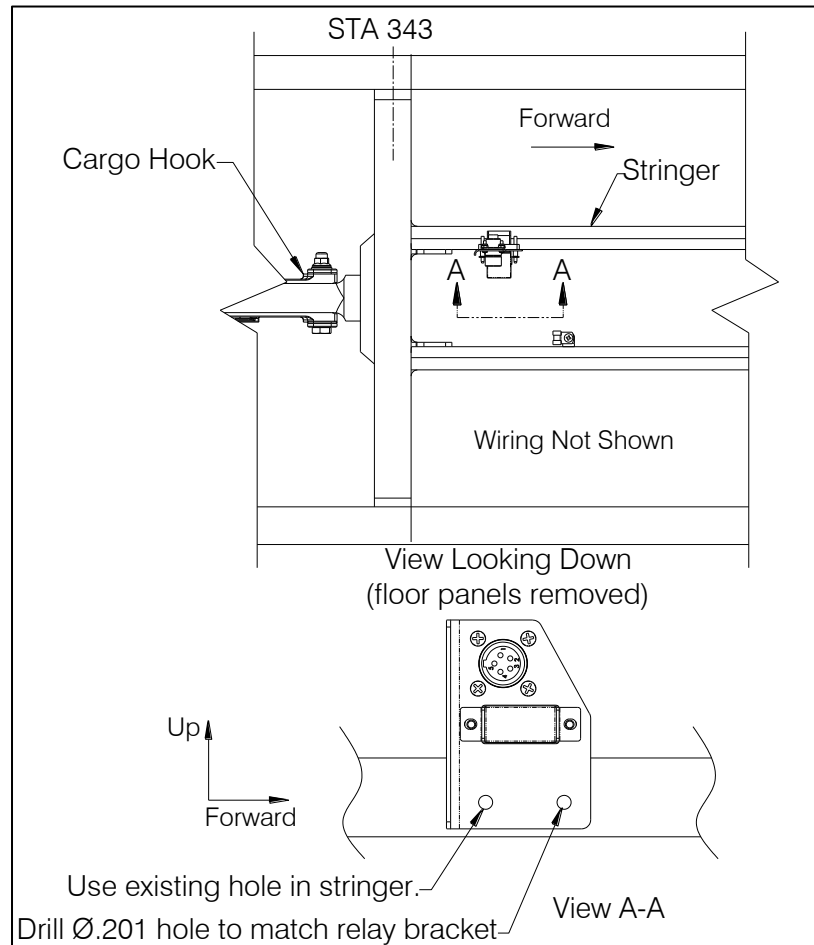
- Connect the squib harness connector (P256) to the connector on the relay module, (when DC power is on, the squib electrical system will energize the relay coil). The connector on the short harness from the relay module will be connected to the cargo hook after it is installed.
- Route wire no. 3 from the connector to the aft mounting hole for the relay bracket.

	Owner's Manual Cargo Hook Kit	Document Number 120-224-00	Revision 5
		Date 07/01/24	Page 18 of 39

12. Remove the paint in an approximate ¼" diameter around the aft mounting hole on the **outboard** side of the frame for grounding purposes and attach the ring terminal of wire no. 3 with the supplied screw (P/N 510-391-00), washer (P/N 510-095-00) and nut (P/N 510-102-00).

13. Route wire no.2 from the relay module to the right and then forward along the route of the CAD release wiring. Route this wire to the DC essential bus with existing wire bundles.

Figure 4.1.6 Wire Routing for Backup Release

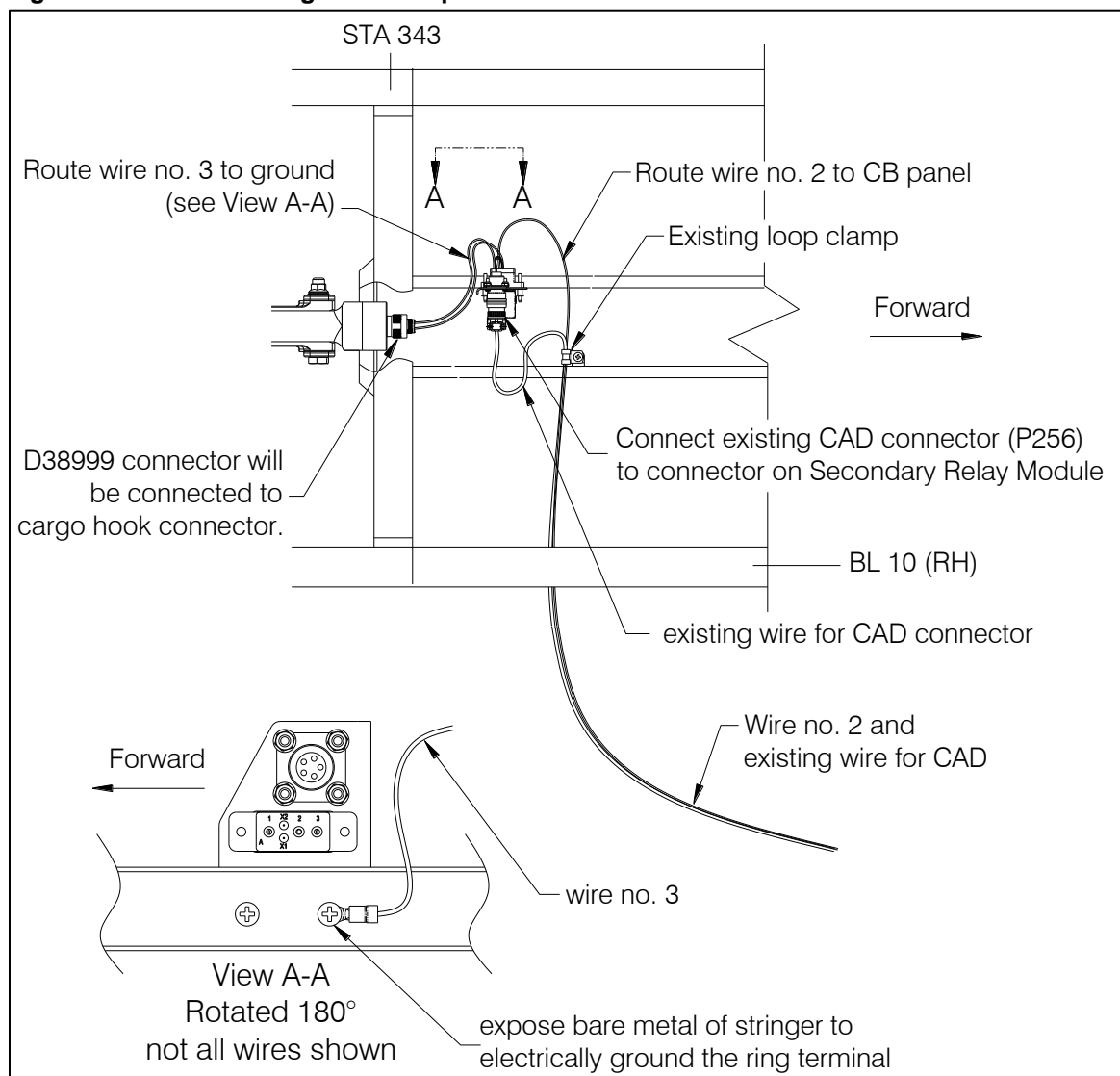

14. Install the supplied 15-amp circuit breaker (P/N 440-018-00) in an available location on the DC essential bus.

	Owner's Manual Cargo Hook Kit	Document Number 120-224-00	Revision 5
		Date 07/01/24	Page 19 of 39

15. Route wire no. 2 to the circuit breaker, replacing the existing loop clamps with the larger supplied cushioned loop clamps (P/N 512-024-00) as needed, and cut it to length as necessary and terminate it at the circuit breaker using the supplied ring terminal (P/N 410-296-00).

4.2 Load Weigh System Installation

Install a Doubler (for the load cell connector), the Load Indicator, and internal load weigh system wiring harness per the following instructions.

4.2.1 Doubler Installation

The load cell connector is mounted in the beam forming the left side of the hook well, requiring a hole to be created. The hole is to be reinforced with a Doubler.

Doubler P/N 235-280-00 is provided under kit P/N 200-438-00 which is for all models except the S-70M. For the S-70M, kit P/N 200-438-01 includes Doubler P/N 235-320-00.



Refer to Figure 4.2.1 for installation of Doubler P/N 235-280-00 and Figure 4.2.2 for installation of Doubler P/N 235-320-00 on the S-70M model.

Create the hole and install the Doubler on the outboard side of the beam per the following instructions.

1. Remove the LH rear cabin floor panel to gain access to the outboard side of the beam at left BL 10 which forms part of the hook well.
2. If present, disconnect electrical connectors for the hook well lights and secure out of the way.
3. Visually inspect the frame at BL 10 using 10X magnification in installation area. Verify no cracks or damage is present.
4. **On the S-70M only**, remove the lower two existing rivets that secure the existing connector bracket to the frame (as shown in Figure 4.2.2).
5. Verify fit of Doubler at the location shown in Figure 4.2.1 (all models except S-70M) or Figure 4.2.2 (S-70M) and verify its mounting holes have a minimum of 2D edge distance with existing holes.
6. The S-70M model has space for an optional supplied Connector Bracket (P/N 235-321-00) on the inside of the hook well for a dust cap receptacle. It

	Owner's Manual Cargo Hook Kit	Document Number 120-224-00	Revision 5
		Date 07/01/24	Page 20 of 39

picks up the two forward holes in the lower row of holes in the Doubler (P/N 235-320-00) as shown in Figure 4.2.2.

7. Transfer the Doubler rivet hole pattern, electrical connector hole location, and Connector Bracket (if installed) holes to the aircraft frame.
8. Drill out the pilot holes in the Doubler and Connector Bracket (if installed) to 0.159" (#21 drill bit).
9. Create a 0.813" hole in the beam for the connector and drill the beam for the rivets using the #21 drill.
10. Deburr all holes and protect all bare metal surfaces with MIL-DTL-5541 Class 1A chemical conversion coating or MIL-PRF-23377 epoxy primer.
11. Install the Doubler and supplied rivets (P/N 511-210-00, MS20470AD5-4*) wet with P/S 870 (or equivalent) corrosion inhibiting sealant. *as necessary use longer

	Owner's Manual Cargo Hook Kit	Document Number 120-224-00	Revision 5
		Date 07/01/24	Page 21 of 39

Figure 4.2.1 Doubler Installation (all models except S-70M)



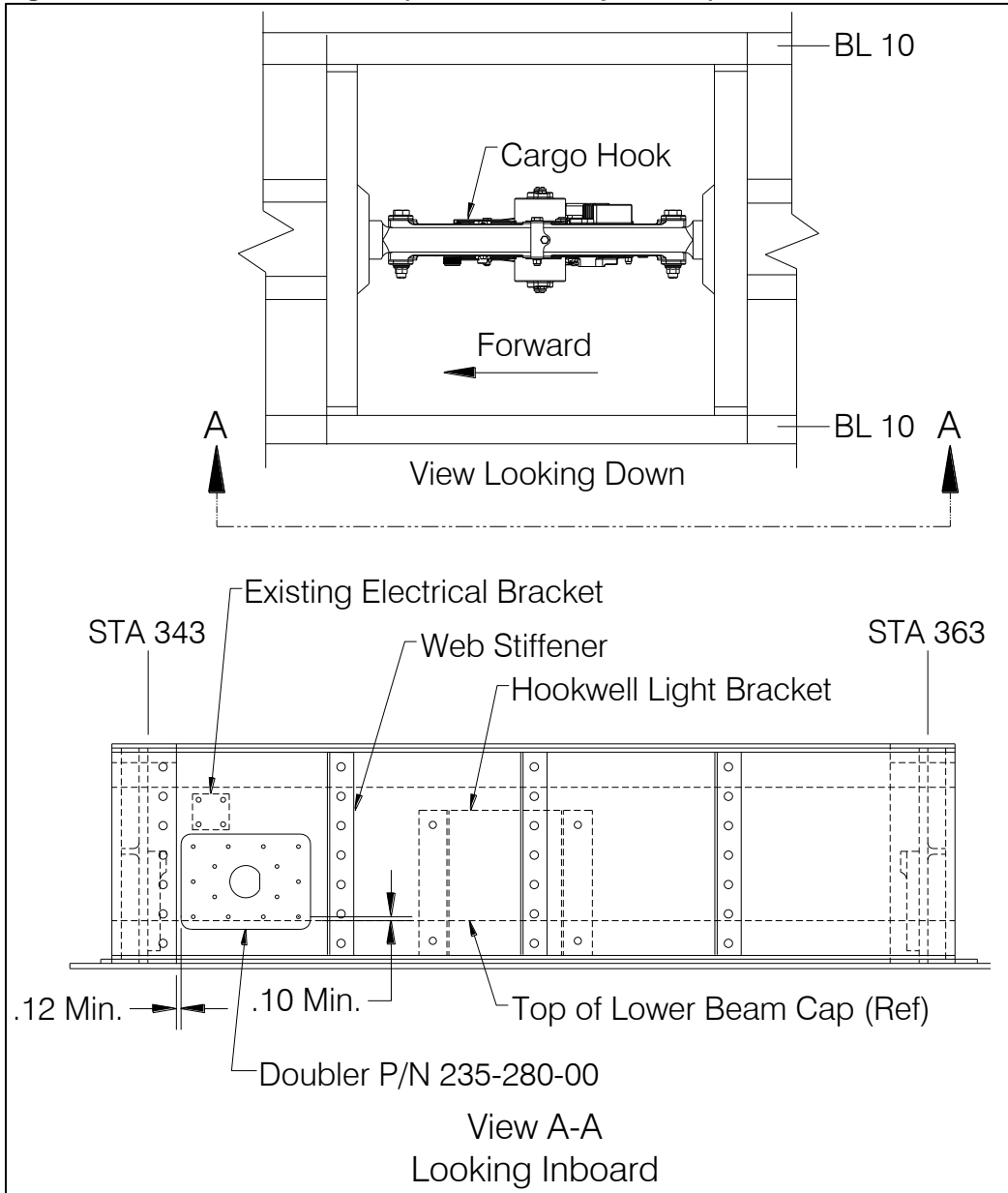

	Owner's Manual Cargo Hook Kit	Document Number 120-224-00	Revision 5
		Date 07/01/24	Page 22 of 39

Figure 4.2.2 S-70M Doubler Installation

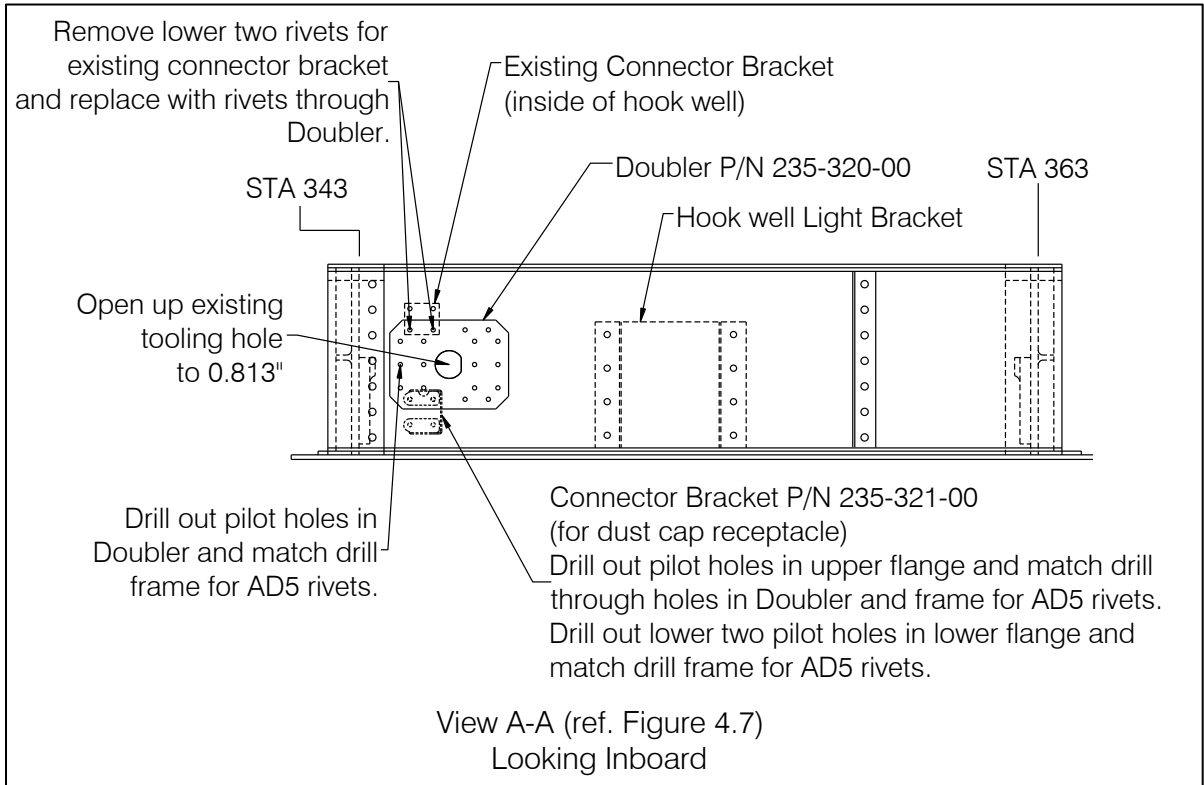

	Owner's Manual Cargo Hook Kit	Document Number 120-224-00	Revision 5
		Date 07/01/24	Page 23 of 39

4.2.2 Load Indicator Installation

The C-40 Indicator location is optional. It is designed to mount within a standard 2 ¼" instrument panel hole or can be mounted within a support bracket (not included in the kit) using the four supplied 6-32 screws (P/N 511-211-00) or equivalent screw if mounting location requires a longer or shorter screw. The Indicator features 6-32 threaded inserts on the front side and the back side for versatile mounting. Listed below are some considerations for locating the C-40 Indicator.

- Convenient for the pilot to check during external load operations.
- Avoid a location which may result in objectionable glare/reflection.
- The wire harness can be routed and connected to the back of it.
- Accessibility of the USB connector on the back side for future firmware upgrades.

4.2.3 Load Weigh Harness Installation

Install the internal load weigh harness (P/N 270-234-00) per the following instructions. Refer to Figure 4.2.4 for schematic.

1. Connect the "C-40" connector of the load weigh harness to the back of the C-40 Indicator.
2. From the C-40 Indicator, route the wire labeled "POWER" to the No. 1 or No. 2 DC primary bus and cut to length as necessary.
3. Install one MS3320-1 circuit breaker (not supplied) and connect the POWER wire to it.
4. Route the BACKLIGHT SIG wire of the harness to the aircraft's instrument lighting circuit and terminate it there.
5. Route the A/C GROUND and BACKLIGHT COM wires to an aircraft ground point and terminate them per AC43.13.

NOTICE

The Indicator functions normally without its Backlight Control Voltage wired (through the BACKLIGHT SIG and BACKLIGHT COM wires), but will just not dim with other instruments. Full brightness of the Indicator is overridden by the aircraft dimming control voltage (if connected).

	Owner's Manual Cargo Hook Kit	Document Number 120-224-00	Revision 5
		Date 07/01/24	Page 24 of 39

6. Route the LOAD Cell wire aft with existing wire bundles to the outboard side of the beam forming the left side of the hook well.
7. Slide heat shrink (P/N 450-005-00) and shield termination (P/N 410-199-00) over the harness and prep the "LOAD CELL" 6 conductor wire end per Figure 4.2.3. Terminate the wires to the connector pins per the schematic of Figure 4.2.4. The WH/RED wire of the 6-conductor wire is not used. The WH/BLK wire is for possible future implementation of TEDS feature into the C-40 Indicator.

Figure 4.2.3 Harness Prep

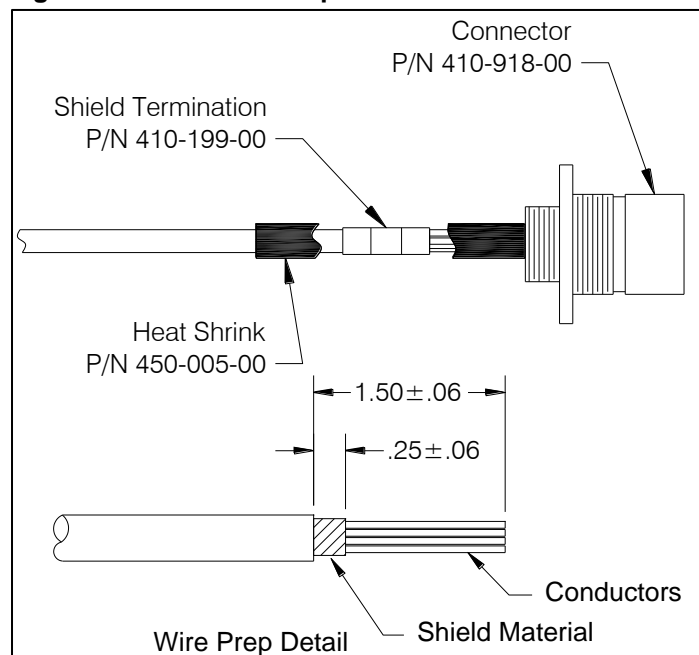

8. Secure the connector (with the nut provided with it) within the 0.813" diameter hole created per section 4.2.1.

4.2.4 Load Weight System Dust Cap Receptacle Installation

If the optional Connector Bracket was installed (on the S-70M model), install the Dust Cap Receptacle (P/N 410-488-00) on it with four screws (P/N 510-481-00) and the Perimeter Nut Plate (P/N 511-203-00). Secure the lanyard of the Dust Cap (P/N 410-489-00) under the head of one of the screws.



	Owner's Manual Cargo Hook Kit	Document Number 120-224-00	Revision 5
		Date 07/01/24	Page 25 of 39

Figure 4.2.4 Load Weigh System Schematic

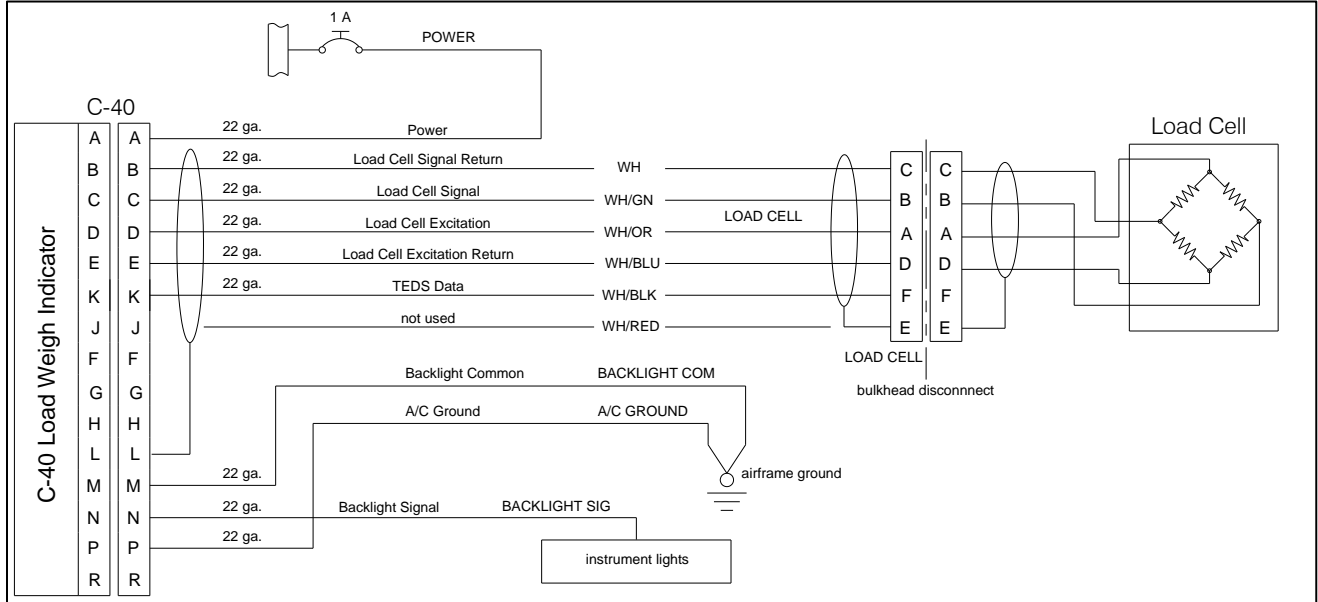

	Owner's Manual Cargo Hook Kit	Document Number 120-224-00	Revision 5
		Date 07/01/24	Page 26 of 39

4.3 Cargo Hook Installation

1. Remove the existing cargo hook by removing screws, washers, and nuts securing the clamps at the forward and aft trunnion cradles and disconnecting the electrical release harness connector (J218) at the forward frame and the CAD's electrical connector (J256) at the forward trunnion. Lift the old cargo hook out of the cradles to remove it.
2. If a ground strap was present on the cargo hook that was removed, remove it and re-install it to the tapped hole on the left side of the cargo hook (ref. Figure 4.3.1). Before installing, remove the anodize from the raised surface around the tapped hole and treat with a conductive chemical conversion coating such as Alodine. The Cargo Hook features a grounding bracket which serves to electrically ground the three parts which make up the cargo hook case.

Figure 4.3.1 Ground Strap Attachment

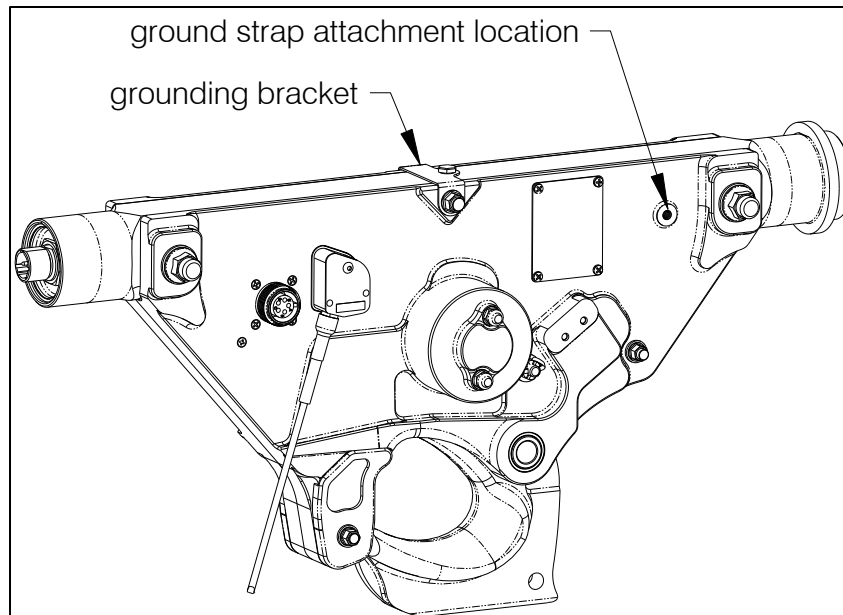

3. Orient cargo hook (P/N 528-043-00 or P/N 528-043-10) with the load beam pointing forward (the side of the cargo hook also has "FWD" engraved and an arrow.)
4. Angle the new cargo hook with its forward end up and within the forward cradle on the forward wall of the hook well. Move the aft end of the cargo hook to the side and then up and around and into the aft cradle. The cargo hook should fit concentrically within the cradles and freely pivot from side to side.
5. Re-install the clamps with the existing screws, washers, and nuts. If the ground strap is present, re-attach it at same location from which it was removed. Tighten nuts to 43-47 in-lbs. and verify that the cargo hook pivots side to side without binding.



	Owner's Manual Cargo Hook Kit	Document Number 120-224-00	Revision 5
		Date 07/01/24	Page 27 of 39

Figure 4.3.2 Cargo Hook Installation

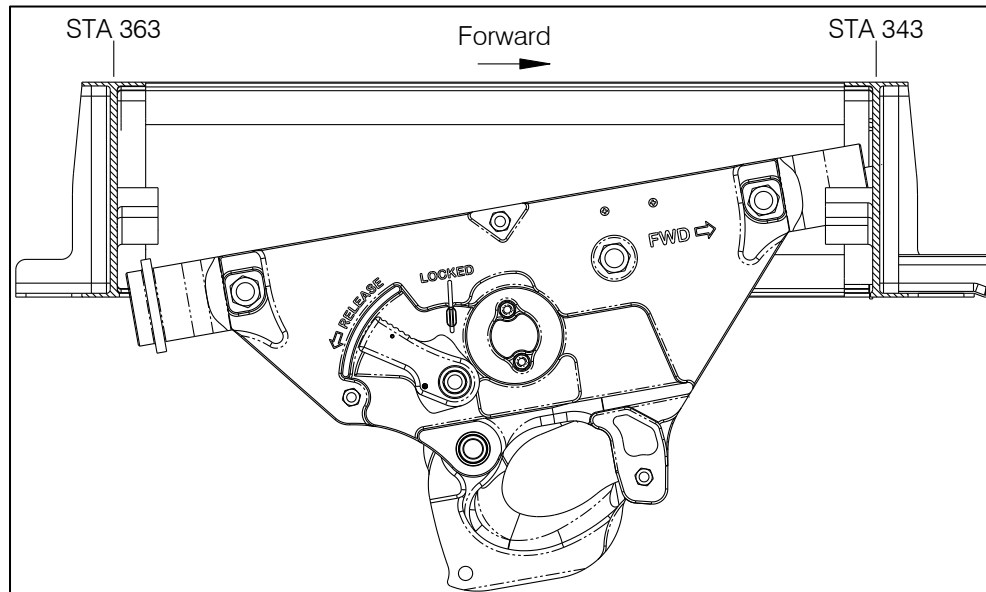

6. Connect either end of the external electrical harness (P/N 270-233-00) to the cargo hook connector and the other end to the existing connector J218 in the forward frame of the hook well.
7. Connect the connector from the Secondary Relay Module to the cargo hook connector mounted in the forward end of the trunnion.
8. If cargo hook P/N 528-043-10 (with Pin Load Cell) is installed, connect the Pin Load Cell connector to the connector installed at the Doubler.

	Owner's Manual Cargo Hook Kit	Document Number 120-224-00	Revision 5
		Date 07/01/24	Page 28 of 39

4.4 Placards

Following table summarizes the placards to be installed (depending on kit configuration).

Table 4.4.1 Placards

Placard Description (Placard P/N)	Location
INOP Placard (P/N 215-169-00)	Install under the EMERG REL TEST button/light on the upper console.
CARGO HOOK BREAKER DECAL (P/N 215-394-00)	Mount "CARGO HOOK" and "EMER PWR" adjacent to the 15-amp circuit breaker added to the DC essential bus panel and "EMER CONTR" adjacent to the existing 5-amp cargo hook circuit breaker on the DC essential bus panel.
ELECTRONIC WEIGHING SYSTEM (P/N 215-010-00)	Install adjacent to the load weigh 1-amp circuit breaker in clear view of the pilot (if load weigh system is installed).
CARGO RELEASE HOLD FOR >1 SECOND (P/N 215-343-00)	Install near the primary CARGO REL switch on the cyclic in clear view of the pilot.

	Owner's Manual Cargo Hook Kit	Document Number 120-224-00	Revision 5
		Date 07/01/24	Page 29 of 39

4.5 Installation Check-out

After installation of the Cargo Hook Kit, perform the following functional checks.

1. Rotate the cargo hook laterally to ensure that the electrical harnesses (electrical release harness and load weigh harness (if installed)) have enough slack to allow full swing of the cargo hook without being pulled tight. The harnesses must not interfere or prevent the cargo hook from swinging throughout its full range of motion.
2. Rotate the cargo hook laterally until it engages the stowage latch. Ensure the cargo hook load beam engages the latch and is secure. Release the cargo hook from the latch and ensure the cargo hook swings down freely.
3. Turn on aircraft electrical power, close the cargo hook primary release circuit breaker and provide power to the system. The cargo hook primary release is equipped with Surefire electrical release. With no load on the cargo hook perform the following.
 - Very briefly (less than ½ second) press the Cargo Release switch on the pilot's cyclic, the cargo hook should not actuate and the load beam should remain closed.
 - Press and hold the Cargo Release switch for 2 – 5 seconds, the load beam should fall to the open position and the cargo hook's solenoid should continue to cycle repeatedly.
 - Repeat these steps for the co-pilot's cyclic Cargo Release switch.
 - Push up on the load beam and verify that it latches. Verify that the hook lock indicator groove is aligned with the engraved lines on the side plate.

Figure 4.5.1 Hook Locked Indication

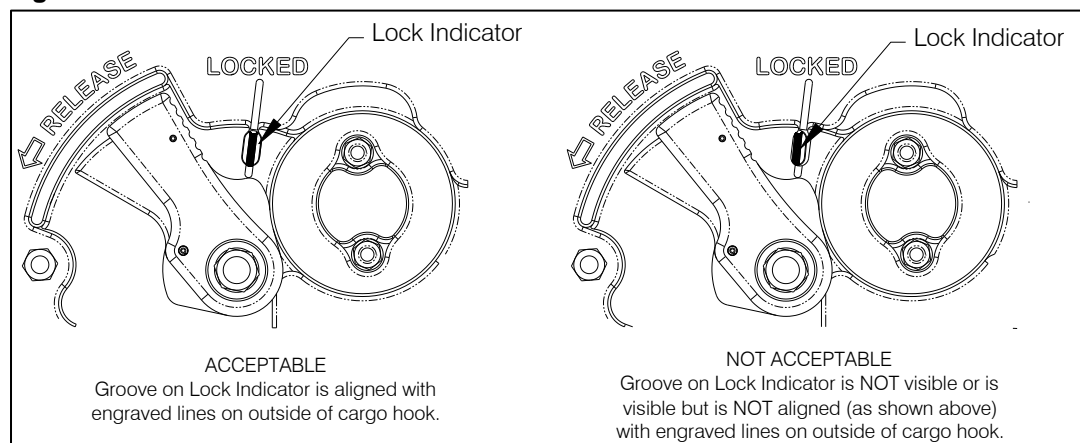

	Owner's Manual Cargo Hook Kit	Document Number 120-224-00	Revision 5
		Date 07/01/24	Page 30 of 39

4. Close the cargo hook backup release EMER circuit breakers (if open) and provide power to the backup (emergency) release system. With no load on the cargo hook perform the following.
 - Depress the Emergency Release switch on the collective; the cargo hook load beam should open immediately. Push up on the load beam and verify that it latches. Verify that the hook lock indicator groove is aligned with the engraved lines on the side plate.
 - Repeat this step for the co-pilot's collective Emergency Release switch.
5. Verify operation of the ground crew release: squeeze the gold inner part of the manual release lever into the outer part and rotate together in the counterclockwise direction. The lever should rotate smoothly and the cargo hook load beam should open. Release the lever and the inner part should extend back out and the manual release lever assembly should return to its starting position.
6. Verify the resistance between airframe side attachment of the ground strap and the grounding bracket on the Cargo Hook (ref. Figure 4.3.1). The resistance must be less than 10 milli-ohms.

If the Load Weigh System was installed, perform steps 7 through 9.

7. Push in the 1-amp circuit breaker to power on the Load Weigh System. On startup the C-40 Indicator will display an information screen while performing a brief self-diagnostic routine and then display the load screen. Set the Installation Zero for the installation per the instructions contained in the C-40 Indicator's Owner's Manual 120-152-00.
8. In the Settings menu select desired units (lb or kg), brightness of the display, maximum load, backlight voltage and other settings as preferred (refer to the C-40 Indicator Owner's Manual 120-152-00 for detailed instructions).

NOTICE

One setting that must be set to function properly is the backlight voltage. If the wire for the backlight was connected the backlight voltage must be set to the aircraft circuit voltage (5 VDC or 28 VDC). Setting to the incorrect voltage will not damage the unit; it will either be brighter or dimmer than it should be.

	Owner's Manual Cargo Hook Kit	Document Number 120-224-00	Revision 5
		Date 07/01/24	Page 31 of 39

9. Enter the Cal Code located on the Pin Load Cell (on the Cargo Hook) into the C-40 Indicator (within the Setting menu).
10. Perform an EMI ground test per AC 43.13-1b section 11-107. For equipment that can only be check in flight an EMI flight test may be required.

4.6 Component Weights

The weights of the primary kit components are listed in Table 4.6.1. The remaining kit components include electrical harnesses and fasteners with a total weight of less than 1.5 lbs.

Table 4.6.1 Component Weights & CGs

Component	Weight lbs (kgs)	Longitudinal CG (STA)	Lateral CG (BL)
Cargo Hook P/N 528-043-00 P/N 528-043-10	18.5 (8.4)	353.0	0.0
Load Indicator P/N 210-293-01	0.55 (0.25)	*	*

*Location is optional in the cockpit.

4.7 Paper Work

In the US, fill in FAA form 337 for the initial installation and submit to the FAA. Keep a copy for aircraft records. This procedure may vary in different countries. Make the appropriate aircraft log book entry. Insert the Rotorcraft Flight Manual Supplement 121-066-00 in the Rotorcraft Flight Manual.

	Owner's Manual Cargo Hook Kit	Document Number 120-224-00	Revision 5
		Date 07/01/24	Page 32 of 39

5.0 Operation Instructions

Refer to Owner's Manual 120-152-00 for operation instructions and changing settings for the C-40 load indicator. Refer to the RFMS 121-066-00 for pre-flight operational checks of the cargo hook and C-40 load indicator.

5.1 Cargo Hook Loading

The cargo hook can easily be loaded with one hand. A load is attached to the cargo hook by pushing the ring upward against the upper portion of the load beam throat, as illustrated in Figure 5.1.1, until an internal latch engages the load beam and latches it in the closed position.

Figure 5.1.1 Cargo Hook Loading

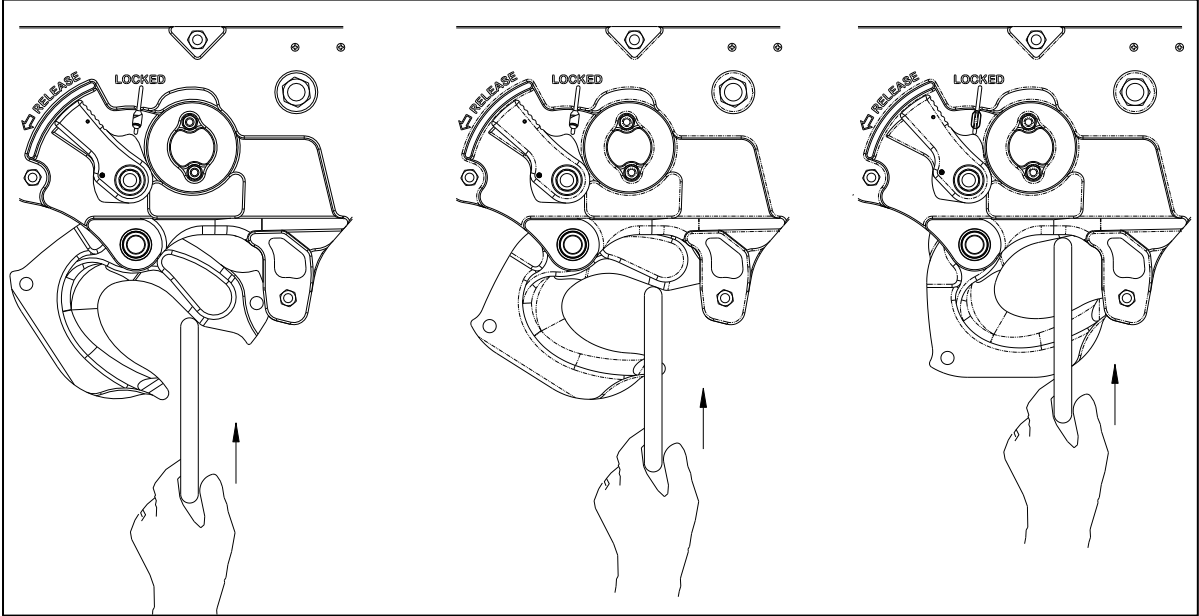

	Owner's Manual Cargo Hook Kit	Document Number 120-224-00	Revision 5
		Date 07/01/24	Page 33 of 39

5.2 Cargo Hook Rigging

Extreme care must be exercised when rigging a load to the Cargo Hook. Steel load rings are recommended to provide consistent release performance and resistance to fouling. Figure 5.1.1 shows the recommended rigging and rigging to avoid, but is not intended to represent all rigging possibilities.



It is the responsibility of the operator to assure the cargo hook will function properly with each rigging.

For a cargo hook with the pin load cell installed, Roller Shackle P/N 232-814-00 (ref. Figure 5.2.1) should be used to enhance the accuracy of the load weigh system. It uses a roller bearing to facilitate the movement of the point of load application to the optimal location on the load beam. This Roller Shackle is sold separately.

5.2.1 Nylon Type Straps and Rope



Multiple load rings, nylon type straps (or similar material) or rope should not be used directly on the cargo hook load beam. If nylon straps or rope must be used they should be first attached to a steel primary ring. Verify that the ring will freely slide off the load beam when it is opened. Only the primary ring should be in contact with the cargo hook load beam.

	Owner's Manual Cargo Hook Kit	Document Number 120-224-00	Revision 5
		Date 07/01/24	Page 34 of 39

Figure 5.2.1 Cargo Hook Rigging for Cargo Hook w/o Load Cell



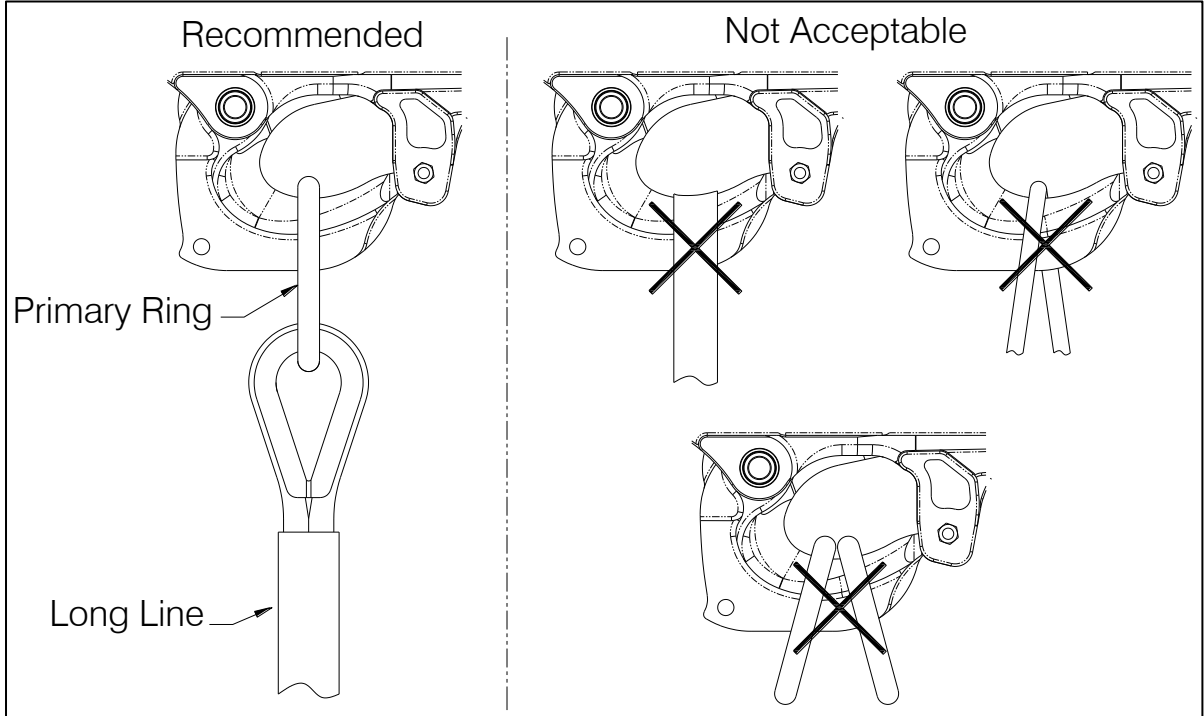

	Owner's Manual Cargo Hook Kit	Document Number 120-224-00	Revision 5
		Date 07/01/24	Page 35 of 39

Figure 5.2.2 Recommended Rigging w/ Load Weigh System

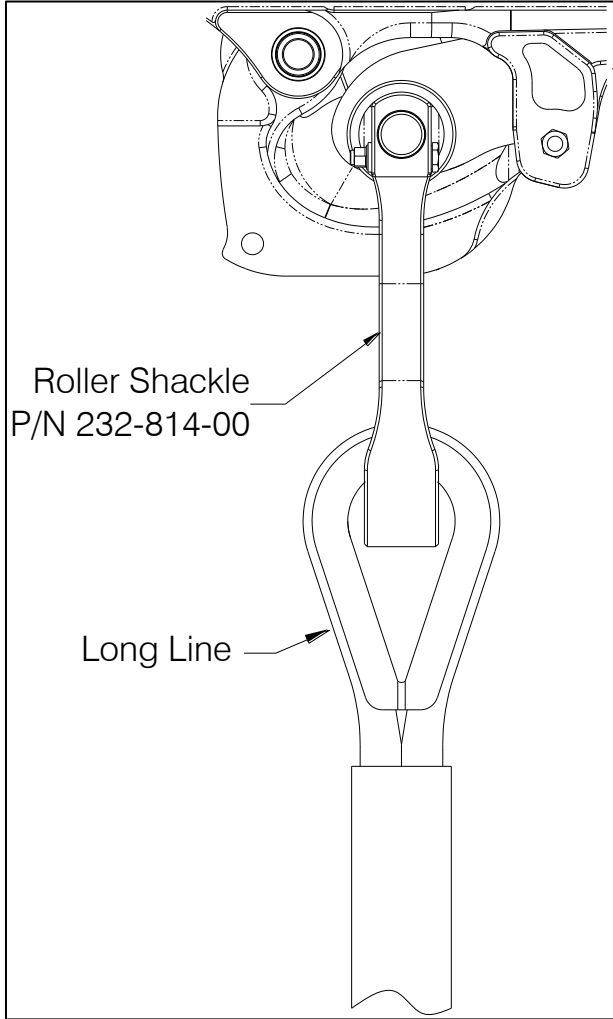

	Owner's Manual Cargo Hook Kit	Document Number 120-224-00	Revision 5
		Date 07/01/24	Page 36 of 39

6.0 Maintenance

Refer to the Instructions for Continued Airworthiness (ICA) manual 123-046-00 for maintenance of the cargo hook kits. For repair and overhaul of cargo hook P/N 528-043-00 and P/N 528-043-10 refer to Cargo Hook Component Maintenance Manual 122-032-00.

6.1 Instructions for Returning Equipment to the Factory

If an Onboard Systems product must be returned to the factory for any reason (including returns, service, repairs, overhaul, etc.) obtain a Return Merchandise Authorization (RMA) number before shipping your return.



An RMA number is required for all equipment returns.

To obtain an RMA, please use one of the listed methods.

- Contact Technical Support by phone or e-mail: (Techhelp@OnboardSystems.com).
- Generate an RMA number at our website: <https://www.onboardsystems.com/support/rma>

After you have obtained the RMA number, please be sure to:

1. Package the component carefully to ensure safe transit.
2. Write the RMA number on the outside of the box or on the mailing label.
3. Include the RMA number and reason for the return on your purchase or work order.
4. Include your name, address, phone and fax number and e-mail (as applicable).
5. Return the components freight, cartage, insurance and customs prepaid to:

Onboard Systems International, LLC
13915 NW 3rd Court
Vancouver, Washington 98685
USA
Phone: 360-546-3072

	Owner's Manual Cargo Hook Kit	Document Number 120-224-00	Revision 5
		Date 07/01/24	Page 37 of 39

7.0 Certification



*United States of America
Department of Transportation
Federal Aviation Administration*
Supplemental Type Certificate

Number: SR02698SE

This certificate issued to: **Onboard Systems International, LLC**
13915 NW 3rd Court
Vancouver, WA 98685

Certifies that the change in the type design for the following product with the limitations and conditions therefore as specified hereon meets the airworthiness requirements of Part 29 *of the Federal Aviation Regulations.*

Original Product *
Type Certificate Number:

Make: *

Model: * See attached Federal Aviation Administration (FAA) Approved Model List (AML) SR02698SE for approved aircraft models and applicable airworthiness regulations.

Description of Type Design Change:

Installation of Onboard Systems International Cargo Hook Kits in accordance with the Master Drawing List (MDL) No. 155 205 00, Revision 5, dated April 20, 2022, or later FAA Approved revision, as listed on the AML. Maintained in accordance with the instructions for Continued Airworthiness (ICA) No. 123-046-00, Revision 1, dated April 5, 2022, or later FAA Accepted revision. Operated in accordance with the Rotorcraft Flight Manual Supplement (RFMS), No. 121-056-00, Revision 1, dated May 11, 2022, or later FAA Approved revision, as listed on the AML.

Limitations and Conditions:

Approval of this change in type design applies to the rotorcraft listed on AML SR02698SE only. This approval should not be extended to other rotorcraft of these models on which other previously approved modifications are incorporated unless it is determined by the installer that the relationship between this change and other previously approved modifications will introduce no adverse effect upon the airworthiness of that rotorcraft. A copy of this certificate, AML SR02698SE, ICA, the Owner's Manual (No. 120-224-00), and RFMS, must be maintained as part of the permanent records for the modified aircraft. Operational approval for external load operations must be granted by the local Aviation Authority. May

If the holder agrees to permit another person to use this certificate to alter the product, the holder shall give the other person written evidence of that permission.

This certificate and the supporting data which is the basis for approval shall remain in effect until surrendered, suspended, revoked, or a termination date is otherwise established by the Administrator of the Federal Aviation Administration.

Date of Application: September 19, 2017 *Date Reissued:* October 7, 2021

Date of Issuance: August 10, 2020 *Date Amended:* May 27, 2022

By Direction of the Administrator

**DOUGLAS Y
TSUJI**
Signature:

Digitally signed by DOUGLAS Y
TSUJI
Date: 2022.05.27 08:19:01
-0700

For Acting Manager, Seattle ACO

Title: Branch

Any alteration of this certificate is punishable by a fine of not exceeding \$1,000, or imprisonment not exceeding 3 years, or both. This certificate may be transferred or made available to third persons by licensing agreements in accordance with 14 CFR 21.47. Possession of this Supplemental Type Certificate (STC) document by persons other than the STC holder does not constitute rights to the design data nor to alter an aircraft, aircraft engine, or propeller. The STC's supporting documentation (drawings, instructions, specifications, flight manual supplements, etc.) is the property of the STC holder. An STC holder who allows a person to use the STC to alter an aircraft, aircraft engine, or propeller must provide that person with written permission acceptable to the FAA. (Ref. 14 CFR 21.126).



Owner's Manual Cargo Hook Kit

Document Number 120-224-00	Revision 5
Date 07/01/24	Page 38 of 39

**FEDERAL AVIATION ADMINISTRATION (FAA) APPROVED MODEL LIST (AML) SR02698SE
FOR
CARGO HOOK KIT**

ISSUE DATE: August 10, 2020

ITEM	AIRCRAFT / ROTORCRAFT MAKE	AIRCRAFT / ROTORCRAFT MODEL	ORIGINAL TC NUMBER	CERTIFICATION BASIS FOR ALTERATION	FAA APPROVED AIRCRAFT / ROTORCRAFT FLIGHT MANUAL SUPPLEMENT		FAA APPROVED MASTER DRAWING LIST		AML REV DATE
					Number	Revision*	Drawing	Revision*	
1.	Delta Enterprise	UH-60A	R00019AT	14 CFR Part 29 Amdt. 29-20	121-066-00	Revision 1, May 11, 2022	155-205-00	Revision 5, 04/20/22	5/27/22
2.	ACE Aeronautics, LLC	UH-60A	R00005RC	14 CFR Part 29 Amdt. 29-20	121-066-00	Revision 1, May 11, 2022	155-205-00	Revision 5, 04/20/22	5/27/22
3.	Unical Aviation, Inc.	UH-60A	R00023LA	14 CFR Part 29 Amdt. 29-20	121-066-00	Revision 1, May 11, 2022	155-205-00	Revision 5, 04/20/22	5/27/22
4.	PJ Helicopters Inc.	UH-60A	R00020LA	14 CFR Part 29 Amdt. 29-20	121-066-00	Revision 1, May 11, 2022	155-205-00	Revision 5, 04/20/22	5/27/22
5.	Timberline Helicopters, Inc.	UH-60A	R00052SE	14 CFR Part 29 Amdt. 29-20	121-066-00	Revision 1, May 11, 2022	155-205-00	Revision 5, 04/20/22	5/27/22
6.	Carson Helicopters, Inc.	UH-60A	R00020AT	14 CFR Part 29 Amdt. 29-20	121-066-00	Revision 1, May 11, 2022	155-205-00	Revision 5, 04/20/22	5/27/22
7.	High Performance Helicopters Corp.	UH-60A	R00054SE	14 CFR Part 29 Amdt. 29-20	121-066-00	Revision 1, May 11, 2022	155-205-00	Revision 5, 04/20/22	5/27/22
8.	BHI H60 Helicopters, LLC	UH-60A	R0012DE	14 CFR Part 29 Amdt. 29-20	121-066-00	Revision 1, May 11, 2022	155-205-00	Revision 5, 04/20/22	5/27/22
9.	Skydance Blackhawk Operations, LLC	UH-60A	R00022LA	14 CFR Part 29 Amdt. 29-20	121-066-00	Revision 1, May 11, 2022	155-205-00	Revision 5, 04/20/22	5/27/22
10.	Billings Flying Service Inc.	UH-60A	R00021LA	14 CFR Part 29 Amdt. 29-20	121-066-00	Revision 1, May 11, 2022	155-205-00	Revision 5, 04/20/22	5/27/22
11.	SixtyHawk TC, LLC	EH-60A HH-60L UH-60A	R00025LA	14 CFR Part 29 Amdt. 29-20	121-066-00	Revision 1, May 11, 2022	155-205-00	Revision 5, 04/20/22	5/27/22
12.	Capitol Helicopters Inc.	HH-60L UH-60A	R00026LA	14 CFR Part 29 Amdt. 29-20	121-066-00	Revision 1, May 11, 2022	155-205-00	Revision 5, 04/20/22	5/27/22
13.	Reeder Flying Service Inc.	UH-60A	R00027LA	14 CFR Part 29 Amdt. 29-20	121-066-00	Revision 1, May 11, 2022	155-205-00	Revision 5, 04/20/22	5/27/22
14.	HeliQwest International Inc.	EH-60A UH-60A	R00028LA	14 CFR Part 29 Amdt. 29-20	121-066-00	Revision 1, May 11, 2022	155-205-00	Revision 5, 04/20/22	5/27/22
15.	Northwest Rotorcraft LLC	UH-60A	R00058SE	14 CFR Part 29 Amdt. 29-20	121-066-00	Revision 1, May 11, 2022	155-205-00	Revision 5, 04/20/22	5/27/22
16.	Pickering Aviation, Inc.	EH-60A UH-60A	R00003AC	14 CFR Part 29 Amdt. 29-20	121-066-00	Revision 1, May 11, 2022	155-205-00	Revision 5, 04/20/22	5/27/22

* Or later FAA Approved Revision

	Owner's Manual Cargo Hook Kit	Document Number 120-224-00	Revision 5
		Date 07/01/24	Page 39 of 39

FEDERAL AVIATION ADMINISTRATION (FAA) APPROVED MODEL LIST (AML) SR02698SE FOR CARGO HOOK KIT	ISSUE DATE: August 10, 2020
FAA Approved: _____	For Acting Manager, Seattle Aircraft Certification Office
AMENDED: August 10, 2020, May 27, 2022	
REISSUED:	
Page 2 of 2	