

**PLEASE CHECK WEB SITE AT WWW.ONBOARDSYSTEMS.COM FOR
THE LATEST REVISION OF THIS MANUAL**

**Talon LC Keeperless
Cargo Hook Kit
For the
Lama series helicopters**

**Cargo Hook Kit, H-Frame, Part Number 200-270-00
Cargo Hook Kit, Frame Swing, Part Number 200-271-00**

Owner's Manual

*Owner's Manual Number 120-100-00
Revision 5
October 26, 2009*



**13915 NW 3rd Court Vancouver Washington 98685 USA
Phone: 360-546-3072 Fax: 360-546-3073 Toll Free: 800-275-0883
www.OnboardSystems.com**

This page intentionally left blank.

Record of Revisions

<i>Revision</i>	<i>Date</i>	<i>Page(s)</i>	<i>Reason for Revision</i>
1	9/17/02	Title, 4-4	Factory address change.
2	10/10/03	1-1, 1-2, 2-8, and 4-1	528-023-01 cargo hook configuration change Reference Service Bulletin 159-011-00
3	09/22/05	2-3, 2-7 3-3, Section 4	Added additional instruction and clarification to manual release cable rigging (pages 2-3, 2-7). Added Cargo Hook Loading section. Added reference to cargo hook service manual within section 4 and removed duplicate information from this manual.
4	09/17/07	TOC, Section 1, 2-3, 2-8 to 2-10, 3-1 and 3-2	Added warnings, cautions and notes explanation to general information section. Updated warnings, cautions and notes format throughout.
5	10/26/09	2-2, 2-3, 2-7, 2-8	Added caution notes and revised Figure 2-3 and Figure 2-8.

Register Your Products for Automatic Notifications

Onboard Systems offers a free notification service via fax or email for product alerts and documentation updates. By registering your Onboard Systems products at our website, we will be able to contact you if a service bulletin is issued, or if the documentation is updated.

You can choose to receive notices on an immediate, weekly, or monthly schedule via fax, email or both methods. There is no charge for this service. Please visit our website at www.onboardsystems.com/notify.php to get started.

This page intentionally left blank.

CONTENTS

Section 1 **General Information**

Introduction, 1-1
Warnings, Cautions and Notes, 1-1
Bill of Materials, 1-2
Inspection, 1-3
Specifications, 1-3
Theory of Operation, 1-4

Section 2 **Installation Instructions**

Installation Instructions, 2-1
Removal of Existing Cargo Hook, 2-1
Installation Instructions, H-Frame, 2-1
 Hook to H-Frame Installation, 2-1
 Manual Release Cable Installation, 2-2
 Electrical Release Cable Installation, 2-3
 Adel Clamp Installation, 2-4
Installation Instructions, Swing Frame, 2-5
 Bungee Bracket Installation, 2-5
 Hook to Gimbal Joint Installation, 2-6
 Hook Bumper Installation, 2-6
 Bungee Installation, 2-7
 Manual Release Cable Installation, 2-7
 Electrical Release Cable Installation, 2-8
Precautions, 2-9
Installation Check-Out, 2-10
Component Weights, 2-10
Cargo Hook Location, 2-10
Paper Work, 2-10

Section 3 **Operation Instructions**

Operating Procedures, 3-1
Cargo Hook Rigging, 3-2
Cargo Hook Loading, 3-3

Section 4 **Maintenance**

Inspection, 4-1
Adapter Overhaul, 4-1
Instructions for Returning a System to the Factory, 4-2

CONTENTS, continued

Section 5 Certification

- FAA STC, 5-1
- Canadian STC, 5-2
- Austro Control (EASA) STC, 5-3

Figures

- 2-1 Hook to H-Frame Installation, 2-1
- 2-2 Manual Release Cable Rig H frame, 2-2
- 2-3 Manual Release Cable Rig Adjusting, 2-3
- 2-4 Adel Clamp mounting, 2-4
- 2-5 Bungee Bracket Installation, 2-5
- 2-6 Hook to Gimbal Installation, 2-6
- 2-7 Hook Bumper Installation, 2-7
- 2-8 Manual Release Cable Rig, 2-8
- 2-9 Un-commanded Release From Incorrectly Secured Cable, 2-8
- 3-1 Examples of Recommended Cargo Hook Rigging, 3-2
- 3-2 Cargo Hook Loading, 3-3

Tables

- 1-1 Bill of Materials, 1-2
- 1-2 P/N 528-023-01 Cargo Hook Specifications, 1-3
- 2-1 Cargo Hook Connector, 2-3
- 2-2 Component Weights, 2-10
- 4-1 Inspection, 4-1

Section 1

General Information

Introduction

The P/N 200-270-00 Cargo Hook Kit is approved as a replacement on the Lama SA 315B when modified by STC SH1735SW, which includes the ERC H-Frame 17112 and cargo hook 14027-4.

The P/N 200-271-00 Cargo Hook Kit is approved as a replacement on the Lama SA315B when equipped with the Hook A90B-100, Frame 315A73-10-120 and Gimbal 3160S73-06-517.

Warnings, Cautions & Notes

The following definitions apply to Warnings, Cautions & Notes used in this manual.



Means that if this information is not observed, serious injury, death or immediate loss of flight safety could occur.



Means that there is a risk of injury or degradation in performance of equipment if this information is not observed.



Draws the reader's attention to information which may not be directly related to safety, but which is important or unusual.

Bill of Materials

The following items are included as listed in the H-Frame Kit P/N 200-270-00 and Swing Frame Kit P/N 200-271-00. If shortages are found contact the company from whom the system was purchased.

Table 1-1 Bill of Materials

Part Number	Description	H-Frame Kit quantities 200-270-00	Swing Frame Kit quantities 200-271-00
120-100-00	Owner's Manual	1	1
121-010-00	RFM supplement	1	1
122-005-00	Cargo Hook Service Manual	1	1
232-070-00	Hook to Gimbal Adapter, H-Frame	1	-
232-071-00	Hook to Gimbal Adapter, Swing	-	1
290-332-00	Load Bolt	1	-
290-426-00	Hook to Manual Release Adapter	1	-
290-524-00	Hook Bumper	-	2
290-532-00	Hook to Manual Release Adapter	-	1
410-131-00	Electrical Connector	1	1
510-042-00	Washer AN960-10	2	2
510-091-00	Nut, 6-32 Esna	-	4
510-138-00	Screw, 6-32 1¼ FH SS	-	4
510-170-00	Nut, AN320-C6	1	-
510-174-00	Washer NAS1149F 0663P	1	-
510-178-00	Cotter Pin, MS24665-302	1	-
510-183-00	Washer, AN960-816L	1	-
510-252-00	Jam Nut, NAS 509-5C	1	1
510-257-00	Bolt NAS6603-H1	2	2
510-278-00	Washer, AN960-6	-	4
512-010-00	Adel Clamp	2	1
512-021-00	Adel Clamp #20	-	4
528-023-01	Cargo Hook	1	1

Inspection

Inspect the kit items for evidence of damage, corrosion and security of lock wire and fasteners. If damage is evident, do not use the items until they are repaired.

Specifications

Table 1-2 P/N 528-023-01 Cargo Hook Specifications

Design load	3,500 lb. (1,580 kg.)
Design ultimate strength	13,125 lb. (5,952 kg.)
Electrical release capacity	8,750 lb. (3,970 kg.)
Mechanical release capacity	8,750 lb. (3,970 kg.)
Force required for mechanical release at 3,500 lb.	8 lb. Max. (.600" travel)
Electrical requirements	22-32 VDC 6.9 - 10 amps
Minimum release load	0 pounds
Unit weight	3.0 pounds (1.35 kg.)
Mating electrical connector	PC06A8-2S SR

Theory of Operation

The primary elements of the Cargo Hook are the load beam, the internal mechanism, and a DC solenoid. The load beam supports the load and is latched through the internal mechanism. The DC solenoid, an external manual release cable, and a manual release lever provide the means for unlatching the load beam.

The load is attached to the load beam by passing the cargo sling ring into the throat of the load beam and pushing the ring against the upper portion of the load beam throat, which will initiate the hook to close. In the closed position, a latch engages the load beam and latches it in this position.

To release the load, the latch is disengaged from the load beam. With the latch disengaged, the weight of the load causes the load beam to swing to its open position, and the cargo sling slides off the load beam. The load beam then remains in the open position awaiting the next load.

A load release can be initiated by three different methods. Normal release is achieved by pilot actuation of the push-button switch in the cockpit. When the push-button switch is pressed, it energizes the DC solenoid in the Cargo Hook, and the solenoid opens the latch in the internal mechanism. In an emergency, release can be achieved by operating a mechanical release cable. The release cable operates the internal mechanism of the Cargo Hook to unlatch the load beam. The load can also be released by the actuation of a lever located on the side of the Cargo Hook.

This page intentionally left blank.

Section 2

Installation Instructions

These procedures are provided for the benefit of experienced aircraft maintenance facilities capable of carrying out the procedures. They must not be attempted by those lacking the necessary expertise.

Removal of Existing Cargo Hook

Remove the old Cargo Hook from the aircraft by disconnecting the hook from the universal (gimbal) adapter on the H-frame or Swing frame. Disconnect the manual and electrical release cables at the hook.

Installation Instructions, H-Frame

Hook to H-Frame Installation

Attach the new Cargo Hook to the Hook to Gimbal Adapter as shown below. The 232-070-00 Hook to Gimbal adapter is installed with the longer lower arm pointing to the rear of the hook. The interface tab on the adapter will prevent installation of the adapter in the opposite orientation. Attach the Hook to Gimbal adapter to the H-Frame Gimbal using the hardware supplied, as illustrated below. The cargo hook load beam should point forward.

Figure 2-1 Hook to H-Frame Installation

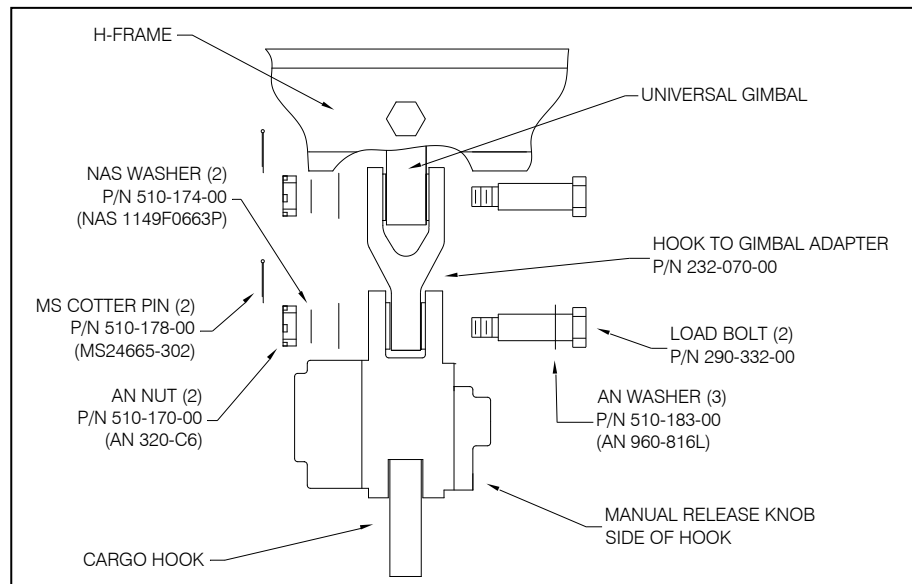

In two places, torque nut 510-170-00 on bolt 290-332-00 to 50 in-lb., then rotate nut to next castellation, not to exceed 110 in-lbs. Install and secure cotter pin 510-178-00.

Cargo Hook Installation, H-Frame, continued

Manual Release Cable Installation

Locate the Manual Release Cable and hold downs as illustrated below. As various Load Cell configurations may be utilized the exact routing and position of the cable and hold downs should be determined upon installation. In determining the location make sure that the Cargo Hook is free to move in all possible direction without straining or kinking the Manual Release Cable, and that the bend radius of the mechanical release cable is as large as possible.

Because the new cargo hook provides additional ground clearance, use of the original bungee cord is optional. If needed, install the Bungee cord as illustrated below in figure 2-2 and figure 2-4.

Figure 2-2 Manual Release Cable Rig H-frame

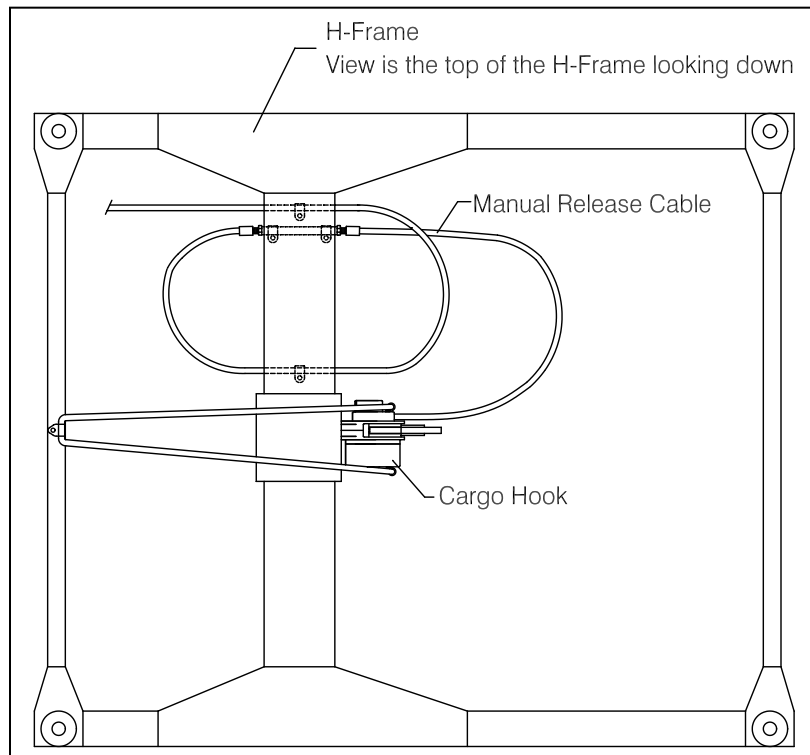

Remove the manual release cover from the new cargo hook. Thread the hook to manual release adapter, P/N 290-426-00 into the new cargo hook manual release boss on the hook sideplate. Place the cable ball end fitting into the hook manual release lever fork as illustrated in Figure 2-3. Rotate the manual release lever in the clockwise direction to remove free play (this is readily felt as the lever moves easily for several degrees before encountering greater resistance) . Measure the cable ball end free play with the manual release handle in the cockpit in the non-release position and the cargo hook in the closed and locked position. Adjust the manual release cable system for a minimum of .125" of freeplay at the fork fitting as shown in Figure 2-3. Tighten the jam nut against the hook and secure with safety wire. Replace the manual release cover and secure the screws with safety wire.

Cargo Hook Installation, H-Frame, continued



Manual release cable rigging must be done with the cargo hook load beam in the closed and locked position.

Figure 2-3 Manual Release Cable Adjusting

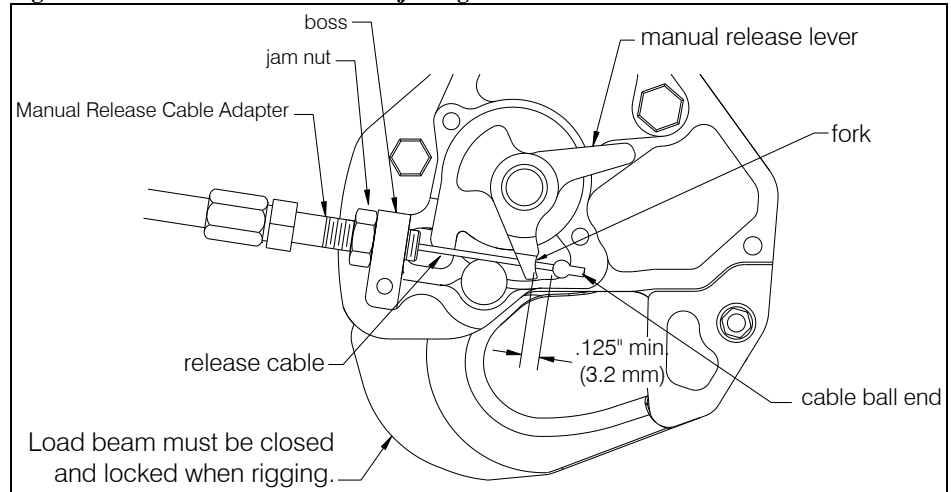

Electrical Release Cable Installation

It will be necessary to replace the connector on the electrical release cable with the one supplied with the Cargo Hook Kit.

Connect the cargo hook electrical release cable connector to the Cargo Hook and belly mounted bulk-head receptacle and safety wire the connector. Listed below is the pin out for the cargo hook connector.

Table 2-1 Cargo Hook Connector

<i>Pin</i>	<i>Function</i>
A	Ground
B	Positive



The Cargo Hook is equipped with a suppression diode that will be damaged if the Cargo Hook electrical connections are reversed. Do not attach the electrical connector until the polarity of the aircraft connector is determined to be compatible with the Cargo Hook connector listed in Table 2-1.

Cargo Hook Installation, H-Frame, continued

Adel Clamp Installation

Re-use of the bungee cord, used to secure the cargo hook, is optional. The new cargo hook provides additional ground clearance making its use unnecessary in most conditions. If the bungee cord is to be used secure the 2 supplied adel clamps, P/N 512-010-00, to the cargo hook bolts using P/N 510-257-00 bolts and P/N 510-042-00 washers as illustrated below. Torque the bolts to 20-25 in-lbs. Secure the bolts with safety wire.

Figure 2-4 Adel Clamp mounting

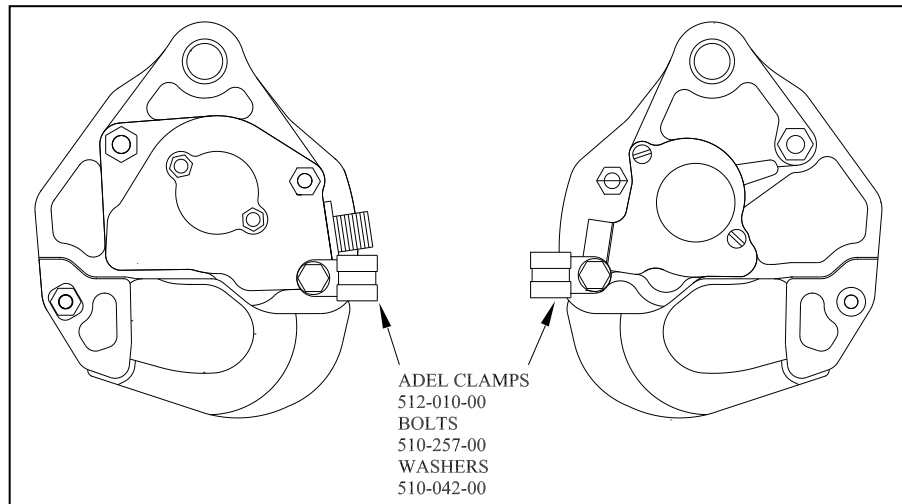

The H-frame installation is complete at this point, proceed to the installation checkout.

Installation Instructions Swing-Frame

Bungee Bracket Installation

Re-use of the Bungee cord, used to secure the cargo hook is optional. The new cargo hook provides additional ground clearance, making the bungee cords use unnecessary in most conditions. If the bungee cord is to be used, attach the Adel Clamp P/N 512-010-00 to the manual release side of the cargo hook with a P/N 510-257-00 bolt and P/N 510-042-00 washer as illustrated. Torque the bolt to 20-25 in-lbs.

Figure 2-5 Bungee Bracket Installation

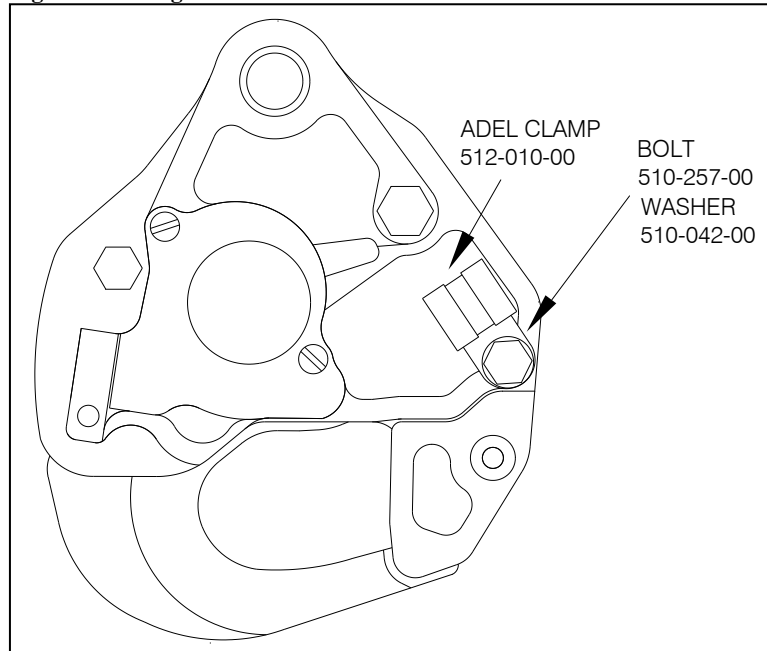

Cargo Hook Installation, Swing Frame, continued

Hook to Gimbal Joint Installation

Inspect the swing assembly components to ensure that they are in serviceable condition. Attach the new Cargo Hook to the Gimbal Adapter. The 232-071-00 Gimbal adapter is installed on the cargo hook with the longer lower arm pointing to the rear of the hook. The hook interface tab on the adapter will prevent installation of the adapter in the opposite orientation. Attach the cargo hook and Gimbal adapter to the Swing Frame Gimbal, using existing hardware and the hardware supplied as illustrated below. The cargo hook load beam should point aft.

Figure 2-6 Hook to Gimbal Installation

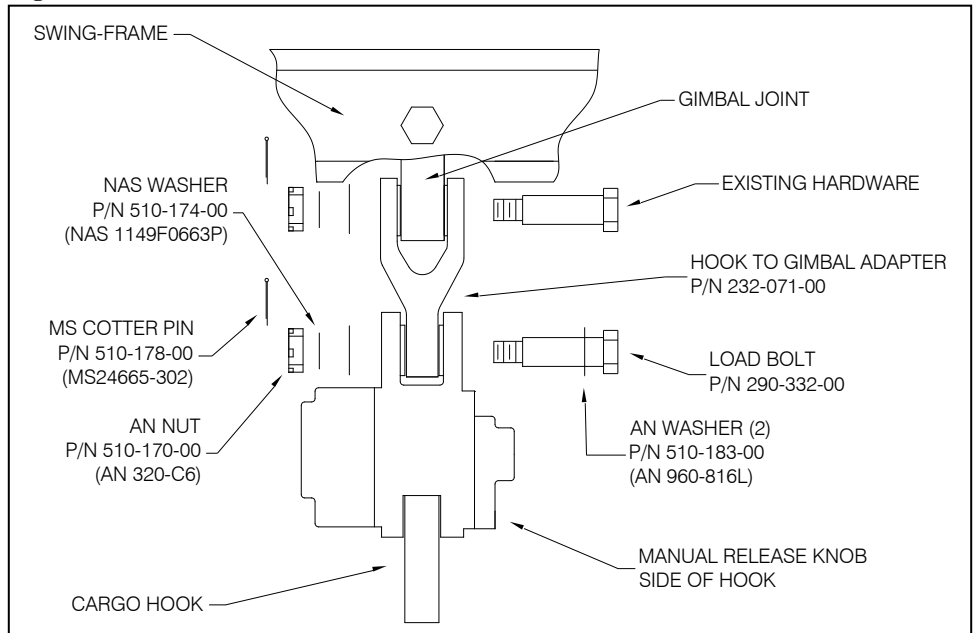

In two places, torque nut 510-170-00 on bolt 290-332-00 to 50 in-lb., then rotate nut to next castellation, not to exceed 110 in-lbs. Install and secure cotter pin 510-178-00.

Hook Bumper Installation

Attach the two Hook Bumpers to the Swing Frame, as illustrated in figure 2-7 using the hardware provided. Do not use the new hook without the Hook Bumpers as they protect the manual release fitting and the electrical release connector from damage when the hook swings about.

Cargo Hook Installation, Swing Frame, continued

Figure 2-7 Hook Bumper Installation

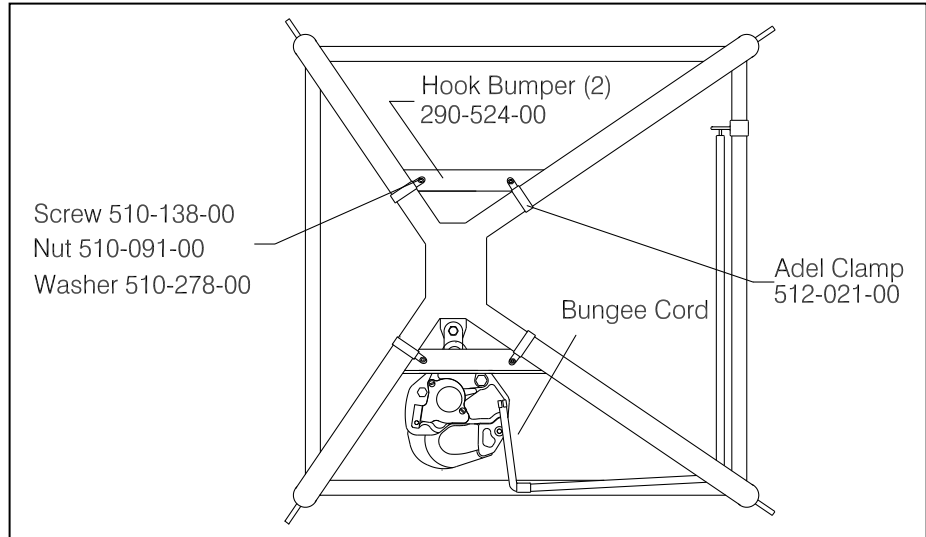

Bungee Installation

Attach the bungee hook to the adel clamp on the cargo hook.

Manual Release Cable Installation

Remove the manual release cover from the new Cargo Hook. Thread the Hook to Manual Release Adapter, P/N 290-532-00 into the new Cargo Hook. Connect the manual release cable to the Adapter. Place the cable ball end fitting into the hook manual release lever fork as illustrated in Figure 2-8. Rotate the manual release lever in the clockwise direction until the boss on its underside contacts the cam stop and hold in this position. Measure the cable ball end free play with the manual release handle in the cockpit in the non-release position. Adjust the manual release cable system for a minimum of .125" of freeplay at the fork fitting as shown in Figure 2-8.

Cargo Hook Installation, Swing Frame, continued



Manual release cable rigging must be done with the cargo hook in the closed and locked position.

Figure 2-8 Manual Release Cable Rig

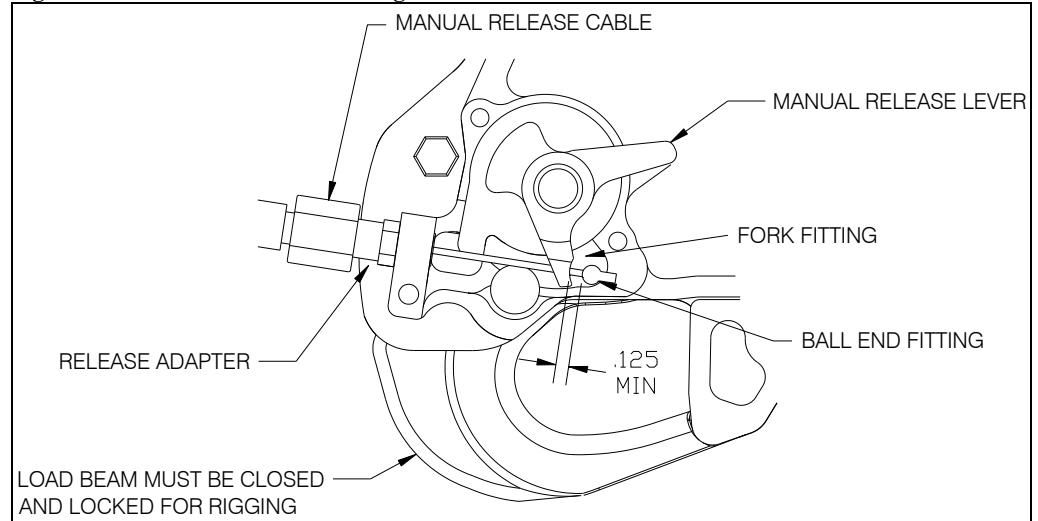

Electrical Release Cable Installation

It will be necessary to replace the connector on the electrical release cable with the one supplied with the Cargo Hook Kit. See table 2-1 for the pin out for the cargo hook connector and corresponding wire numbers.

Wire NM10T4 is for a hook open indicator light. The P/N 528-023-01 Cargo Hook does not have a hook open switch. Insulate and secure the end of this wire. If hook open indication is desired, contact the factory as this feature can be added to the P/N 528-023-01 Cargo Hook.

Connect the cargo hook electrical release cable connector to the Cargo Hook and secure with safety wire.



The Cargo Hook is equipped with a suppression diode that will be damaged if the Cargo Hook electrical connections are reversed. Do not attach the electrical connector until the polarity of the aircraft connector is determined to be compatible with the Cargo Hook connector listed in Table 2-1.

Precautions



Un-commanded cargo hook release will happen if the manual and electrical release cables are improperly restrained. The cables must not be the stops that prevent the Cargo Hook from swinging freely in all directions. If the Cargo Hook loads cause the hook to strain against the manual release cable the swaged end of the cable may separate allowing the inner cable to activate the cargo hook manual release mechanism. The result is an un-commanded release. Ensure that no combination of cyclic stick or Cargo Hook position is restrained by the manual or electrical release cables.

Figure 2-9 Un-commanded Release From Incorrectly Secured Cable

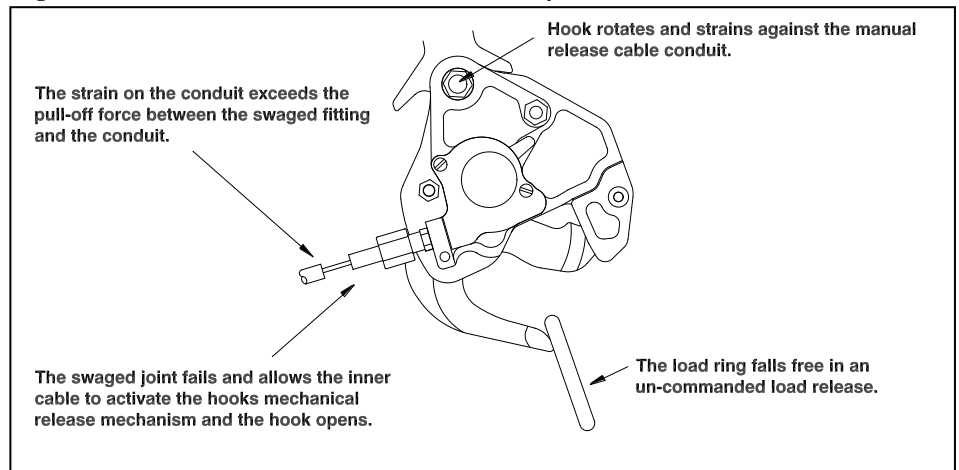

Installation Check-Out

After installation of the Cargo Hook Kit, perform the following functional checks.

1. Swing the installed Cargo Hook to ensure that the manual release cable assembly and the electrical release cable have enough slack to allow full swing of the suspension assembly without straining or damaging the cables. The cables must not be the stops that prevent the Cargo Hook from swinging freely in all directions.
2. With no load on the cargo hook load beam, pull the handle operated cargo hook mechanical release, the Cargo Hook should release. Reset the cargo hook load beam.
3. Close the cargo hook release circuit breaker and position the battery switch to the ON position. With no load on the cargo hook load beam, depress the cargo hook electrical release button, the Cargo Hook should release. Reset the cargo hook load beam.
4. See the service instructions for your specific helicopter model for additional installation instructions.

Component Weights

The weight of the Cargo Hook Kit components are listed below.

Table 2-2 Component Weights

Item	Weight lbs (kgs)
Cargo Hook	3.0 (1.36)
Manual Release Cable	1.0 (0.45)
Electrical Release Cable	0.5 (0.23)

Cargo Hook Location

See the Eurocopter provided Flight Manual Supplement for External Load weight and balance data.

Paper Work

In the US, fill in FAA form 337 for the initial installation. This procedure may vary in different countries. Make the appropriate aircraft log book entry. Insert the Rotorcraft Flight Manual Supplement 121-010-00 into the Rotorcraft Flight Manual.

Section 3

Operation Instructions

Operating Procedures

Prior to each cargo hook use perform the following:

1. Ensure that the Cargo Hook Kit has been properly installed and that the manual and electrical release cables do not limit the movement of the hook.
2. Be completely familiar with this Owner's Manual.
3. Be completely familiar with all the aircraft's Cargo Hook operating instructions.
4. Activate the electrical system and press the Cargo Hook release button to ensure the cargo hook electrical release is operating correctly. The mechanism should operate smoothly and the Cargo Hook must release. Reset the hook by hand after the release. If the hook does not release or re-latch, do not use the unit until the difficulty is resolved.



The release solenoid is intended to be energized only intermittently. Depressing the electrical release button continuously in excess of 20 sec. will cause the release solenoid to overheat, possibly causing permanent damage.

5. Activate the manual release lever to test the cargo hook manual release mechanism. The mechanism should operate smoothly and the Cargo Hook must release. Reset the hook by hand after release. If the hook does not release or re-latch do not use the unit until the difficulty is resolved.

See the Cargo Hook Service Manual 122-005-00 and the aircraft's service instructions that cover the original Cargo Hook installation for additional instructions.

Cargo Hook Rigging

Extreme care must be exercised when rigging a load to the Cargo Hook. Steel load rings are recommended to provide consistent release performance and resistance to fouling. The following illustration shows the recommended rigging, but is not intended to represent all rigging possibilities.



Some combinations of small primary rings and large secondary rings could cause fouling during release.

It is the responsibility of the operator to assure the cargo hook will function properly with each rigging.

Nylon Type Straps and Rope



Nylon type straps (or similar material) or rope must not be used directly on the cargo hook load beam. If nylon straps or rope must be used they should be first attached to a steel primary ring. Verify that the ring will freely slide off the load beam when it is opened. Only the primary ring should be in contact with the cargo hook load beam.

Figure 3-1 Example of Recommended Cargo Hook Rigging

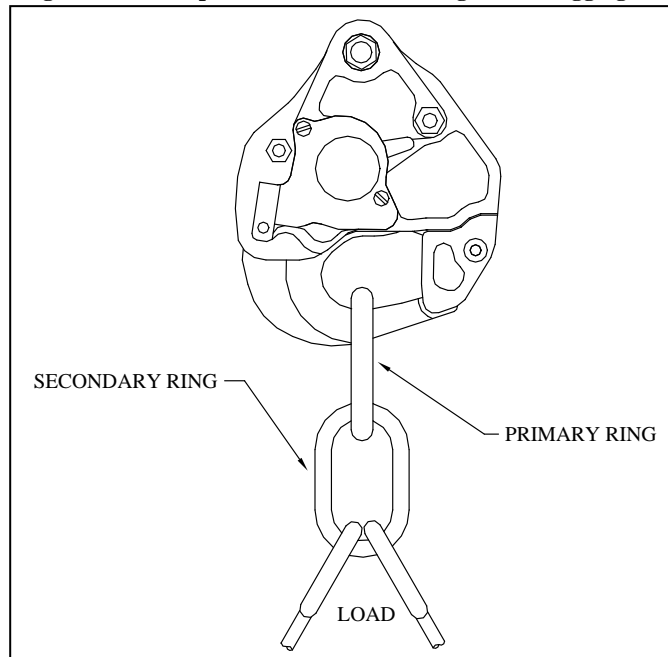

Cargo Hook Loading

The cargo hook can easily be loaded with one hand. A load is attached to the hook by pushing the ring upward against the upper portion of the load beam throat, as illustrated in Figure 3-2, until an internal latch engages the load beam and latches it in the closed position.

Figure 3-2 Cargo Hook Loading

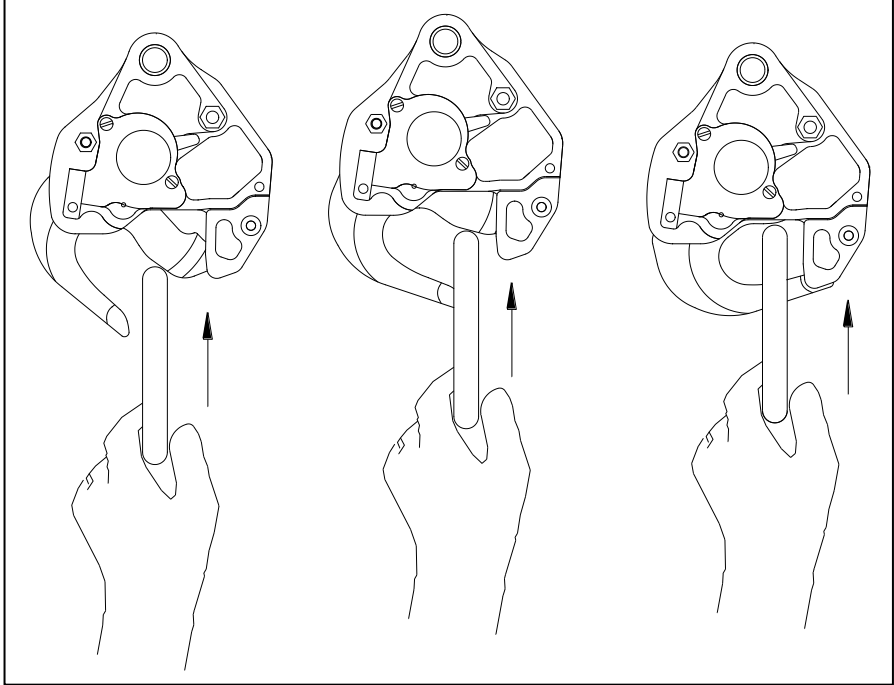

This page intentionally left blank.

Section 4

Maintenance

Refer to Service Manual 122-005-00 for detailed maintenance information for the Cargo Hook.

Inspection

The inspection of the Cargo Hook Kit shall be in accordance with the table 4-1 shown below.

Table 4-1 Inspection

Part Number	Daily Inspection	At Overhaul Interval*
528-023-01 Cargo Hook	Refer to Service Manual 122-005-00.	Refer to Service Manual 122-005-00.
232-070-00 232-071-00 Gimbal Adapter	Inspect for security of attachment, fasteners, excessive wear or cracks. Replace if damage or cracks found.	Inspect to the requirements of this manual. Overhaul at the same interval as the Cargo Hook.

* Refer to Service Manual 122-005-00 for overhaul interval for the Cargo Hook.

Adapter Overhaul

Carefully inspect the adapter in accordance with Table 4-1 in a clean, well lit room.

Inspect the bushing and bearing surfaces for wear and corrosion. Pitting, corrosion or excessive wear is cause for rejection. Maximum permissible bushing clearance is .004" on diameter.

Perform Magnetic Particle Inspection on adapter 232-070-00 (or 232-071-00) in accordance with ASTM E-1444 and MIL-STD-1907, Grade A. No cracks are permitted.

Instructions for Returning Equipment to the Factory

If an Onboard Systems product must be returned to the factory for any reason (including returns, service, repairs, overhaul, etc) obtain an RMA number before shipping your return.



An RMA number is required for all equipment returns.

- To obtain an RMA, please use one of the listed methods.
 - Contact Technical Support by phone or e-mail (Techhelp@OnboardSystems.com).
 - Generate an RMA number at our website: <http://www.onboardsystems.com/rma.php>
- After you have obtained the RMA number, please be sure to:
 - Package the component carefully to ensure safe transit.
 - Write the RMA number on the outside of the box or on the mailing label.
 - Include the RMA number and reason for the return on your purchase or work order.
 - Include your name, address, phone and fax number and email (as applicable).
 - Return the components freight, cartage, insurance and customs prepaid to:

Onboard Systems
13915 NW 3rd Court
Vancouver, Washington 98685
USA
Phone: 360-546-3072

Appendix A Certification Documentation

FAA STC

United States of America

Department of Transportation—Federal Aviation Administration

Supplemental Type Certificate

Number SR00897SE

This certificate, issued to: **Onboard Systems**
13915 NW 3rd Court
Vancouver, WA 98685

certifies that the change in the type design for the following product with the limitations and conditions therefor as specified hereon meets the airworthiness requirements of Part 6 of the Civil Air Regulations.

Original Product—Type Certificate Number H11N
Make: Eurocopter
Model: SA 315B

Description of the Type Design Change: Fabrication of Onboard Model 200-270-00 (H-Frame) or 200-271-00 (Frame Swing) cargo hook system in accordance with Onboard Master Drawing List No. 155-065-00, dated January 26, 2001, or later FAA approved revision; and installation and inspection of these Onboard cargo hook systems in accordance with FAA approved Onboard Cargo Hook Owner's Manual, Document 120-100-00, dated January 25, 2001, and Cargo Hook Service Manual, Document 122-005-00, Revision 1, dated November 9, 2000, or later FAA approved revisions.

Limitations and Conditions: Approval of this change in type design applies to only those Eurocopter Model SA 315B rotorcraft listed above, which were previously equipped with an FAA approved installation of a Siren Model A90B hook, or those modified by the installation of a Breeze-Eastern P/N 14027-4 hook per STC No. SH1735SW. This approval should not be extended to other rotorcraft of this model on which other previously approved modifications are incorporated unless it is determined by the installer that the relationship between this change and any of those other previously approved modifications, including changes in type design, will introduce no adverse effect upon the airworthiness of that rotorcraft. This modification has been approved by the FAA for Class B and C Rotorcraft-Load Combinations, Non-human External Cargo only. Modified rotorcraft must be operated in accordance with FAA approved Onboard Rotorcraft Flight Manual Supplement (RFMS) No. 121-010-00, dated March 26, 2001, or later FAA approved revision. A copy of this Certificate and FAA approved RFMS must be maintained as part of the permanent records for the modified rotorcraft.

If the holder agrees to permit another person to use this certificate to alter the product, the holder shall give the other person written evidence of that permission.

This certificate and the supporting data which is the basis for approval shall remain in effect until surrendered, suspended, revoked, or a termination date is otherwise established by the Administrator of the Federal Aviation Administration.

Date of application: September 22, 2000

Date reissued:

Date of issuance: March 26, 2001

Date amended: May 17, 2001; January 13, 2003



By deposition of the Administrator

Richard Simpson
(Signature)

Acting Manager, Seattle Aircraft
Certification Office

(Title)

Any alteration of this certificate is punishable by a fine of not exceeding \$1,000, or imprisonment not exceeding 3 years, or both.

This certificate may be transferred in accordance with FAR 21.47.

Canadian STC



Transport
Canada

Transports
Canada

Aviation

Aviation

Suite 620
800 Burrard Street
Vancouver, B.C.
V6Z 2J8

Your file *Voire référence*
190S-01-370
Our file *Notre référence*
01-2249

June 25, 2001

Mr. Ron Pirtle
Data Manager
Onboard Systems International
11212 N.W. St. Helen's Road
Portland, OR
97231 USA

Dear Mr. Pirtle,

Subject: Acceptance of FAA STC SR00897SE

This is in response to the FAA Seattle ACO letter dated June 1, 2001, requesting Transport Canada approval of the subject STC.

In accordance with our current policy associated with the review of foreign STCs, some STCs applicable to certain categories of aircraft may be accepted solely on the basis of their foreign certification, and do not require the issue of a corresponding certificate by Transport Canada. The subject STC falls within these criteria.

This STC will be entered in the national index of STCs that have been reviewed and accepted by Transport Canada for installation on Canadian registered aeronautical products.

This letter confirms formal acceptance of the referenced STC by Transport Canada.

Yours truly,

Henry Wong
for
Regional Manager
Aircraft Certification

c.c. Ms. Dorenda Baker, Acting Manager Seattle Aircraft Certification Office

Canada 

1/1

Austro Control (EASA) STC



a member of

JOINT AVIATION AUTHORITIES

SUPPLEMENTAL TYPE CERTIFICATE

ACG.21NE2.081

Pursuant to the National Regulations for the time being in force and subject to the conditions and limitations specified below, Austro Control in accordance with the JAA Supplemental Type Certificate Procedures hereby certifies to:

Onboard Sytems International

11212 NW St. Helens Road
Portland, OR
97231 USA

that the change in the Type Design to the following product, as specified herein, meets the appropriate CAR 6 and FAR 27 requirements.

Basic Product- *Type Certificate Number:* DGAC Fiche N° 61
Type: SA 315B

STC Title: 3,5K Keeperless Cargo Hook Kit, Lama series
STC Definition Document: Master Drawing List No. 155-065-00 dated January 26, 2001 or later approved revision.

Conditions and Limitations:

- 1) Compatibility of this installation with previous installed equipment must be determined by the installer.
- 2) Subject to compliance with the provisions of §36 ZLLV 1999 and JAR-21 Subpart E [or N-E], this Certificate and associated data shall remain valid until surrendered, withdrawn or other terminated.
- 3) If transfer of the Certificate is requested under JAR-21.116 or 21N116, the Certificate will be reissued.
- 4) This STC requires compliance with the JAA procedures for STC's.
- 5) This STC is based on the FAA STC SR008975E to FAA Type Certificate H1IN. All limitations remain active.

Date of application: 10. May 2002

Date of issue: 29. November 2002

Signed: 

For AUSTRO CONTROL GmbH