

**PLEASE CHECK WEB SITE AT [WWW.ONBOARDSYSTEMS.COM](http://WWW.ONBOARDSYSTEMS.COM) FOR  
THE LATEST REVISION OF THIS MANUAL**

**TALON CAROUSEL  
REMOTE  
CARGO HOOK**

*Part Number*

**528-021-00**

**528-021-01**

**210-242-00**

*Owner's Manual*

*Owner's Manual Number 120-087-00*

*Revision 16*

*09/09/15*



*13915 NW 3<sup>rd</sup> Court Vancouver Washington 98685 USA  
Phone: 360-546-3072 Fax: 360-546-3073 Toll Free: 800-275-0883  
[www.OnboardSystems.com](http://www.OnboardSystems.com)*

This page intentionally left blank.

## RECORD OF REVISIONS

<i>Revision</i>	<i>Date</i>	<i>Page(s)</i>	<i>Reason for Revision</i>
6	02/03/10	All	Changed overhaul frequency criteria. Added P/N 210-242-00 and 528-021-01. Corrected Figure 4-2.
7	07/16/10	4-11,4-12	Changed attach hardware for 210-242-00. Updated figure 4-3 and table 4-5.
8	07/28/10	Section 1, Section 2, Section 3, 4-6, 4-11 & 4-12	Updated warnings, cautions and notes section to safety label section. Updated safety label format through out document. Added pin-out for connector to Section 1. Updated Cargo Hook with Cage parts list and figure.
9	08/05/10	4-9, 4-10	Replaced manual release knob P/N 290-580-01 with P/N 290-580-02.
10	10/06/10	4-5, 4-10	Added p/n 215-260-00 to overhaul kit.
11	10/11/10	1-3	Updated specifications table 1-1 to show carousel hooks may be used with 12 VDC systems and lowered electrical release capacity to reflect recent testing.
12	12/17/10	Section 1 & 4-13	Deleted selling kits 200-252-00, 200-252-01 & 200-252-02. Cargo Hooks now sold as 528-021-00, 528-021-01 & 210-242-00. Updated RMA information.
13	07/13/12	4-11 & 4-13	Replaced bolt P/N 510-810-00 with 510-953-00. For optimized length. Updated definition of “external load operations”.
14	09/10/12	Section 1 and Section 2	Added additional details and instructions for P/N 210-242-00 including Figure 1. Removed Functional Check before Installation section.
15	09/11/13	4-7 & 4-9	Updated Figure 4-1 and corrected qty. of 510-100-00.
16	09/09/15	1-4, 4-2, 4-5, 4-8 thru 4-10	Added diode to electrical release system.

### Register Your Products for Automatic Notifications

Onboard Systems offers a free notification service via fax or email for product alerts and documentation updates. By registering your Onboard Systems products at our website, we will be able to contact you if a service bulletin is issued, or if the documentation is updated.

You can choose to receive notices on an immediate, weekly, or monthly schedule via fax, email or both methods. There is no charge for this service. Please visit our website at [www.onboardsystems.com/notify.php](http://www.onboardsystems.com/notify.php) to get started.



This page intentionally left blank.

# ***CONTENTS***

## ***Section 1*** **General Information**

Introduction, 1-1  
Safety Labels, 1-2  
Inspection, 1-3  
Specifications, 1-3  
Pin Out, 1-4  
Theory of Operation, 1-4

## ***Section 2*** **Installation Instructions**

Cargo Hook Installation, 2-1  
Cargo Hook with Cage Configuration Installation, 2-2  
Post Installation Check-out, 2-3

## ***Section 3*** **Operation Instructions**

Cargo Hook Operating Procedures, 3-1  
Cargo Hook Rigging, 3-2

## ***Section 4*** **Maintenance**

Storage Instructions, 4-1  
Preventive Maintenance, 4-1  
Inspection, 4-1  
Trouble Shooting, 4-2  
Cargo Hook Overhaul Frequency, 4-2  
Cargo Hook Overhaul, 4-3  
Cargo Hook Disassembly Procedure, 4-3  
Cargo Hook Overhaul Inspection, 4-4  
Cargo Hook Assembly Procedures, 4-5  
Acceptance Test Procedures, 4-6  
Cargo Hook Reference Drawing, 4-7  
Cargo Hook Exploded View, 4-8  
Cargo Hook Parts, 4-9  
Cargo Hook w/ Cage Assembly Parts, 4-11  
Instructions for Returning a System to the Factory, 4-13

This page intentionally left blank.

# *Section 1*

## **General Information**

### **Introduction**

This manual provides installation, operation, and maintenance instructions for the following keeperless remote cargo hook configurations. These cargo hooks are suitable for carousel or other remote hook applications.

<b>Part No.</b>	<b>Description</b>
528-021-00	Cargo Hook – base configuration, primarily intended for use in a carousel or similar.
528-021-01	Cargo Hook – same as 528-021-00 except with brush guard to protect and prevent the manual release knob from being inadvertently actuated by branches, etc.
210-242-00	A P/N 528-021-01 Cargo Hook w/ protective welded cage, intended for use as a stand-alone remote cargo hook.



## Safety Labels

The following definitions apply to safety labels used in this manual.



Indicates a hazardous situation which, if not avoided, will result in death or serious injury.



Indicates a hazardous situation which, if not avoided, could result in death or serious injury.



Indicates a hazardous situation which, if not avoided, could result in minor or moderate injury.



Draws the reader's attention to important or unusual information not directly related to safety.



Used to address practices not related to personal injury.

## Inspection

Inspect the Cargo Hook for evidence of damage, corrosion and security of fasteners. If damage is evident, do not use the unit until it has been repaired.

## Specifications

**Table 1-1 Specifications**

Design load	2,000 lb. (907 kg.)
Design ultimate strength	9,000 lb. (4,082 kg.)
Electrical release capacity	5,000 lb. (2,268 kg.)
Knob torque required for release at 2,000 lb.	10 in-lb. max.
Electrical requirements <sup>†</sup>	12-14 VDC (~6 A) 22-28 VDC (~13 A)
Minimum release load	0 pounds
Unit weight (P/N 528-021-00)	5.7 pounds (2.6 kg.)
Unit weight (P/N 528-021-01)	6.0 pounds (2.7 kg.)
Unit weight (P/N 210-242-00)	16.2 lbs (7.3 kg.)

<sup>†</sup> Cargo Hook 528-021-00 or 528-021-01 may be used on either 14 VDC or 28 VDC aircraft—exact amperage depends on voltage. The cargo hook solenoid resistance is 2.2 ohms.

## Pin Out

Cargo Hooks with protective welded cage (P/N 210-242-00) are fitted with an electrical connector (Onboard Systems P/N 410-300-00). The pin-out below is applicable only to P/N 210-242-00.

**Table 1-2 Pin Out**

Wire Color	Screw Color	Function
Not Used	Green	Not Used
White	Silver	Neutral
Black	Brass	Power

## Theory of Operation

The primary elements of the Cargo Hook are the load beam, the internal mechanism, and a DC solenoid. The load beam supports the load and is latched through the internal mechanism. The DC solenoid and an external manual release knob provide the means for unlatching the load beam.

The load beam is normally held in the open position by a spring loaded detent. The load is attached to the load beam by passing the cargo load ring into the throat of the open load beam and pushing the ring against the upper portion of the load beam throat, which will close and latch the load beam. In the closed position, a latch engages the load beam and latches it in this position.

A load release can be initiated by two different methods. Normal release is achieved by pilot actuation of the DC solenoid. When the DC solenoid is energized, it opens the latch in the internal mechanism. A bi-directional diode provides transient voltage suppression for the solenoid.

The load can also be released by rotation of a manual release knob located on the side of the Cargo Hook.

With the latch disengaged, the weight of the load causes the load beam to swing to its open position and the load slides off the load beam. The load beam then remains in the open position awaiting the next load.

# *Section 2*

## **Installation Instructions**

### **Cargo Hook Installation**

Cargo Hook P/N 528-021-00 and 528-021-01 are intended for installation on a carousel or similar remote external load system.

Inspect the external load system to be used to ensure that all components are in serviceable condition before installing the Cargo Hook. Use two grade 8 or better 5/16 bolts of the appropriate length and locking type nuts to install the P/N 528-021-00 or 528-021-01 Cargo Hook on the structure of the external load system.

Connect the Cargo Hook electrical release cable to an electrical release cable from the aircraft's electrical release circuit. The connection of the two wires in the electrical release cable to the aircraft wiring is not polarity dependent. The cargo hook will function properly as long as the electrical release power circuit is completed.

Cargo Hooks with protective welded cage (P/N 210-242-00) (manufactured after July, 2010) are fitted with an electrical connector (Onboard Systems P/N 410-300-00). This connector is compatible with a Leviton P/N 5259-VY (Onboard Systems P/N 410-299-00). See Table 1-2 for connector pin-out.

## Cargo Hook with Cage Configuration (P/N 210-242-00) Installation

P/N 210-242-00 is intended for use as a stand-alone remote cargo hook. It can be attached directly to a long line thimble (shown below) or through an Onboard Systems 2K Electric Swivel (Kit P/N 200-386-00).

Attach the cage to a long line thimble by removing the cotter pin, nut, bolt and spool from the cage and inserting the spool within the thimble and re-installing it within the cage. An appropriately sized shackle or load ring can be also be used directly over the spool. Tighten the nut finger tight and then rotate to next castellation to install the cotter pin.

**Figure 2.1 Example Installation of 210-242-00**

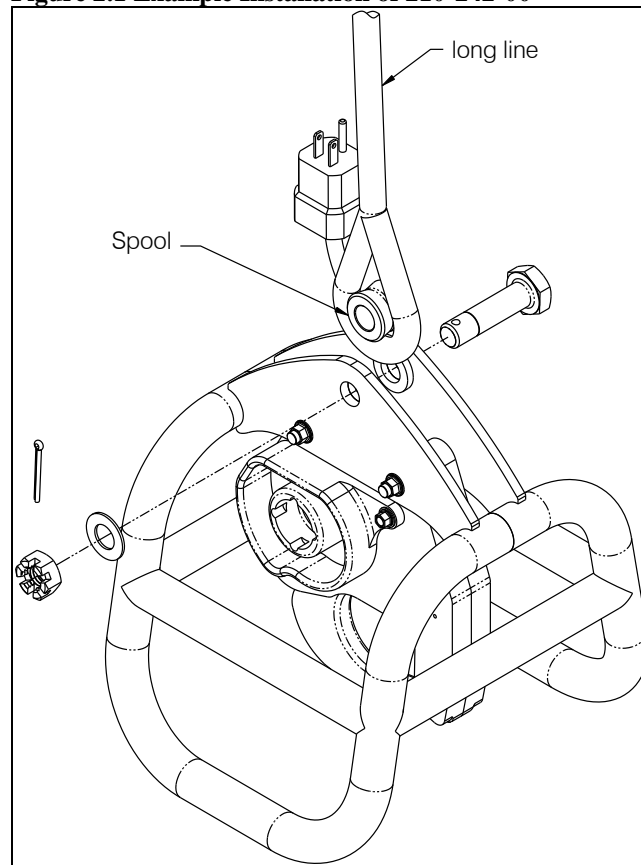

If installing the hook with the 2K electric swivel refer to Owner's Manual 120-209-00 for instructions.

### **NOTICE**

*To install the electric swivel within the cage it may be necessary to loosen the nuts on the bolts which attach the cargo hook to the cage plates. If the nuts are too tight they pull the cage plates inward causing the swivel lug to not fit within them. Loosen nuts just enough to fit swivel lug and allow it to rotate.*

## **Post Installation Check-Out**

After installation of the Cargo Hook, perform the following functional checks.

1. Ensure that the electrical release cable has enough slack to accommodate full movement of the cargo hook.
2. With the cargo hook load beam in the closed position energize the cargo hook electrical release circuit. The cargo hook load beam should release. Return the cargo hook load beam to the closed position
3. Turn the manual release knob in the clockwise direction, the Cargo Hook load beam should open.

This page intentionally left blank.

# Section 3

## Operation Instructions

### Cargo Hook Operating Procedures

Before operating the Cargo hook be completely familiar with the Rotorcraft Flight Manual Supplement for External Cargo Operation for your helicopter.

Cargo is released electrically by energizing the cargo hook electrical release circuit. The cargo hook may be returned to the closed and locked position by manually pushing up on the load beam. The load beam should snap shut. The cargo hook may be flown in the open position to facilitate loading by a ground crew.

#### CAUTION

*Continuous application of power to the Cargo Hook will cause the Cargo Hook solenoid to heat up. Permanent damage will occur if power is applied continuously for more than 20 seconds.*

For ground operations, the manual release knob can be rotated clockwise to release the cargo hook load beam. The cargo hook may be returned to the closed and locked position by manually pushing up on the load beam. The load beam should snap shut. The cargo hook may be flown in the open position to facilitate loading by a ground crew.

#### WARNING

*Icing conditions may cause the Cargo Hook to not release when commanded. It is not recommended to use the Cargo Hook in freezing conditions without adequate use of an anti-icing compound.*



## Cargo Hook Rigging

Extreme care must be exercised in rigging a load to the Cargo Hook. Steel load rings are recommended to provide consistent release performance and resistance to fouling.



*It is the responsibility of the operator to ensure the hook will function properly with each individual rigging configuration.*

If nylon straps or ropes are used, verify that they slide freely from the load beam when the cargo hook is opened. Extremely thin straps (less than a 1/16" thickness) may be capable of sliding off the tip of the loadbeam when latched.

When using steel load rings, verify that the ring will freely slide off the load beam when it is opened.

# Section 4

## Maintenance

### Storage Instructions

Clean the Cargo Hook components thoroughly before packaging. Pack the unit in a sealable package.

Place the sealed package in a suitable fiberboard box and cushion the unit to prevent shifting. Seal the fiberboard box with tape and mark the box with the contents and date of packaging.

If the unit is to be stored for long periods in a tropical climate it should be packed in a reliable manner to suit local conditions.

### Preventive Maintenance

Remove caked-on dirt from the Cargo Hook with a brush and clean exposed surfaces with a mild solvent. Thoroughly dry all surfaces.

### Inspection

The inspection of the Cargo Hook shall be in accordance with the table below.

Table 4-1 Inspection

Seq.	Part Number	Daily Check	Inspection - Annually or 100 hours of external load operations, whichever comes first.	Overhaul
1	528-021-00 528-021-01 Cargo Hook  210-242-00 Cargo Hook with Cage	<ol style="list-style-type: none"> <li>1. Inspect all fasteners to ensure that they are in place and secure.</li> <li>2. Visually inspect the electrical release cable and connection for damage.</li> <li>3. Inspect the cargo hook case and covers for cracks and damage.</li> <li>4. Inspect the load beam for gouges and cracks.</li> <li>5. Cycle the electrical release system and manual release knob to ensure proper operation.</li> </ol>	Same as Daily check.	See Cargo Hook Overhaul section of this manual.

# Trouble Shooting

Table 4-2 Trouble Shooting

DIFFICULTY	PROBABLE CAUSE	CORRECTIVE ACTION
Cargo hook does not operate electrically, manual release operates normally.	Open electrical circuit, faulty wiring, circuit breaker, switch or solenoid, shorted diode (if diode is present).	Disconnect electrical release cable connection from aircraft wiring. Using multimeter, check for 2.25 +/- .25 ohms between the two solenoid wires. If open indication is obtained, check the solenoid directly for 2.25 +/- .25 ohms resistance, replace solenoid if required. If 0 ohms, replace diode.
Cargo hook does not operate electrically or manually.	Defective internal mechanism	Disassemble, and inspect internal mechanism for binding, jamming, and worn or broken parts. Repair as necessary.
Cargo hook operates electrically, but not manually.  Load beam fails to relatch.	Defective manual release system Defective latch mechanism	Check manual release knob. Disassemble, and inspect internal mechanism for binding, jamming, and worn or broken parts. Repair as necessary.
Cargo hook manual release knob torque exceeds 10 in-lbs.	Defective manual release system.	Check manual release knob. Disassemble, and inspect internal mechanism for binding, jamming, and worn or broken parts. Repair as necessary.
Circuit breaker opens when Cargo Hook is energized.	Short in the system, faulty wiring, circuit breaker or solenoid	Check for shorts to ground. Check solenoid, repair or replace defective parts.

## Cargo Hook Overhaul Frequency

Time Between Overhaul (TBO): 1000 hours of external load operations or 5 years, whichever comes first.



*Hours of external load operations should be interpreted to be (1) anything is attached to the cargo hook (whether or not a useful load is being transported) and (2) the aircraft is flying. If these conditions are **NOT** met, time does **NOT** need to be tracked.*

## Cargo Hook Overhaul

It is recommended that only minor repairs be attempted by anyone other than the factory. It is recommended that the Cargo Hook be returned to the factory for overhaul or when any of the components are in need of major repair.

These procedures are provided for the benefit of experienced aircraft maintenance facilities capable of carrying out the procedures. They must not be attempted by those lacking the necessary expertise.

## Cargo Hook Disassembly Procedure

See Figure 4-2 for illustration and item numbers.

1. Remove the load beam bumper bolt (1), washers (2) and nut (3) from the solenoid cover.
2. Remove solenoid cover bolt (6.12) and washers (6.9). It is not necessary to remove the strain relief cover bolt (6.11) and washer (6.9) if you are only removing the solenoid assembly and not servicing the electrical release components.
3. Remove solenoid cover bolt (5) and washer (4).
4. If necessary remove strain relief cover (6.10) by removing bolts (6.11 and 6.12) and washers (6.9).
5. Remove solenoid assembly (6). Go to step 18 if solenoid assembly disassembly is required.
6. Remove nut (3) and washer (7) from inside the manual release knob, but do not remove the cam pivot bolt (8) at this time. The bolts should be left in place to hold the internal components aligned until the side plates are split.
7. Remove manual release knob (9), spacer (10) and wave washer (11).
8. Remove keeperless bolt (12), washers (2) and nut (3).
9. Remove load beam nut (13) and washer (14). Do not remove load beam bolt (15) and washer (14) at this time.
10. Remove nut (3) and washer (2) off of the toggle pivot bolt (12). Do not remove toggle pivot bolt (12) at this time.
11. Lift the manual release side plate (16) off of the bolts in the solenoid side plate. The toggle and cam assemblies are spring loaded so a light force may be required to split the side plates.
12. Remove load beam assembly (17) by moving cam assembly (18) clockwise and rotate toggle assembly (19) counter-clockwise to release the tip of the load beam. Hold the toggle and cam in this position while rotating the load beam. When load beam is in the fully open position, lift it out.
13. Slide the cam backup spring (18.1) off the roll pin (20) and lift cam assembly (21) out.
14. Remove the cam roller pin (21) from the toggle assembly (19).
15. Slide the toggle spring (19.2) off the roll pin (20) and lift the toggle assembly (19) out.
16. Remove the load beam bumper (22).
17. Bushings, bearings and roll pins may be removed from detail parts and assemblies by conventional means.

## Cargo Hook Disassembly Procedure continued

18. To disassemble the solenoid assembly (6) remove screws (6.1) and star washers (6.2) and striker (6.3).
19. Remove nuts (6.4) and washers (6.9).
20. Lift solenoid (6.5) and its wires out of solenoid cover (6.6) gently while pulling wires (6.7) through the strain relief hole.

## Cargo Hook Overhaul Inspection

Carefully inspect the detail parts in accordance with the instructions in Table 4-3. Inspect the parts in a clean, well lighted room. Inspect bearings and shafts for wear and corrosion. Pitting, corrosion or roller dents on shafts is cause for rejection. Max permissible bushing clearances are .004 on diameter.

Perform magnetic particle inspection in accordance with ASTM E1444 and MIL-STD-1907, Grade A on the parts listed below. No cracks are permitted in any of these parts.

Load beam (17.2)      Cam (18.6)

Perform penetrant inspection per ASTM E1417 and MIL-STD-1907, Grade A on the parts listed below. No cracks are permitted in any of these parts.

Side plate, manual (16)                      Side Plate, Solenoid (23.1)

Toggle (19.7)

**Table 4-3 Cargo Hook Overhaul Inspection**

<b>Part</b>	<b>Visually Inspect for</b>	<b>Remedy</b>
Threaded parts	Replace all threaded parts	Replace
Electrical Release Cable	Damaged cable and connectors	Replace
Nameplate	Mutilation or illegibility	Replace
Springs	Cracks and deformation	Replace
Bearings	Roughness, binding, looseness, or corrosion	Replace
Solenoid	Burning, check resistance with ohmmeter	Replace if burnt or if resistance is outside 2.25 +/- .25 ohm range
Bumpers	Wear or rubbing on load beam	Replace
Side plate assemblies and covers	Dents, nicks, cracks, gouges, or scratches	Repair minor, replace if otherwise damaged
Electrical wiring	Deterioration	Replace
Load beam	Gouges or burrs on wearing surfaces	Remove burrs, replace if gouged
Cam	Wear on cam surfaces and dents on bearing area	Replace

## Cargo Hook Assembly Procedures

See Figure 4-2 for illustration and item numbers.

1. Replace all parts found to be damaged with serviceable parts.
2. Install the cam pivot bolt (8) with no washer under the head, toggle pivot bolt (12) and washer (2) and load beam pivot bolt (15) into the solenoid side plate assembly (23).
3. Install the toggle assembly (19) and cam assembly (18) by nesting them in each other and placing the toggle assembly (19) over the toggle pivot bolt (12) and the cam assembly onto the cam pivot bolt (8).
4. Insert the cam roller pin (21) into the toggle assembly (19).
5. Slide the toggle spring (19.2) onto the center roll pin (20).
6. Slide the cam spring (18.1) onto the outer roll pin (20).
7. Move the cam by hand to release the toggle. Holding the cam in this position, insert the load beam assembly (17) onto the load beam pivot bolt (15)
8. Insert the load beam bumper (22) into the solenoid side plate assembly (23).
9. Place the manual side plate (16) onto the solenoid side plate assembly (23) and slide the manual slide plate over the protruding bolt ends.
10. Install and secure the toggle pivot bolt nut (3) and washer (2), torque nut to 20-25 in-lbs.
11. Install nut (3), washer (7), manual release knob (9), spacer (10) and wave washer (11) over the cam pivot bolt, torque nut to 30-40 in-lbs. Insert the manual release knob (9) striker into the slot in the side plate and place it behind the cam by reaching through the solenoid side plate slot and moving the cam clockwise. Secure nut (3).
12. Install and secure the load beam pivot bolt nut (13) and washer (14), torque nut to 20-25 in-lbs.
13. Install and secure the bumper bolt (12), washers (2) and nut (3), torque nut to 20-25 in-lbs.
14. If the solenoid assembly was removed from its housing, place the solenoid (6.5) and diode (6.13, included w/ S/N 1356 and subs.) into the solenoid housing (6.6) and place the wire (6.7) through the solenoid housing wire hole. If installing or replacing the diode use solder sleeves (6.14) and a heat gun to install it across the solenoid leads, it is not polarity sensitive.
15. Install washers (6.5) and nuts (6.9).
16. Install the striker (6.3) with the three star washers (6.2) and screws (6.1), using Loctite 262 on the screw threads.
17. Install the strain relief cover (6.10), washers (6.9), bolt (6.11), and bolt (6.12).
18. Install the solenoid assembly (6) onto the side plate with the three solenoid mounting bolts (1, 5, and 6.12) and washers (5, 2).
19. Perform Acceptance Test Procedures as listed in Section 4 of this manual.
20. Fill out and affix Overhaul Label (P/N 215-260-00).

## Acceptance Test Procedures

After the Cargo Hook has been repaired or stored for an extended period of time it must be subjected to the Acceptance Test Procedure as follows:

Examine the Cargo Hook externally for security of the fasteners.

Suspend the hook from a test rig capable of loading the Cargo Hook to 5,000 pounds. Use a steel ring or chain to apply the load to the load beam.

### **No Load Release Test**

Ensure that the cargo hook load beam is locked.

Rotate the manual release knob in the clockwise direction. The load beam should unlatch and fall open. Push the load beam closed and ensure that it is locked.

Connect an adjustable 22 - 28 VDC power supply with a momentary release switch wired into the electrical release circuit.

With 22 VDC supplied, press the release switch. The load beam should unlatch and fall open.

### **Proof Load Test**

Gradually load the Cargo Hook with the test rig to 5,000 pounds. Hold the load for 1 minute. The load beam should hold the load without unlatching. Reduce the load to zero.



*Do not release the proof test load electrically or manually. Decrease the load gradually after completion of the proof load test to prevent injury and/or damage to the Cargo Hook.*

### **Electrical load release test**

Apply a load using a steel ring or chain with a steel load ring that is free to drop clear of the load beam. Gradually load the Cargo Hook to 2,000 pounds and hold the load for 2 minutes.

With the power supply operating voltage set at 22 VDC, press the release button. The load beam should unlatch and the loading device should slide off the load beam. Push the load beam closed and ensure it is locked. Repeat the test a second time.

### **Manual load release test**

Gradually load the Cargo Hook to 2,000 pounds. Hold the load for 2 minutes. Perform a manual release by rotating the manual release knob clockwise. The required release torque shall not exceed 10 inch-pounds. Repeat the test a second time.

# Cargo Hook Reference Drawing

Figure 4-1 Cargo Hook Reference Drawing (P/N 528-021-00 shown)

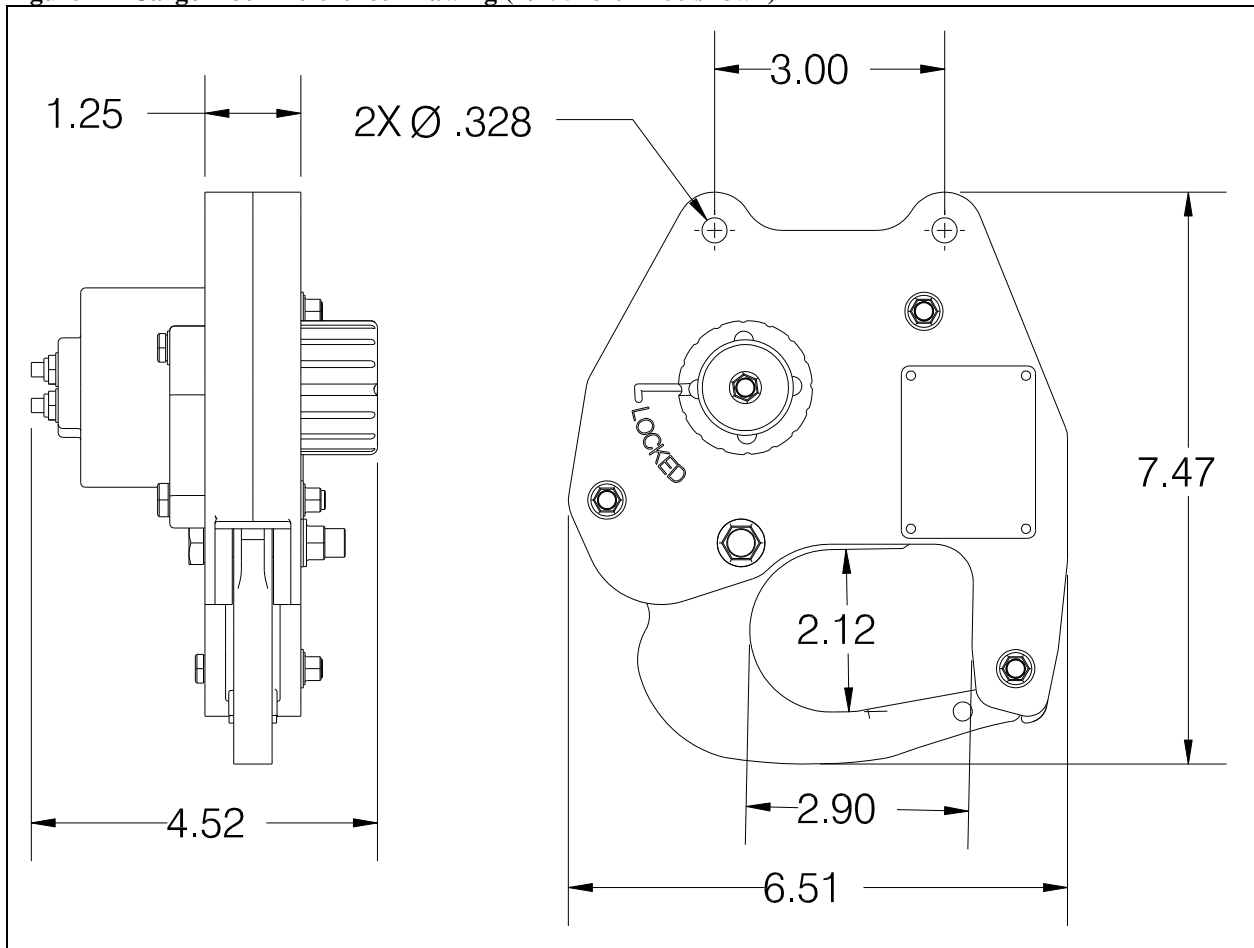



# Cargo Hook Exploded View

Figure 4-2 Cargo Hook Parts

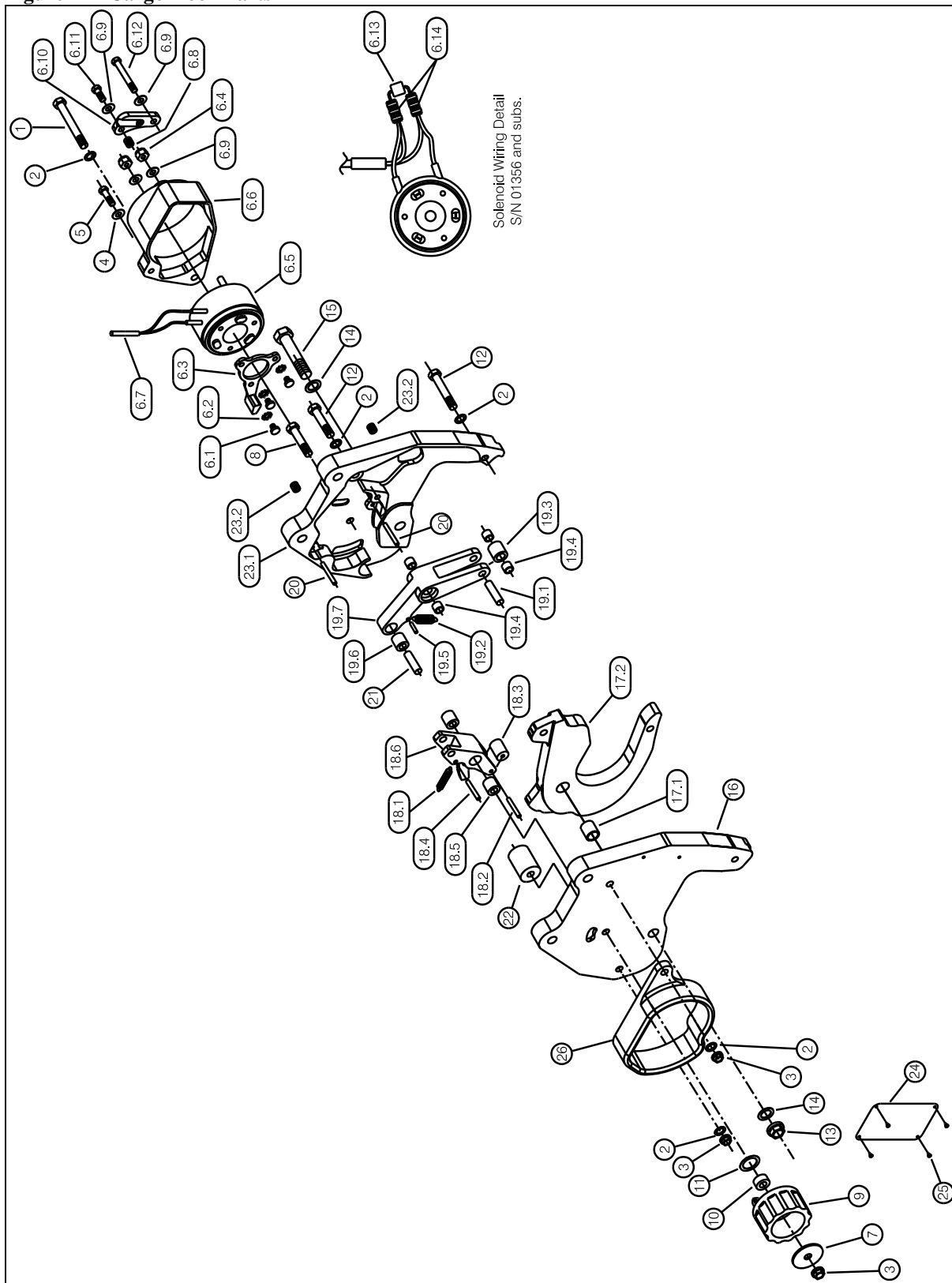

## Cargo Hook Parts

This section describes and lists the assemblies and detail parts of the Cargo Hook.

**Table 4-4 Cargo Hook (P/N 528-021-00, 528-021-01) Parts**

<i>Item</i>	<i>Part No.</i>	<i>Description</i>	<i>Qty</i>	<i>Qty included in Overhaul Kit P/N 212-021-00</i>
1	510-341-00	AN4-20A Bolt	1	1
	510-355-00 <sup>3</sup>	AN4-22A Bolt	1	1
2	510-100-00	AN960-416L Washer	3	3
3	510-114-00	MS21042-4 Nut	4	4
4	510-095-00	AN960-10L Washer	3	3
5	510-343-00	AN3-5A Bolt	1	1
6 <sup>1</sup>	232-092-00	Solenoid Assembly	1	-
6.1	510-148-00	#8-32 Screw	3	3
6.2	510-270-00	#8 Star Washer	3	3
6.3	290-578-00	Striker	1	-
6.4	510-043-00	AN365-1032A Nut	2	2
6.5	455-005-00	Solenoid	1	-
6.6	290-579-00	Solenoid Cover	1	-
6.7	420-058-00	18-2 Wire	1	-
6.8	510-248-00	3591-3CNY285 Helicoil	1	1
6.9	510-095-00	AN960-10L Washer	4	2
6.10	290-574-00	Strain Relief Cover	1	-
6.11	510-342-00	AN3-3A Bolt	1	1
6.12	510-344-00	AN3-13A Bolt	1	1
6.13 <sup>8</sup>	340-035-00	Diode	1	-
6.14 <sup>8</sup>	410-127-00	Solder Sleeve	1	-
7	510-336-00	AN970-4 Washer	1	1
8	510-322-00	NAS6604-23 Bolt	1	1
9	290-580-02 <sup>6</sup>	Manual Release Knob	1	-
10	510-327-00	Spacer	1	1
11	514-024-00	Wave Washer	1	1
12	510-339-00	AN4-14A Bolt	2	2
	510-786-00 <sup>4</sup>	AN4-16A Bolt	1	1
13	510-129-00	MS21042-6 Nut	1	1
14	510-238-00	NAS1149F0632P Washer	1	1
15	510-337-00	AN6-15A Bolt	1	1
16	290-577-00	Side Plate – Manual Release	1	-
17 <sup>1</sup>	232-087-00	Load Beam Assembly	1	-
17.1	517-016-00	Bearing – Load Beam Pivot	1	1
17.2	290-572-00	Load Beam	1	-
18 <sup>1</sup>	232-089-00	Cam Assembly	1	-
18.1	514-025-00	Cam Spring	1	1
18.2	290-584-00	Interlock Pin	1	-

**Table 4-4 Illustrated Parts Breakdown, continued**

<i>Figure</i>	<i>Part No.</i>	<i>Description</i>	<i>Qty</i>	<i>Qty included in Overhaul Kit P/N 212-021-00</i>
18.3	290-533-01	Interlock Roller	1	-
18.4	510-310-00	MS16562-225 Spring Rollpin	1	1
18.5	517-019-00	Cam Pivot Bearing	2	2
18.6	290-575-00	Cam	1	-
19 <sup>1</sup>	232-088-00	Toggle Assembly	1	-
19.1	290-440-00	Pin – Load Beam Roller	1	-
19.2	514-021-00	Spring	1	1
19.3 <sup>2</sup>	290-438-00	Load Beam Roller	1	-
19.4	517-021-00	Bearing – Toggle	4	2
19.5	510-331-00	MS16562-212 Roll Pin	1	-
19.6	517-019-00	Bearing – Cam Roller	1	1
19.7	290-573-00	Toggle	1	-
20	510-249-00	MS16562-226 Roll Pin	2	2
21	510-329-00	Pin - Cam Roller	1	-
22	514-017-00	Load Beam Bumper	1	1
23 <sup>1</sup>	232-090-00	Side Plate Assembly-Solenoid	1	-
23.1	290-576-00	Side Plate - Solenoid	1	-
23.2	510-248-00	3591-3CNY285 Helicoil	2	2
24	215-126-00	Serial Number Plate	1	-
25	510-262-00	Drive Screw	4	4
26 <sup>5</sup>	291-399-00	Brush Guard	1	-
27 <sup>7</sup>	215-260-00	Overhaul Label	-	1

**1** Items not illustrated as assemblies

**2** Optionally use P/N 510-330-00

**3** Bolt used on P/N 528-021-01 Cargo Hook only (in place of P/N 510-341-00).

**4** Bolt used on P/N 528-021-01 Cargo Hook only (at location through Brush Guard). Replaces one of P/N 510-339-00.

**5** Brush guard used on P/N 528-021-01 only.

**6** Optionally use P/N 290-580-01.

**7** Item not shown.

**8** Diode (with solder sleeves for assembly) included from the factory in cargo hook S/N 1356 and subsequent.

## Cargo Hook w/ Cage Assembly Parts

This section describes and lists the detail parts of the Cargo Hook with Cage.

Figure 4-3 Cargo Hook w/ Cage (P/N 210-242-00)

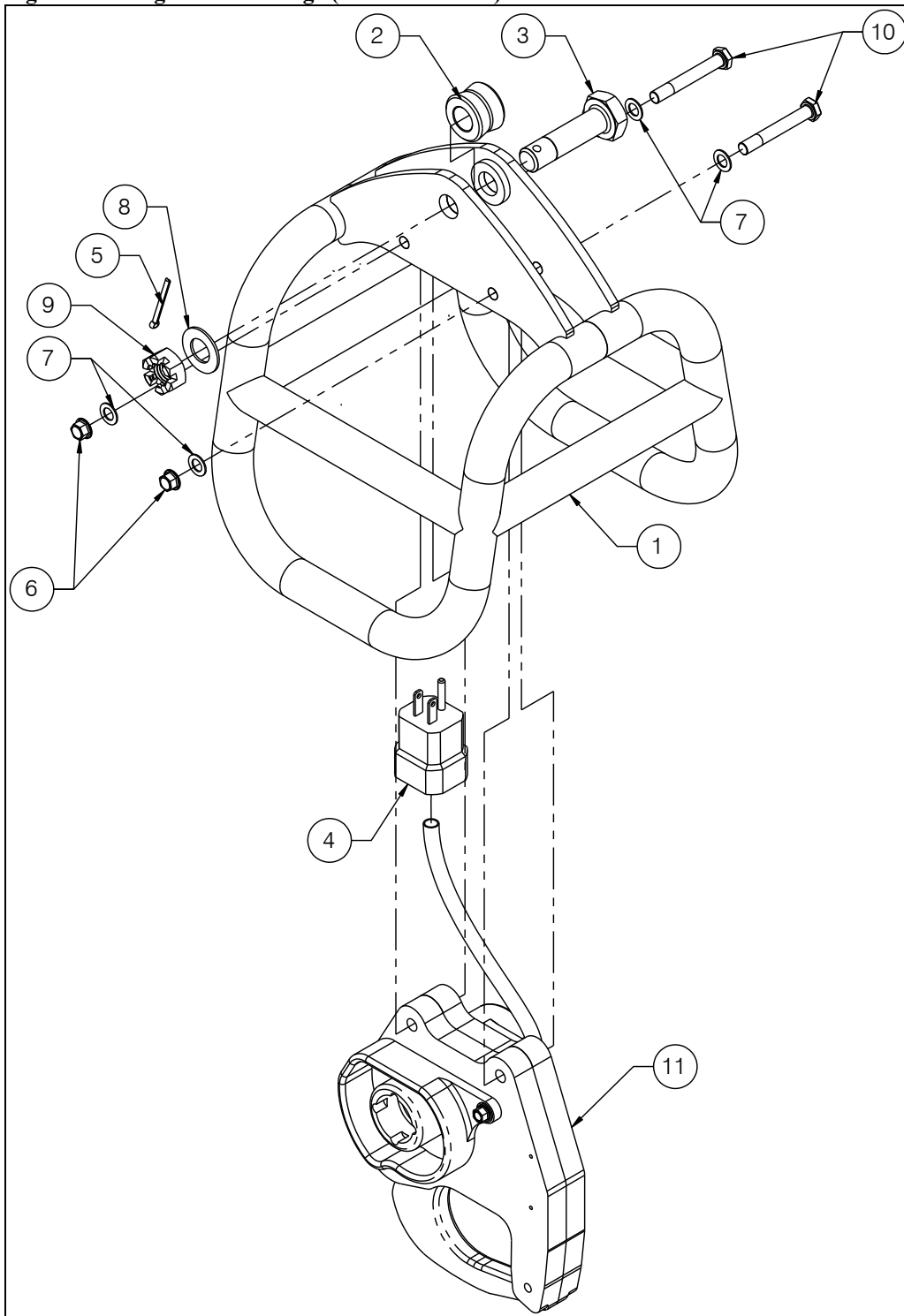

## Cargo Hook w/ Cage Assembly Parts continued

**Table 4-5 Cargo Hook w/ Cage Parts (P/N 210-242-00) Parts**

<i>Item</i>	<i>Part No.</i>	<i>Description</i>	<i>Qty</i>
1	235-179-00	2K LL Cage Weldment	1
2	291-475-00	Spool	1
3	291-537-00	Attach Bolt	1
4	410-300-00	Plug	1
5	510-098-00	Cotter Pin	1
6	510-104-00	Nut	2
7	510-239-00	Washer	4
8	510-303-00	Washer	1
9	510-933-00	Nut	1
10	510-953-00	Bolt	2
11	528-021-01*	Cargo Hook w/ Brush Guard	1

\* See Figure 4-2 and Table 4-4.

## Instructions for Returning Equipment to the Factory

If an Onboard Systems product must be returned to the factory for any reason (including returns, service, repairs, overhaul, etc) obtain an RMA number before shipping your return.



*An RMA number is required for all equipment returns.*

- To obtain an RMA, please use one of the listed methods.
  - Contact Technical Support by phone or e-mail ([Techhelp@OnboardSystems.com](mailto:Techhelp@OnboardSystems.com)).
  - Generate an RMA number at our website: <http://www.onboardsystems.com/rma.php>
- After you have obtained the RMA number, please be sure to:
  - Package the component carefully to ensure safe transit.
  - Write the RMA number on the outside of the box or on the mailing label.
  - Include the RMA number and reason for the return on your purchase or work order.
  - Include your name, address, phone and fax number and email (as applicable).
  - Return the components freight, cartage, insurance and customs prepaid to:

Onboard Systems  
13915 NW 3rd Court  
Vancouver, Washington 98685  
USA  
Phone: 360-546-3072