	Electronic Load Weigh System Trouble Shooting Guide	Document Number 125-001-00	Revision 2
		Date Effective June 5, 2013	Page 1 of 13

Electronic Load Weigh System Trouble Shooting Guide

Onboard Systems International
13915 NW 3rd Court
Vancouver, WA 98685 United States of America
Cage Code: 1Y921

Toll Free Phone: (800) 275-0883
Phone: (360) 546-3072
Fax: (360) 546-3073

Please check our web site www.onboardsystems.com for the latest revision of this guide.

	Electronic Load Weigh System Trouble Shooting Guide	Document Number 125-001-00	Revision 2
		Date Effective June 5, 2013	Page 2 of 13

1.0 Introduction

- 1.1 This guide outlines field trouble shooting procedures for Onboard Systems load weigh systems. It is intended as a guide for experienced aircraft mechanics using standard shop practices and basic troubleshooting skills.
- 1.2 The load weigh system consists of components that work together to form an operational system. They are the cockpit indicator, load cell and the interconnecting internal harness and optional equipment such as the analog meter and data recorder.
- 1.3 Initial troubleshooting is best done with the load weigh system installed in the helicopter. Standard shop tools and a quality volt-ohm meter will be required. Before starting, have available and be familiar with the current version of the owner's manual.
- 1.4 Difficulties with new system installations are usually associated with incorrectly setting up the cockpit indicator. Difficulties with the installation of new components i.e. replacement load cell or cockpit indicator are also due to cockpit indicator setup issues. Remember, it is always necessary to set the installation zero and the calibration code when changing either the load cell or the cockpit indicator. Refer to the owner's manual for the specific procedures.
- 1.5 Difficulties with existing installations are usually associated with cables that have been stretched, pinched or cut and connectors that are damaged or corroded.
- 1.6 Sections 2 through 9 outline the troubleshooting procedures and Section 10 is a symptoms and corrective action table. Section 11 contains information for returning an item to the factory for service.

2.0 System Arrangement

2.1 Figure 2.1 illustrates a typical installation arrangement, depicting the standard and the optional equipment.

Figure 2.1 Typical Load Weigh System Arrangement

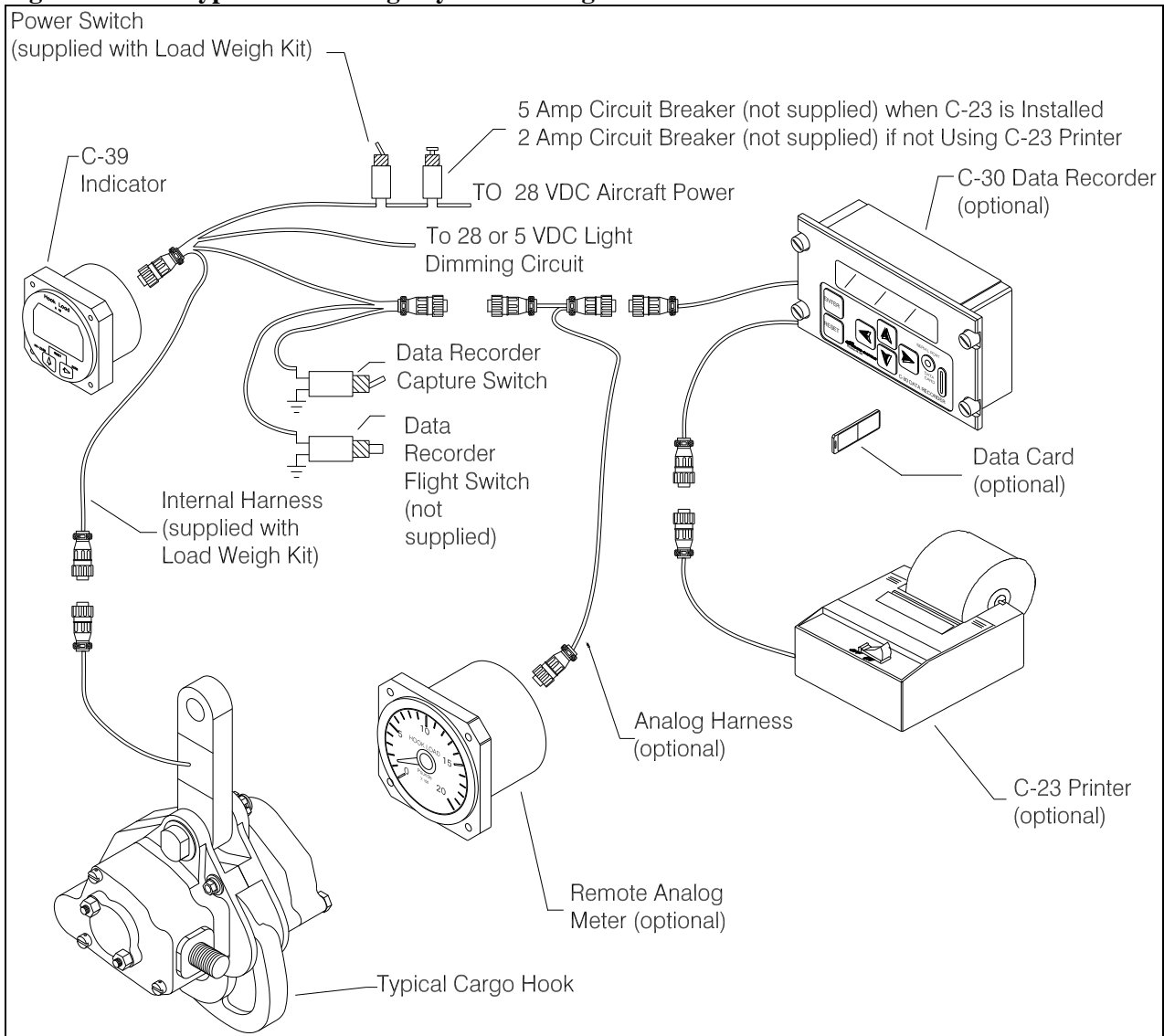

	Electronic Load Weigh System Trouble Shooting Guide	Document Number 125-001-00	Revision 2
		Date Effective June 5, 2013	Page 4 of 13

3.0 Cockpit Indicator

This section reviews the required system setup features. The C-39 cockpit indicator can be used with a wide range of helicopter and load cells as long as the installer correctly completes the setup process. This process matches the cockpit indicator to a specific load cell. This is done by entering data into the indicator such as the load cell's unique calibration code, the units that the indicator should read-out (pounds or kilograms) and installation zero. If a load cell has been replaced or serviced or the cockpit indicator has been changed, it is absolutely necessary that this data is entered.

3.1 Calibration Code

- 3.1.1 The calibration code, or cal code, is a mandatory input. The indicator will not accurately display the load without the correct calibration code. The calibration code scales the load cell signal.
- 3.1.2 If the indicator was supplied as part of a complete load weigh system, the factory may have entered the calibration code into the indicator, however, it should be confirmed. The load cell calibration code is located on a tag on the load cell or on the load cell cable.
- 3.1.3 If the indicator is to be mated to a different load cell, it must be calibrated before use. Calibration is done by entering the load cell's calibration code or by lifting a known load and having the cockpit indicator calibrate itself. Refer to the owner's manual for the procedures.

3.2 Installation Zero

- 3.2.1 The installation zero matches the load cell offset to the cockpit indicator. If the indicator was supplied as part of a complete load weigh system the installation zero will have been performed at the factory. If the load cell or the indicator has been replaced or serviced, the installation zero procedure must be repeated. If the installation zero procedure is not performed, the cockpit indicator readings will not be accurate. Refer to the owner's manual for the procedure.

3.3 Pound – Kilogram Setting

- 3.3.1 The cockpit indicator can be set by the user to display the load in pounds or kilograms. When powered up, the indicator displays a small LB or KG in the upper right side of the display window. To change the setting, refer to the owner's manual.

3.4 Self Calibration

- 3.4.1 Self-calibration or calibrating the system by lifting a known weight is a cockpit indicator routine that calculates the calibration code. This is useful if the load cell calibration code is not known or if the indicator is to be mated to a different load cell. The procedure is done by entering the known weight into the indicator and then lifting the weight. Refer to the owner's manual for the procedure.

3.5 Dampening Setting

- 3.5.1 The dampening setting is a cockpit indicator setting that stabilizes the indicator reading due to shaking or oscillations of the cargo hook load. It offers a trade-off between indicator stability and responsiveness. The settings allow the pilot to adjust the indicator to his flying conditions. Refer to the owner's manual to make the settings.

	Electronic Load Weigh System Trouble Shooting Guide	Document Number 125-001-00	Revision 2
		Date Effective June 5, 2013	Page 5 of 13

3.6 Error Messages

- 3.6.1 Each time the load weigh system is powered up the cockpit indicator goes through a self-diagnostic routine to check several internal components. If faults are found the instrument displays an error message. If an error message is displayed, power cycle the system; if the message returns send the indicator to the factory for service. (see Section 11.0).

3.7 Power Cycle

- 3.7.1 The cockpit indicator contains a microprocessor that continually executes instructions or code. Under unusual circumstances (low power, power interruptions of short duration and electrical noise) the processor can lose its place in the code. If the indicator exhibits unusual behavior it may be necessary to power cycle it; this restarts the processor to the beginning of its instructions. To power cycle the cockpit indicator, turn it off for a few moments and then turn it back on.
- 3.7.1.1 If this corrects the problem for a time but the problem returns check all of the power and ground connections to ensure that they are tight and free of corrosion.
- 3.7.1.2 If the problem occurs when a radio is keyed or some aircraft system is turned on or off (usually a relay), the problem is probably electrical noise. This problem can usually be corrected by separating the cables of the interfering systems that may be bundled together. Separating them by just a few inches is usually sufficient.

	Electronic Load Weigh System Trouble Shooting Guide	Document Number 125-001-00	Revision 2
		Date Effective June 5, 2013	Page 6 of 13

4.0 Internal Harness

- 4.1 Figure 4.1 is an illustration of the internal harness. Insure the system is wired as illustrated. Tables 4.2, 4.3 and 4.4 are the internal harness pin outs, which can be used to check for continuity and shorts to ground.
- 4.2 Visually inspect the electrical connections at the circuit breaker, power switch, cockpit indicator back light and the airframe ground. Ensure all connections are tight and corrosion free. Inspect the cockpit indicator and load cell connectors, ensure they are dry, corrosion free and in serviceable condition. Moisture and corrosion in the connectors are particularly detrimental. Ensure the cables are not being stretched, pinched or cut.
- 4.3 Use a voltmeter to check for aircraft voltage at the circuit breaker, power switch and the back light potentiometer. To ensure that the system ground is sound, the voltmeter ground probe should be the location where the internal harness is connected to airframe ground. If aircraft voltage is not present at the test points, take corrective action.

Figure 4.1 Wiring Arrangement

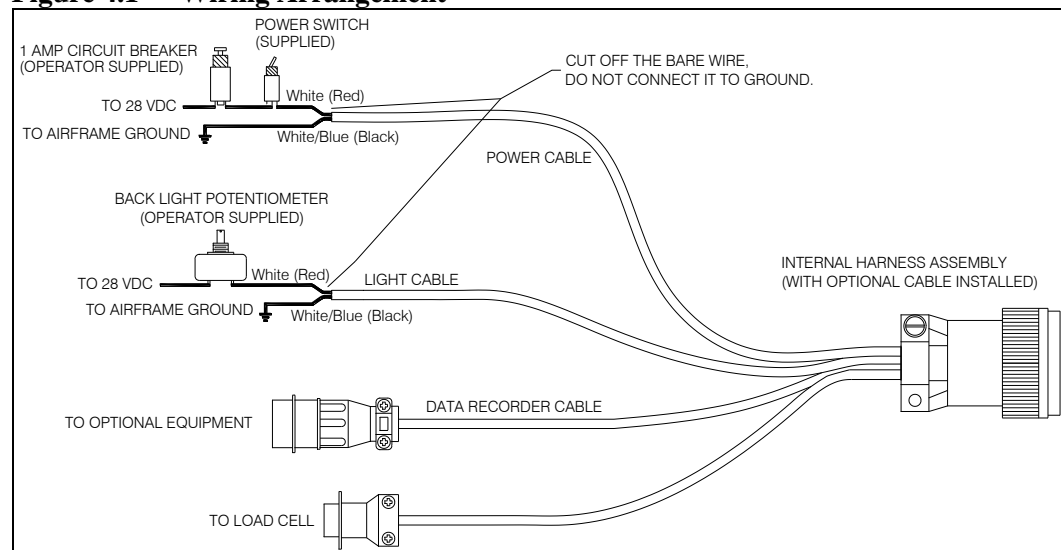

	Electronic Load Weigh System Trouble Shooting Guide	Document Number 125-001-00	Revision 2
		Date Effective June 5, 2013	Page 7 of 13

Table 4.2 Indicator Connector Pin Out

Pin	Color	Function	Cable
B	WH/OR (White)	-L/C Signal	Load Cell
C	WH/GN (Green)	+L/C Signal	
D	White (Red)	L/C Excitation	
E	WH/BLU (Black)	L/C Common	
L	Shield	Shield	
A	White (Red)	+ 28 Battery	Power
L	Shield	Shield	
P	WH/BLU (Black)	Ground	
A	White (Red)	Power	Data
J	WH/GN (Green)	Data Clock	
K	WH/OR (White)	Data Signal	
L	Shield	Shield	
P	WH/BLU (Black)	Ground	Light
M	WH/BLU (Black)	Light Common	
N	White (Clear)	Light Power	
L	Shield	Shield	
F	**	Analog Out Common	
G	**	Analog Out	

*Wire color may vary due to wire harness configuration.

**Optional customer supplied

Table 4.3 Data Connector Pin-out

Pin	Color	Function	Cable
1	WH/BLU (Black)	Ground	Data
3	White (Red)	Power	
5	Shield	Shield	
7	WH/GN (Green)	Data Clock	
9	WH/OR (White)	Data Signal	
4	Red	Flight	Switch
2	Purple	Capture	Switch

Table 4.4 Load Cell Connector Pin-out

Pin	Color	Function	Cable
A	White (Red)	+ Excitation	Load Cell
B	WH/GN (Green)	+ Signal	
C	WH/OR (White)	Signal	
D	WH/BLU (Black)	-Excitation	
E	Shield	Shield	

- 4.4 Check continuity and shorts to ground by first disconnecting the load cell and the cockpit indicator from the internal harness. Open the circuit breaker and the power switch (off position). For continuity tests, probe from one end of a wire to the other. For shorts to ground tests, probe from each pin and ground and probe between each pin and the other pins.

	Electronic Load Weigh System Trouble Shooting Guide	Document Number 125-001-00	Revision 2
		Date Effective June 5, 2013	Page 8 of 13

5.0 Load Cell and Cockpit Indicator Troubleshooting

Although there is no direct means to field troubleshoot the cockpit indicator and the load cell without specialized equipment, several options are available to isolate a troubled component. The two options listed below assume that the internal harness is operational. Be sure that the harness is serviceable before proceeding with these options (see Section 4).

- 5.1 Replace either the indicator or the load cell with a known serviceable unit (it is not important which component is replaced), almost any Onboard Systems indicator or load cell from any helicopter will work. If the component mates to the internal harness connector it should be adequate for troubleshooting purposes.
 - 5.1.1 If a serviceable cockpit indicator is to be substituted, plug it into the internal harness and power it up (Caution, if the back light voltage of the two indicators are not the same do not power up the back light circuit during this test). Press the zero button on the instrument, if the instrument displays zero have an assistant pull on the load cell, more than 10 pounds. If the indicator successfully displayed both the zero and a load reading (the actual load reading is not important it's just important that the load cell is sending a signal), it could be assumed that the load cell is operational and the original indicator is not. However if the indicator did not successfully display both the zero and the load reading, it could be assumed that the load cell is not operational. Send the suspect component to the factory for repair (see Section 11.0). Once the suspect component is replaced calibrate the system (see Section 3.1).
 - 5.1.2 If a serviceable load cell is to be substituted, it is not necessary to attach the load cell to the aircraft hard point or to the cargo hook. Plug it into the internal harness and power up the system. Press the zero button on the instrument, if the instrument displays zero have an assistant pull on the load cell, more than 10 pounds. If the indicator successfully displayed both the zero and the load readings, it could be assumed that the cockpit indicator is operational and the original load cell is not. However if the indicator did not successfully display both the zero and the load reading, it could be assumed that the cockpit indicator is not operational. Send the suspect component to the factory for repair (see Section 11.0). Once the suspect component is replaced calibrate the system (see Section 3.0).
- 5.2 A load cell substitution module is available from Onboard Systems, P/N 210-205-00. It is inserted in place of the load cell and sends two signals through the internal harness to the cockpit indicator. If the indicator displays the readings the load cell is in need of service. If the readings are not displayed the cockpit indicator is in need of service. The operation of the module is outlined below.
 - 5.2.1 With the load weigh system powered down disconnect the load cell from the internal harness and plug the module into the internal harness to load cell connector. Note: when the module is used on a 214 Bell, 330 and 332 Puma an adapter cable, P/N 270-109-00 is required to mate the module to the internal harness.
 - 5.2.2 Power up the load weigh system and note the cockpit indicator display. If load numbers are displayed move the test module toggle switch to its other position. If the system is operating normally the indicator should display high numbers with the module switch in one position and low numbers when the switch is in the other position. It is not yet important to know what the numbers are, it is only necessary to know that one module switch setting produces high numbers and the other produces low numbers. If high and low numbers are displayed go to step c. If high and low

	Electronic Load Weigh System Trouble Shooting Guide	Document Number 125-001-00	Revision 2
		Date Effective June 5, 2013	Page 9 of 13

numbers are not displayed the cockpit indicator is in need of service, assuming the internal harness has been checked out (see Section 4).

5.2.3 Move the test module toggle switch to the low number reading and press the cockpit indicator zero button. If the system is operating normally the indicator should now display zero \pm 3 digits. If zero is displayed go to step d. If zero is not displayed the cockpit indicator is in need of service, assuming the internal harness has been checked out (see Section 4).

5.2.4 Move the test module toggle switch to the high number reading. If the system is operating normally the correct number displayed is derived from the formula:

$$1,000,000 / \text{displayed number} = \text{calibration code} \pm 3\%$$

For example, if the calibration code is 500 the displayed number should be 2000 \pm 60 digits. If the correct number is displayed the cockpit indicator and the internal harness are operating correctly and it could be assumed that the load cell is in need of service.

5.2.5 There are no field serviceable items in the cockpit indicator or the load cell. If service is needed, send them to the factory (see Section 11.0).

6.0 Analog Meter

The optional analog meter receives a digital pulse stream from the cockpit indicator. The load weigh system must be completely functional before the analog meter will work correctly. If the load weigh system is functioning correctly but the analog meter is not check the following:

- 6.1 Check for a damaged cable between the cockpit indicator and the analog meter.
- 6.2 Check for damaged, corroded or wet connectors between the cockpit indicator and the analog meter.
- 6.3 There are no field serviceable items in the analog meter; return it to the factory for service (see Section 11.0).

7.0 Data Recorder

The optional data recorder receives a digital pulse stream from the cockpit indicator. The load weigh system must be completely functional before the data recorder will work correctly. If the load weigh system is functioning correctly but the data recorder is not check the following:

- 7.1 See the owner's manual for setup and operation instructions.
- 7.2 Check for a damaged cable between the cockpit indicator and the data recorder.
- 7.3 Check for damaged, corroded or wet connectors between the cockpit indicator and the data recorder.
- 7.4 There are no field serviceable items in the data recorder; return it to the factory for service (see Section 11.0).

	Electronic Load Weigh System Trouble Shooting Guide	Document Number 125-001-00	Revision 2
		Date Effective June 5, 2013	Page 10 of 13

8.0 C-23 Printer

The optional printer receives its signal from the data recorder. The load weigh system and the data recorder must be completely functional before the printer will work correctly. If the load weigh system and the data recorder are functioning correctly but the printer is not check the following:

- 8.1 See the owner's manual for operation instructions.
- 8.2 Check for a damaged cable between the data recorder and the printer.
- 8.3 Check for damaged, corroded or wet connectors between the data recorder and the printer.
- 8.4 There are no field serviceable items in the printer; return it to the factory for service (see Section 11.0).

9.0 Cable Repair

Each of the cables used in the load weigh system are made up of two or more insulated wires and usually a foil shield wrapped by a non-insulated drain wire. The shield provides a barrier to stray electrical energy (noise) and the drain wire drains this energy to ground. Note: to prevent ground loops the drain wire is attached to airframe ground at only one end of its length. The drain wire is terminated to ground through decoupling capacitors inside the cockpit instrument. The integrity of the shield system is critical to the satisfactory operation of the system. Therefore, it is generally not a good idea to attempt to repair a damaged cable. However, if a field repair must be made the following may be helpful in making a temporary repair.

- 9.1 Twist and solder all splices
- 9.2 Cover all splice with adhesive heat shrink
- 9.3 Maintain the integrity of the foil shield and the drain wire

	Electronic Load Weigh System Trouble Shooting Guide	Document Number 125-001-00	Revision 2
		Date Effective June 5, 2013	Page 11 of 13

10.0 Symptoms & Corrective Action

<i>SYMPTOM</i>	<i>CORRECTIVE ACTION</i>
When powered up the system appears dead, no characters are evident on the cockpit display	<ol style="list-style-type: none"> 1. Check the circuit breaker and the power switch (see Section 4) 2. Check the internal harness to see if it is correctly wired at the circuit breaker or power switch (see Section 4) 3. Check for a secure ground connection (see Section 4) 4. Check for power at internal harness connector pins A & P (see Section 4) 5. Return the cockpit indicator to the factory for service (see Section 11.0)
When powered up the circuit breaker opens immediately	<ol style="list-style-type: none"> 1. Check the circuit breaker and the power switch (see Section 4) 2. Check the internal harness to see if it is correctly wired at the circuit breaker or power switch (see Section 4) 3. Check the internal harness for shorts to ground (see Section 4) 4. Disconnect components one at a time to isolate possible cause.
The cockpit display appears frozen and the characters do not change with load	<ol style="list-style-type: none"> 1. Power cycle the circuit breaker or power switch (see Section 4) 2. Check the calibration code (see Section 3.1) 3. Check the internal harness (see Section 4) 4. Check the load cell (see Section 5)
Unable to zero the cockpit indicator with no load on the cargo hook	<ol style="list-style-type: none"> 1. Power cycle the circuit breaker or power switch (see Section 4) 2. Check the internal harness and load cell for opens & out of tolerance resistance (see Section 4) 3. Check the load cell (see Section 5)
With a load on the cargo hook the cockpit indicator load reading is high or low	<ol style="list-style-type: none"> 1. Verify that the calibration code is correct (see Section 3.1) 2. Verify that the pound/kilogram setting is correct (see Section 3.3) 3. Run the self-calibration procedure (see Section 3.4) 4. Check internal harness, especially moisture / corrosion. (see Section 4)
The cockpit display fluctuates with load	<ol style="list-style-type: none"> 1. Power cycle the circuit breaker or power switch (see Section 3.7) 2. Check the cockpit indicator dampening setting (see Section 3.5)
The cockpit display hunts up and down or fluctuates erratically with or without a load	<ol style="list-style-type: none"> 1. Power cycle the circuit breaker or power switch (see Section 3.7) 2. Check the internal harness, cockpit indicator and load cell (see Section 4 & 5)
Error messages are displayed on the cockpit display	<ol style="list-style-type: none"> 1. Power cycle the circuit breaker or power switch (see Section 3.7) 2. Read about error messages (see Section 3.6) 3. Return the cockpit indicator to the factory for service (see Section 11.0)
The cockpit display buttons do not respond	<ol style="list-style-type: none"> 1. Power cycle the circuit breaker or power switch (see Section 3.7) 2. Return the cockpit indicator to the factory for service (see Section 11.0)



**Electronic Load Weigh System
Trouble Shooting Guide**

Document Number
125-001-00

Revision
2

Date Effective
June 5, 2013

Page
12 of 13

<i>SYMPTOM</i>	<i>CORRECTIVE ACTION</i>
The cockpit display back light does not illuminate	<ol style="list-style-type: none"> 1. Check the internal harness connector pins N & M for power (see Section 4) 2. Return the cockpit indicator to the factory for service (see Section 11.0)
The cockpit display has missing characters	<ol style="list-style-type: none"> 1. Power cycle the circuit breaker or power switch (see Section 3.7) 2. Return the cockpit indicator to the factory for service (see Section 11.0)
The cockpit display digits appear to be melting together or bleeding.	The cockpit indicator has been exposed to temperature extremes beyond its limits. Return the cockpit indicator to the factory for service (see Section 11.0)
The cockpit display has moisture inside	Return the cockpit indicator to the factory for service (see Section 11.0)
The internal harness is damaged	<ol style="list-style-type: none"> 1. Read about cable repair (see Section 9) 2. Replace the internal harness
The load cell cable is damaged	Return the load cell to the factory for service (see Section 11.0)
The load cell lifting eyes and or bushings are worn.	<ol style="list-style-type: none"> 1. Refer to the owners manual for wear limits and replace components as necessary 2. Return the load cell to the factory for service (see Section 11.0)
The analog meter is not working correctly	Read about the analog meter (see Section 6.0)
The data recorder is not working correctly	Read about the data recorder (see Section 7.0)
The printer is not working correctly	Read about the printer (see Section 8.0)

	Electronic Load Weigh System Trouble Shooting Guide	Document Number 125-001-00	Revision 2
		Date Effective June 5, 2013	Page 13 of 13

11.0 Instructions for Returning Equipment to the Factory

- 11.1 If an Onboard Systems product must be returned to the factory for any reason (including returns, service, repairs, overhaul, etc.), please contact Technical Support by phone or email to obtain an RMA number before returning it. For more information, please refer to our website.



A RMA number is required for all equipment returns.

- After you have obtained the RMA number, please be sure to:
- Package the component carefully to ensure safe transit
- Write the RMA number on the outside of the box or on the mailing label
- Include the RMA number and reason for the return on your purchase or work order
- Include your name, address, phone and fax number and email (as applicable)
- Return the components freight, cartage, insurance and customs prepaid to:

Onboard Systems
13915 NW 3rd Court
Vancouver, Washington 98685
USA

Phone: 360-546-3072
Fax (360) 546-3073
E-mail Support@OnboardSystems.com