

**PLEASE CHECK WEB SITE AT WWW.ONBOARDSYSTEMS.COM FOR
THE LATEST REVISION OF THIS MANUAL**

**FAA APPROVED
ROTORCRAFT FLIGHT MANUAL
SUPPLEMENT**

***Onboard Systems
Cargo Hook Swing Suspension System***

***Airbus Helicopter Models
AS350B, AS350B1, AS350B2, AS350B3
AS350BA, & AS350D***

R/N _____ S/N _____

FAA Approved: 
Manager, Seattle Aircraft Certification Office
Federal Aviation Administration
Renton, Washington

Date:
Revised: JUL 31 2015

	RFM Supplement	Document Number 121-012-03	
	Cargo Swing	Page 1 of 15	Revision 1

Record of Revisions

Rev.	Date	Page(s)	Reason for Revision
0	03/04/2010	All	Initial Release
1	07/31/2015	All	Re-format and re-write of manual.

	RFM Supplement	Document Number 121-012-03	Rev. 1
	Cargo Swing	Page 2 of 15	FAA Approved JUL 31 2015

1 GENERAL

This supplement must be attached to the appropriate FAA approved Airbus Helicopters Rotorcraft Flight Manual when an Onboard Systems 200-280-04 Cargo Hook Swing Suspension is installed in accordance with Supplemental Type Certificate (STC) NO. SR01164SE. In addition it is necessary to obtain Airbus Helicopters' EXTERNAL LOAD TRANSPORT "CARGO SWING" Flight Manual Supplement for your particular AS350 model helicopter.

The information contained herein supplements or supersedes the basic manual only in those areas listed herein. For limitations, procedures and performance information not contained in this supplement consult the basic Rotorcraft Flight Manual and the "Cargo Swing" Flight Manual Supplement issued by Airbus Helicopters.

The 200-280-04 Cargo Hook Swing Suspension System is comprised of:

- A suspended pyramid frame that supports the cargo hook and is designed to reduce swinging of the load.
- An electrical release system that provides means for release by pilot arming of the system with the SLING push button on the console and actuating the release switch on the cyclic. These STC systems interface with the Airbus supplied push button on the console and switch on the cyclic.
- A manual release system, which provides an additional means of releasing a cargo hook load. A lever mounted to the collective actuates it.
- A load weigh system, which is comprised of an indicator mounted to the RH door pillar within the cockpit and a load cell at the cargo hook.



RFM Supplement

Document Number
121-012-03

Rev. 1

Cargo Swing

Page
3 of 15

FAA Approved
JUL 31 2015

2 LIMITATIONS

The limitations specified in the basic flight manual and the Airbus Helicopters' "Cargo Swing" flight manual supplement remain applicable and are completed or modified by the following.

Operating Limitations

With a load attached to the cargo hook, operation shall be conducted in accordance with the respective national operational requirements. For US operators 14 CFR part 133 is applicable.

The cargo hook kit configurations (as installed per this STC SR01164SE) do not meet the 14 CFR part 27 certification requirements for Human External Cargo (HEC).

NOTICE

The cargo hook kit equipment certification approval does not constitute operational approval; operational approval for external load operations must be granted by the local Aviation Authority.

! WARNING

The swing suspension is designed to allow the cargo hook to pivot and align with the external load in all directions with limits to protect the electrical and mechanical release cables from damage. Take precautions to prevent external load angles which exceed the limits of rotation provided by the suspension as the load may not be releasable in this position.



RFM Supplement

Document Number
121-012-03

Rev. 1

Cargo Swing

Page
4 of 15

FAA Approved
JUL 31 2015

Cargo hook maximum load

The maximum load to be carried on the cargo swing is the lesser of that specified by the Airbus Helicopters' Cargo Swing Flight Manual Supplement or 3086 lbs (1400 kg).

Placards

The following placards are included with the 200-280-04 Cargo Hook Swing Suspension System.

Mounted near to the cargo hook and in clear view of ground crew:

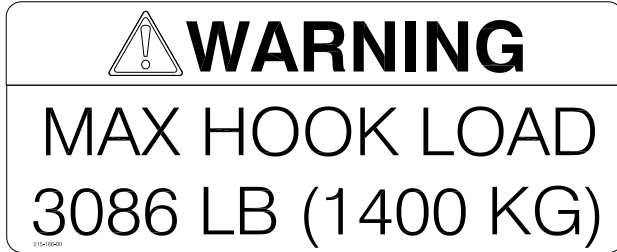

Adhered on the underside of the cargo hook electrical housing:

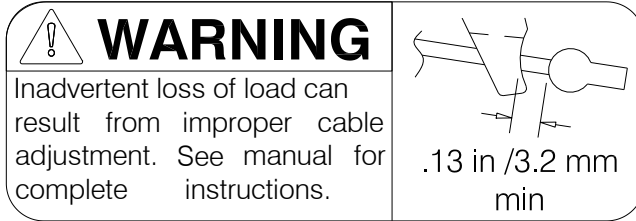

Attached around the manual release cable:

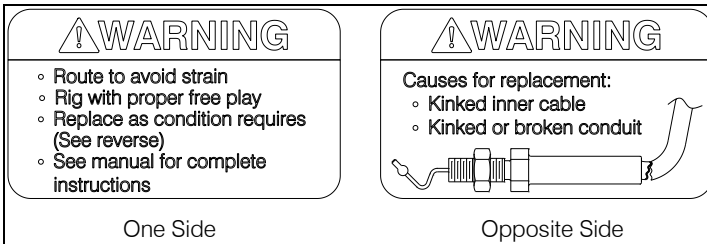

RFM Supplement

Document Number
121-012-03

Rev. 1

Cargo Swing

Page
5 of 15

FAA Approved
JUL 31 2015

3 **EMERGENCY PROCEDURES**

In the event of engine failure in flight while transporting external load:

1. Establish auto-rotational flight.
2. Release external load immediately.

In the event of engine failure while ground crew is attaching the external load:

1. Move the rotorcraft to the right.
2. Ground crew is to be instructed to move to the left of the rotorcraft.

In the event that the cargo hook fails to release electrically proceed as follows:

1. Maintain tension on the long line.
2. Pull the mechanical release lever on the collective to release the external load.

	RFM Supplement	Document Number 121-012-03	Rev. 1
	Cargo Swing	Page 6 of 15	FAA Approved JUL 31 2015

4 NORMAL PROCEDURES

The normal procedures specified in the basic flight manual remain applicable and are complemented by the following.

Pre-Flight Check

Before a flight involving external load operations perform the following procedures. If the procedures are not successful do not use the equipment until the problem has been corrected.

1. Check all mounting fasteners to ensure that they are secure.
2. Check the electrical connectors for damage and security.
3. Check the cargo hook exterior and suspension for cracks and damage.
4. Check the cargo hook load beam for gouges and cracks.
5. Swing the hook and the suspension assembly to their full extremes to verify that they do not reach the limit of the mechanical release cable and electrical harness range of motions.



RFM Supplement

Document Number

121-012-03

Rev. 1

Cargo Swing

Page
7 of 15

FAA Approved
JUL 31 2015

Pre-Flight Check continued

6. Cycle the cargo hook's electrical release mechanism to ensure proper operation. Pressing the CARGO RELEASE switch on cyclic should cause the cargo hook load beam to open. The cargo hook may be returned to the locked position by manually pushing up on the load beam. The load beam should snap shut. The cargo hook may be flown in the open position to facilitate loading by a ground crew.
7. Cycle the manual release mechanism to ensure proper operation. Pull the manual release lever in the cockpit. The cargo hook load beam must open. Return the cargo hook load beam to the locked position by manually pushing up on it. The load beam should snap shut. Verify that the hook lock indicator on the side of the hook returns to the fully locked position.



In the closed and fully locked position the hook lock indicator must align with the lines on the manual release cover (see Figure 1).

Figure 1 Hook Lock Indicator

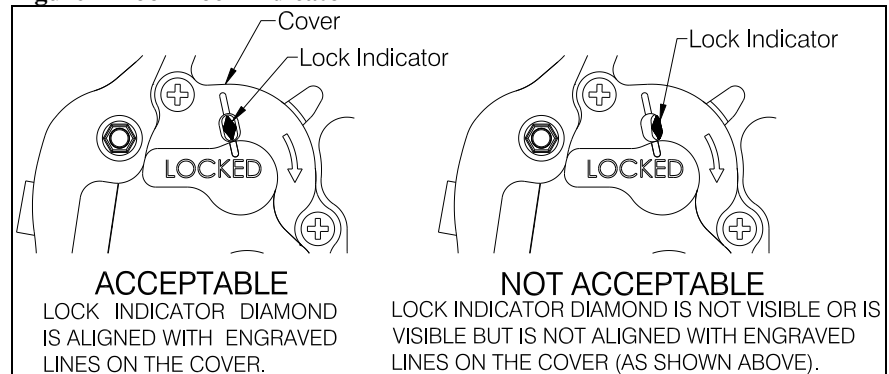

	RFM Supplement	Document Number 121-012-03	Rev. 1
	Cargo Swing	Page 8 of 15	FAA Approved JUL 31 2015

Pre-Flight Check continued

8. Check the manual release cable rigging through the window in the cargo hook manual release cover. With the cargo hook closed and locked, rotate the manual release lever clockwise to remove the free play (the free play is taken up when the hook lock indicator begins to move, this is also readily felt as the lever rotates relatively easily for several degrees as the free play is taken up) and hold it in this position while checking the gap between the release lever fork and the cable ball end as shown below. Visually check that there is approximately a minimum gap of 1/8" (3.2 mm) as shown in Figure 2.

Figure 2 Manual Release Cable Rigging

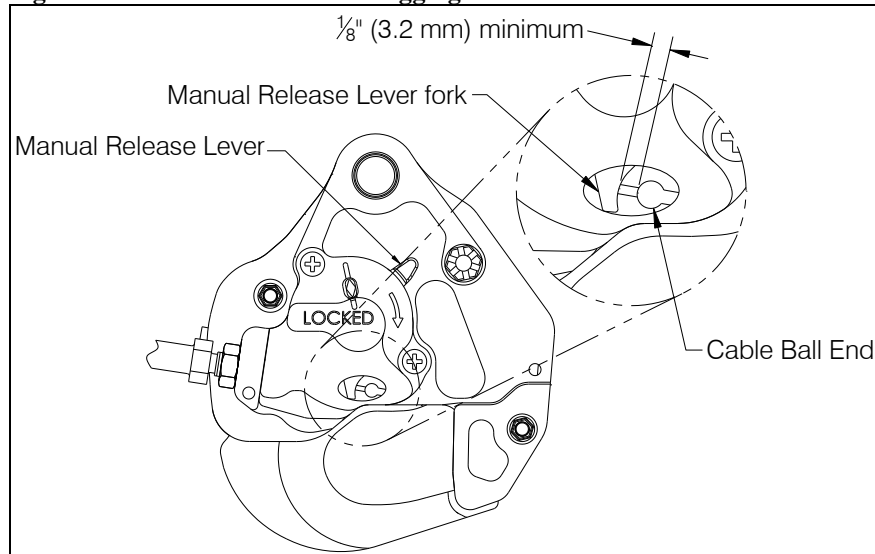

Pre-Flight Check continued

9. Power on the hook Load Indicator and allow it to warm up for 5 minutes (with no load on the hook). Press both Indicator buttons at the same time to go to the setup mode. Scroll through the menu until the symbol "0 in" (see Figure 3) is displayed, then press the right button. Remove any weight that is not to be zeroed out and press either button to complete the procedure.

Figure 3 C-39 Indicator "0 in" Screen

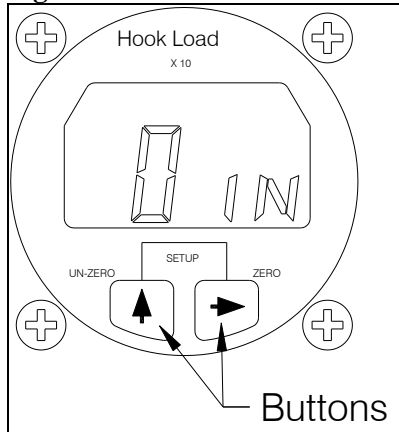

	RFM Supplement	Document Number 121-012-03	Rev. 1
	Cargo Swing	Page 10 of 15	FAA Approved JUL 31 2015

Cargo Hook Rigging

Prior to attaching an external load, instruct the ground crew to ensure that the helicopter has been electrically grounded to discharge static electricity. If possible, maintain ground contact until hook up is completed.

Extreme care must be exercised in rigging a load to the Cargo Hook. The following illustration shows the recommended rigging configuration and rigging to avoid.



The examples shown are not intended to represent all possibilities. It is the responsibility of the operator to ensure the hook will function properly with the rigging. Some combinations of small primary rings and large secondary rings could cause fouling during release.



Nylon type straps (or similar material) or rope must not be used directly on the cargo hook load beam. If nylon straps or rope must be used they should be first attached to a steel primary ring. Verify that the ring will freely slide off the load beam when it is opened. Only the primary ring should be in contact with the cargo hook load beam. See Figure 4.

Cargo Hook Rigging continued

Figure 4 Examples of Cargo Hook Rigging

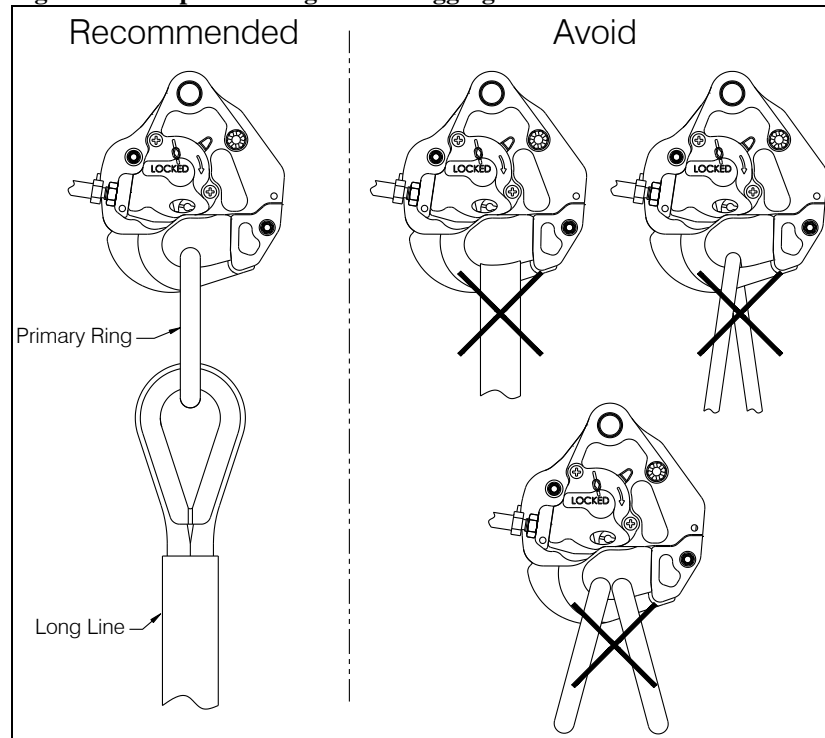

RFM Supplement

Cargo Swing

Document Number
121-012-03

Rev. 1

Page
12 of 15

FAA Approved
JUL 31 2015

Take-off

1. Following attachment of the external load, slowly increase the collective pitch and ascend vertically, maintaining the rotorcraft directly above the load.
2. When the slack in the long line is removed dwell briefly before lifting the load vertically from the surface.
3. Check torque required to hover with the external load.
4. Check for adequate directional control.
5. Take off into the wind, if possible, and ensure clearance of the external load over obstacles.

Maneuvers

Make all control movements gently with gradual acceleration and deceleration and only slightly banked turns.



Control movements should be made gently and kept to a minimum to prevent oscillation of the load and to maintain the external load angle within the limits of rotation of the cargo hook.



RFM Supplement

Document Number
121-012-03

Rev. 1

Cargo Swing

Page
13 of 15

FAA Approved
JUL 31 2015

Approach and Release of External Load

1. Perform the approach at minimum rate of descent.
2. Execute the approach to hover with sufficient height to prevent the load from hitting obstacles on or being dragged along the ground and then slowly descend vertically to set the load on the ground.
3. Press the CARGO RELEASE switch on the cyclic to release the external load from the cargo hook.

The manual release lever on the collective is intended as a backup release in the event of an inability to release the load with the CARGO RELEASE switch but may be used to release the external load in normal circumstances.

4. Visually check to ensure that the external load has been released.



Verify that the external load and long line has dropped free from the rotorcraft before departing the drop-site.

	RFM Supplement	Document Number 121-012-03	Rev. 1
	Cargo Swing	Page 14 of 15	FAA Approved JUL 31 2015

5 PERFORMANCE

The basic Flight Manual and “Cargo Swing” Flight Manual Supplement issued by Airbus Helicopters remain applicable.

When there is an external load, performance will be reduced depending on its size, weight and shape.

The Load Weigh System is designed and installed as a means of MONITORING the load (weight) suspended from the Cargo Hook. Functional and performance characteristics have not been determined on the basis of Load Cell indication or display. Therefore, this instrument shall NOT be used as a primary indication of performance and flight operation must NOT be predicated on its use.



RFM Supplement

Document Number

121-012-03

Rev. 1

Cargo Swing

Page
15 of 15

FAA Approved
JUL 31 2015