	Owner's Manual Airbus Helicopters Common Beam EC145T2	Document Number 120-217-00	Revision 8
		Date 07/15/21	Page 1 of 48

Owner's Manual

Hydraulic Cargo Hook Kit

Airbus Helicopters

Common Beam

EC145T2

Onboard Systems International
13915 NW 3rd Court
Vancouver, WA 98685 United States of America
Cage Code: 1Y921

Toll Free Phone: (800) 275-0883
Phone: (360) 546-3072
Fax: (360) 546-3073

Applicable Equipment Part Numbers

232-626-10
232-626-11
232-637-00
232-638-00
232-639-00

	Owner's Manual Airbus Helicopters Common Beam EC145T2	Document Number 120-217-00	Revision 8
		Date 07/15/21	Page 2 of 48

RECORD OF REVISIONS

Revision Number	Date	Revised Page	Description of Change
0	02/24/2014	All	New Issue
1	03/14/2014	7, 13, 14, 22	Corrected call outs of hooks 1 & 2 Added figure of bleed kit. Added torque value to shoulder screws. Added note for line routing. Added reference to new slave cylinder bleeding. Added figure showing connection of bleed kit. Added instructions for slave cylinder bleed operation.
2	6/10/2014	6, 13, 20, 32	Changed bleed kit from 212-014-00 to 212-014-01. Corrected bleed instructions.
3	08/13/2014	1,9,12,13,30	Added maintenance instructions for master cylinder, plumbing, and slave cylinder. Added approx. weight to table 4.2. Added instructions for bleeding w/o cargo hook(s). Removed web site references.
4	08/20/2014	6, 9, 13, 30, 44	Updated CMM p/n from 122-015-00 to 122-030-00. Changed 528-028-00 to 258-028-55. "6-32" changed to (291-853-00).
5	12/10/2014	39, 41	O-Ring p/n changed from 556-044-00 to 556-105-00. Shoulder Screw p/n changed from 291-853-00 to 511-124-00 due to FRACAS 106.
6	07/08/2015	1, 39, 41	Deleted EC135 from title and references in document. O-Ring P/N changed from 556-042-00 to 556-047-00. Dowel pin on single master cylinder changed from 511-086-00 to 511-085-00. Corrected callout of ball spring plunger to 14 on Figure 8.4. Changed spring plunger from 511-084-00 to 511-109-00.
7	09/08/2017	6, 13, 22-24	Updated Bleed Kit P/Ns and reworded bleeding instructions to add recommended MIL-PRF-87257 kits.
8	07/15/21	7, 32, 38, 39, 46	Updated Cargo Hook CMM document number from 122-030-00 to 122-015-00. Listed alternate banjo bolt P/N 291-665-01 and associated Service Bulletin 159-048-00.

	Owner's Manual Airbus Helicopters Common Beam EC145T2	Document Number 120-217-00	Revision 8
		Date 07/15/21	Page 3 of 48

TABLE OF CONTENTS

1.0	Introduction	6
1.1	Scope	6
1.2	Capability	6
1.3	Safety Labels	6
2.0	Referenced Documents	7
3.0	Special Tools	7
4.0	System Overview	7
4.1	Description/Theory of Operation	7
4.2	Specifications	10
4.3	Bill of Materials	11
4.3.1	Single Cargo Hook System - EC145T2	11
4.3.2	Dual Cargo Hook System - EC145T2	11
5.0	Installation Instructions	12
5.1	Install Cargo Hooks and Hydraulic Lines	12
5.2	Fill and Bleed Hydraulic System – Initial Installation	14
5.3	Install Master Cylinder Assemblies	18
5.4	Hydraulic System Operation Check	23
5.5	Slave Cylinder Bleeding Instructions	24
5.6	Electrical Release	26
5.7	Installation Check-out	27
6.0	Operation Instructions	28
6.1	Pre-Flight Check	28
6.2	Cargo Hook Loading	29
6.3	Cargo Hook Rigging	30
7.0	Maintenance and Inspection	32
7.1	Cargo Hook	32
7.2	Master Cylinder	32
7.2.1	Maintenance	32
7.2.2	100 hour/Annual Inspection	32
7.3	Intermediate Plumbing Assemblies	32
7.3.1	Maintenance	32
7.3.2	100 hour/ Annual Inspection	32
7.4	Slave Cylinder Assembly	32
7.4.1	Maintenance	32
7.4.2	100 hour/Annual Inspection	32
7.5	Instructions for Returning Equipment to the Factory	33
7.6	Lockout Adjustment	34
8.0	Illustrated Parts List	36

	Owner's Manual Airbus Helicopters Common Beam EC145T2	Document Number 120-217-00	Revision 8
		Date 07/15/21	Page 4 of 48

TABLE OF TABLES

Table 4.1 Specifications - P/N 528-028-55 Cargo Hook.....	10
Table 4.2 Component Weights	10
Table 5.1 Cargo Hook Electrical Connector.....	26
Table 8.1 AH Common Beam External Cargo Hook System - Single Hook.....	36
Table 8.2 AH Common Beam External Cargo Handling System - Dual Hook	37
Table 8.3 Single Master Cylinder Assembly P/N 232-626-10.....	38
Table 8.4 Dual Master Cylinder Assembly P/N 232-626-11	39
Table 8.5 Master Cylinder Sub Assembly – Port P/N 232-641-10.....	41
Table 8.6 Master Cylinder Subassembly – Starboard P/N 232-643-10.....	43
Table 8.7 Master Cylinder Plumbing Assembly – Hook 1 & 2 P/N 232-632-00.....	44
Table 8.8 Intermediate Plumbing Assembly - Hook 1 P/N 232-639-00 & Hook 2 P/N 232-638-00.....	45
Table 8.9 Cargo Hook/Slave Cylinder Assembly P/N 232-637-00	46
Table 8.10 Slave Cylinder With Plumbing P/N 232-634-00	47
Table 8.11 Slave Cylinder Assembly P/N 232-169-01.....	48

TABLE OF FIGURES

Figure 4.1 Master Cylinder Assemblies – EC145T2.....	8
Figure 4.2 Cargo Hook (232-637-00) - Manual Release Side	9
Figure 4.3 Cargo Hook (232-637-00)- Electrical Release Side	9
Figure 5.1 Cargo Hook Installation	13
Figure 5.2 Bleed Kit 212-038-00	15
Figure 5.3 Connecting Bleed Kit to Intermediate Lines	16
Figure 5.4 Master Cylinder Initial Filling Position	17
Figure 5.5 Filling Reservoir	17
Figure 5.6 Lever Pivot Dowel Pin Installation	18
Figure 5.7 Lockout Installation	19
Figure 5.8 Positioning the Single Hook Clamp to the Collective.....	20
Figure 5.9 Positioning the Dual Hook Starboard Assembly to the Collective	20
Figure 5.10 Installing the Port Master Cylinder Assembly – Single Hook	21
Figure 5.11 Installing the Port Master Cylinder Assembly – Dual Hook	21
Figure 5.12 Socket Head Screw Installation	22
Figure 5.13 Socket Head Clamp Screw Installation	22
Figure 5.14 Checking System for Air	23
Figure 5.15 Installing Safety Cable on Screws	24
Figure 5.16 Bleed Kit 212-014-02	24
Figure 5.17 Screw, Washers, and Thread Seal Removal.....	25
Figure 5.18 Injecting Hydraulic Fluid.....	25
Figure 5.19 Safety Wire Slave Cylinder	26
Figure 5.20 Hook Locked Indicator	27
Figure 6.1 Cargo Hook Loading	29
Figure 6.2 Example of Recommended Cargo Hook Rigging.....	31
Figure 7.1 Lever Adjustment.....	34
Figure 7.2 Ball Nose Spring Plunger Adjustment.....	35
Figure 8.1 AH Common Beam External Cargo Hook System – Single Hook EC145T2	36
Figure 8.2 AH Common Beam External Cargo Handling System - Dual Hook EC145T2.....	37
Figure 8.3 Single Master Cylinder Assembly P/N 232-626-10	38
Figure 8.4 Dual Master Cylinder Assembly P/N 232-626-11	39
Figure 8.5 Master Cylinder Sub Assembly – Port P/N 232-641-10	40

	Owner's Manual Airbus Helicopters Common Beam EC145T2	Document Number 120-217-00	Revision 8
		Date 07/15/21	Page 5 of 48

Figure 8.6 Master Cylinder Subassembly – Starboard P/N 232-643-10 42

Figure 8.7 Master Cylinder Plumbing Assembly – Hook 1 & 2 P/N 232-632-00 44

Figure 8.8 Intermediate Plumbing Assembly - Hook 1 P/N 232-639-00 & Hook 2 P/N 232-638-00 45

Figure 8.9 Cargo Hook/Slave Cylinder Assembly P/N 232-637-00 46

Figure 8.10 Slave Cylinder With Plumbing P/N 232-634-00 47

Figure 8.11 Slave Cylinder Assembly P/N 232-169-01 48

	Owner's Manual Airbus Helicopters Common Beam EC145T2	Document Number 120-217-00	Revision 8
		Date 07/15/21	Page 6 of 48

1.0 Introduction

1.1 Scope

This document provides instructions for installation, operation, and maintenance of the Airbus Helicopter EC145T2 Single & Dual Hook Common Beam External Cargo Handling Systems. The systems include fixed and removable provisions.

The fixed provisions are Dual Master Cylinder with Plumbing Assembly, P/N 232-626-11, or Single Master Cylinder with Plumbing Assembly, P/N 232-626-10. The removable provisions are Cargo Hook Slave Cylinder Assembly, P/N 232-637-00 and Intermediate Plumbing Assembly, Hook 1, P/N 232-639-00 and Intermediate Plumbing Assembly, Hook 2, P/N 232-638-00.

1.2 Capability

The instructions contained in this document are provided for the benefit of experienced aircraft maintenance personnel and facilities that are capable of carrying out the procedures.

1.3 Safety Labels

The following definitions apply to safety labels used in this manual.



Indicates a hazardous situation which, if not avoided, will result in death or serious injury.



Indicates a hazardous situation which, if not avoided, could result in death or serious injury.



Indicates a hazardous situation which, if not avoided, could result in minor or moderate injury.



Draws the reader's attention to important or unusual information not directly related to safety.



Used to address practices not related to personal injury.

	Owner's Manual Airbus Helicopters Common Beam EC145T2	Document Number 120-217-00	Revision 8
		Date 07/15/21	Page 7 of 48

2.0 Referenced Documents

122-015-00	Component Maintenance Manual, Cargo Hook
145-123-00	Interface Control Drawing – EC145T2
180-169-00	Acceptance Test Procedure – Talon LC Hydraulic Hook
180-235-00	Acceptance Test Procedure – EC Common Beam Master Cylinder
159-048-00	Service Bulletin – Common Beam Master Cylinder Leakage

3.0 Special Tools

212-038-00	Bleed Kit – Staubli Fitting MIL-PRF-87257
212-014-02	Bleed Kit - Hydraulic Hook MIL-PRF-87257

4.0 System Overview

4.1 Description/Theory of Operation

The cargo hook systems are comprised of fixed and removable provisions.

The fixed provisions consists of the backup release system which features the hydraulic master cylinder assembly, and hydraulic hose mounted inside the aircraft down to the interface panel on the underside of the fuselage. The interface panel provides the means for mounting the connectors between the fixed and removable sections of the release system. The fixed provisions are typically left on the helicopter when it is configured for an operation other than external load operations. The electrical system that connects to the cargo hooks for normal release is supplied by Airbus Helicopters.

The backup release system uses a self-contained hydraulic system to provide a means of releasing a cargo hook load in the event of an electrical release system failure. A lever, one for each cargo hook included with the fixed provisions kit, is mounted on the pilot collective tube. To prevent unintended release, the master cylinders feature a Dual Action Device (DAD) in the form of a Lever Lockout mechanism. A tab extending under the port side of the levers must first be moved down; and then the lever(s) may be actuated. See Figure 4.1.

The removable provisions include the components external to the helicopter which are easily removed when the helicopter is configured for an operation other than external load operations. It includes:

- The cargo hook(s).
- The external portions of the manual release system.

	Owner's Manual Airbus Helicopters Common Beam EC145T2	Document Number 120-217-00	Revision 8
		Date 07/15/21	Page 8 of 48

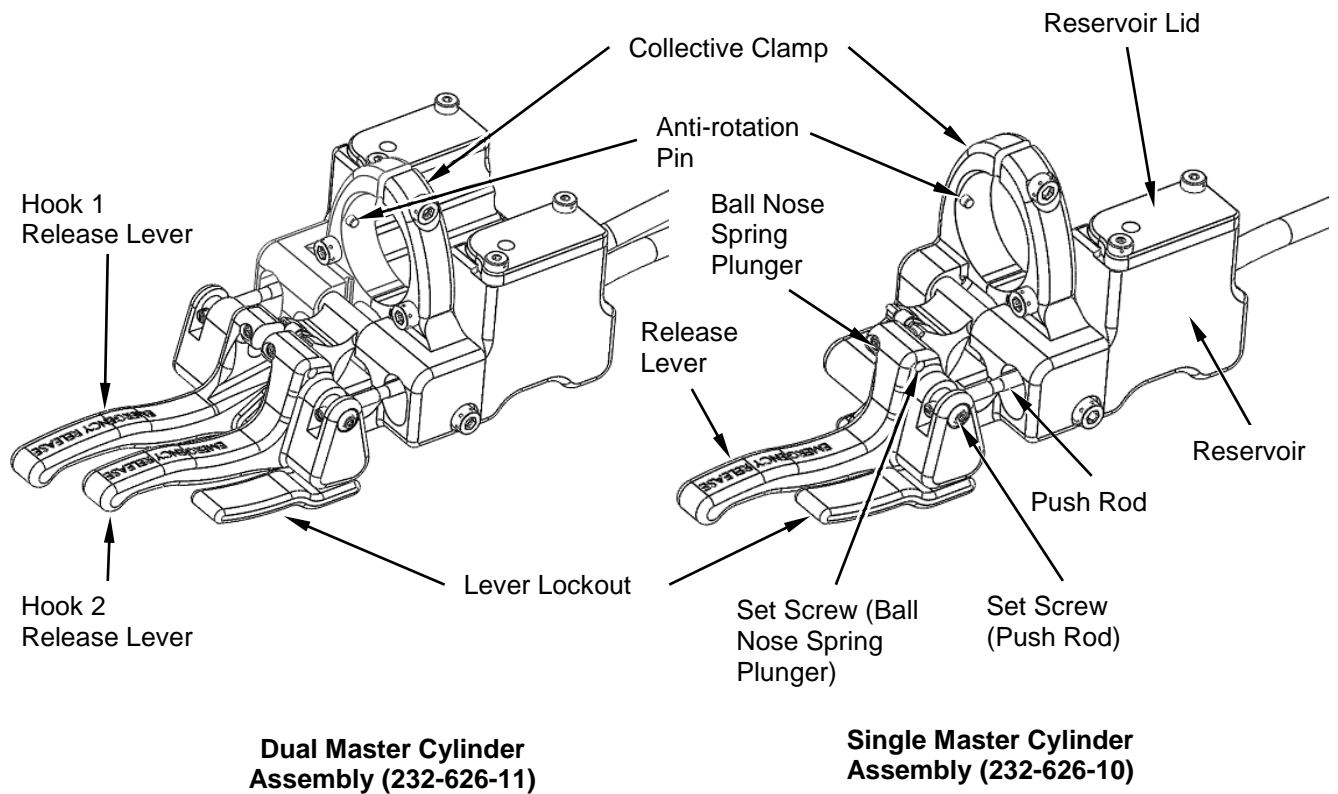



Figure 4.1 Master Cylinder Assemblies – EC145T2

A load is attached to the cargo hook by passing a cargo load ring into the throat of the load beam and pushing the ring against the upper portion of the load beam throat, which will cause the hook to close. In the closed position, a latch engages the load beam and latches it in this position.

To release the load, the latch is disengaged from the load beam. With the latch disengaged, the weight of the load causes the load beam to swing to its open position, and the cargo sling ring slides off the load beam. The load beam then remains in the open position awaiting the next load.

Ground personnel may also release an external load by actuating the manual release lever, located on the side of the cargo hook. See Figure 4.2.

	Owner's Manual Airbus Helicopters Common Beam EC145T2	Document Number 120-217-00	Revision 8
		Date 07/15/21	Page 9 of 48

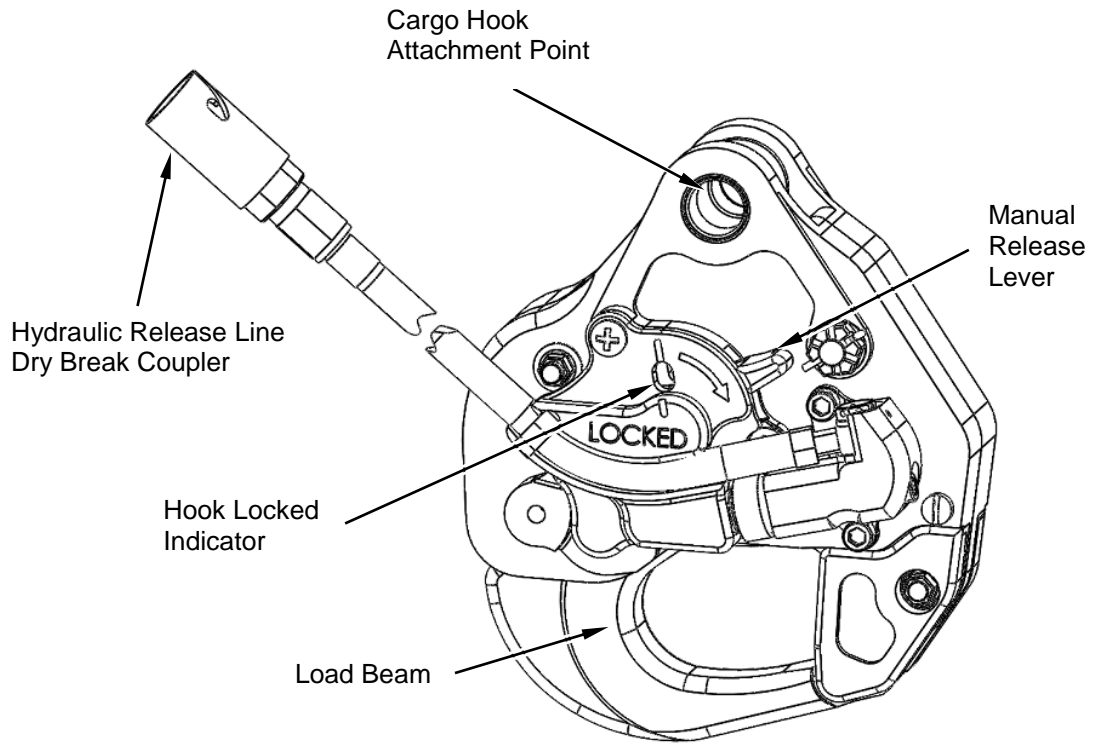

Figure 4.2 Cargo Hook (232-637-00) - Manual Release Side

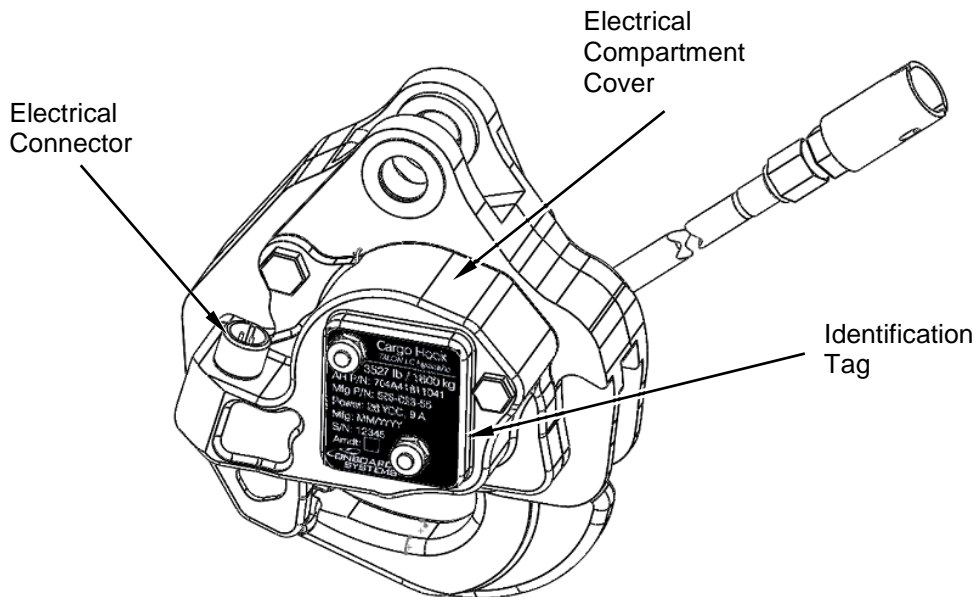



Figure 4.3 Cargo Hook (232-637-00)- Electrical Release Side

	Owner's Manual Airbus Helicopters Common Beam EC145T2	Document Number 120-217-00	Revision 8
		Date 07/15/21	Page 10 of 48

4.2 Specifications

Table 4.1 Specifications - P/N 528-028-55 Cargo Hook

Design load*	1600 kg (3,527 lb)
Design ultimate strength	6000 kg (13,226 lb)
Electrical release capacity	4000 kg (8,818 lb)
Mechanical release capacity	4000 kg (8,818 lb)
Force required for manual release at 3,527 lb.	145 N (32 lb) maximum @ Master Cylinder
Hydraulic release system – operating temperature rating	-49°F to 158°F (-45°C to 70°C)
Electrical requirements	22-32 VDC 6.9 – 10 amps
Minimum release load	0 kg
Unit weight	1.35 kg (3.0 lb)
Mating electrical connector	PC05A8-2S

Table 4.2 Component Weights

Part Number	Description	Approx. Weight kg (lb)
232-626-11	Dual Master Cylinder with Plumbing Assembly	1.0 (2.2)
232-626-10	Single Master Cylinder with Plumbing Assembly	0.6 (1.3)
232-637-00	Cargo Hook/Slave Cylinder Assembly	1.4 (3.1)
232-639-00	Intermediate Plumbing Assembly Hook 1	0.2 (0.4)
232-638-00	Intermediate Plumbing Assembly Hook 2	0.1 (0.3)



**Load capacities given are for the equipment described only. Loading limits for your particular helicopter model still apply. Consult your flight manual.*

	Owner's Manual Airbus Helicopters Common Beam EC145T2	Document Number 120-217-00	Revision 8
		Date 07/15/21	Page 11 of 48

4.3 Bill of Materials

Each system (single and dual hook) is comprised of fixed and removable provisions.

4.3.1 Single Cargo Hook System - EC145T2

Fixed Provisions:

P/N	DESCRIPTION	QTY
232-626-10	Single Master Cylinder Assembly	1

Removable Provisions:

Onboard Systems P/N 210-278-00 Removable Provisions - Single

P/N	Description	QTY
232-637-00	Cargo Hook/Slave Cylinder Assembly	1
232-639-00	Intermediate Plumbing Assembly Hook 1	1
560-012-00	Dust Cap	1
560-013-00	Dust Cap	1

4.3.2 Dual Cargo Hook System - EC145T2

Fixed Provisions:

P/N	Description	QTY
232-626-11	Dual Master Cylinder Assembly	1

Removable Provisions:

Onboard Systems P/N 210-278-10 Removable Provisions – Dual

P/N	Description	QTY
232-637-00	Cargo Hook/Slave Cylinder Assembly	2
232-638-00	Intermediate Plumbing Assembly Hook 2	1
232-639-00	Intermediate Plumbing Assembly Hook 1	1
560-012-00	Dust Cap	2
560-013-00	Dust Cap	2

	Owner's Manual Airbus Helicopters Common Beam EC145T2	Document Number 120-217-00	Revision 8
		Date 07/15/21	Page 12 of 48

5.0 Installation Instructions

5.1 Install Cargo Hooks and Hydraulic Lines

NOTICE

Use best shop practices to keep foreign material out of the hydraulic system. FOD will plug orifices, damage seals and/or scratch sealing surfaces necessitating system rebuild. Use only clean hydraulic fluid from sealed containers.

The following instructions are for the dual hook installation. The single hook configuration is the same except hook 2 and its associated components are disregarded.

When installing hydraulic lines make sure the bend radius is no less than 40mm (1.5").

1. At the end of the master cylinder hydraulic line(s) mount the dry break coupler on the interface plate (on the underside of the fuselage) with the included nut. Torque to 10-13 N·m (7-10 ft·lb). If lines need to be opened, re-torque to 8-11.5 N·m (6-8.5 ft·lb).
2. Secure the hydraulic lines to the airframe with cushioned loop clamps below the cockpit floor. Do not secure the lines to the collective tube at this time.
3. Install the intermediate plumbing assemblies (232-639-00 for hook 1, 232-638-00 for hook 2) on the support beam. Mount the dry break couplers to their respective brackets with the included nuts. Torque to 10-13 N·m (7-10 ft·lb). If lines need to be opened, re-torque to 8-11.5 N·m (6-8.5 ft·lb).
4. Mate the dry break couplers at the interface plate.
5. Finish routing and securing the intermediate plumbing assemblies to the support beam with cushioned loop clamps.

- Attach each Cargo Hook/Slave Cylinder Assembly (232-637-00) to the trunnions in the support beam. For each cargo hook, use one attach bolt (290-332-00), two washers (510-183-00) one on each side of the cargo hook, one washer (510-174-00) and castellated nut (510-780-00). Tighten nut until it is fully seated. If necessary, back the nut off until the hole in the bolt can be accessed in the next slot and install the cotter pin (510-178-00).

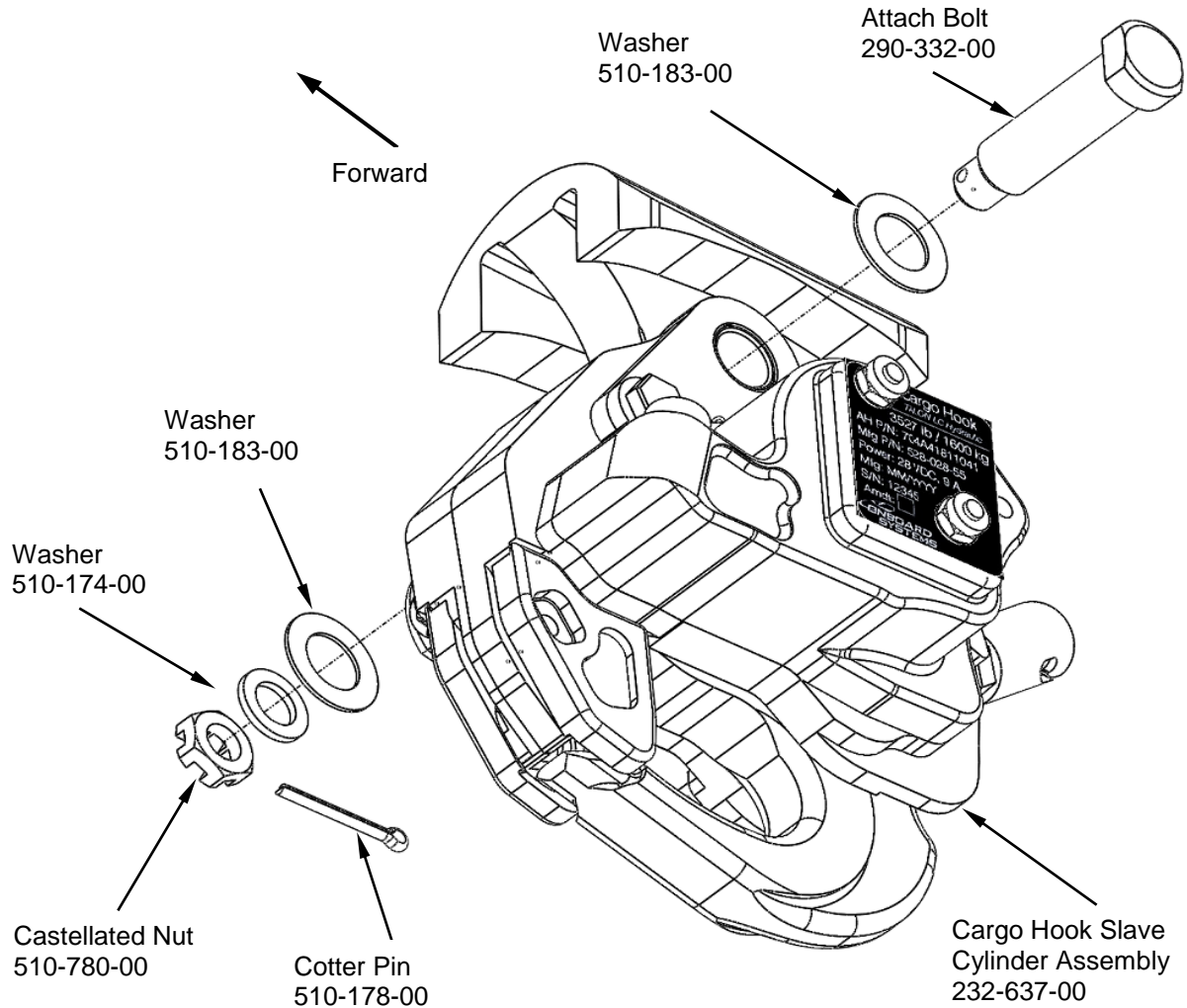



Figure 5.1 Cargo Hook Installation

	Owner's Manual Airbus Helicopters Common Beam EC145T2	Document Number 120-217-00	Revision 8
		Date 07/15/21	Page 14 of 48

5.2 Fill and Bleed Hydraulic System – Initial Installation

Separate the two master cylinder assemblies or the clamp from the single master cylinder by removing the two socket head mounting screws holding them together. For the dual hook installation bleed one system at a time.

Place an absorbent towel in the work area under the master cylinders.

The slave cylinder section from the cargo hook to the dry break coupler is supplied filled with hydraulic fluid and bled. The intermediate hydraulic line assemblies as well as the internal cockpit section, including the reservoir at the release lever assembly are supplied empty.

In the event that the slave cylinder requires servicing and needs to be bled, see section 5.5 for instructions.

The bleeding process back feeds hydraulic fluid through the system up to the master cylinder. The process will require two people, one to inject hydraulic fluid through the system and the other to observe the reservoir.

To ensure no air is trapped during the bleeding process the hydraulic lines must be routed with a gradual upward slope with no high or low spots.

NOTICE

The reservoir seal is for shipping purposes only and must be removed and discarded before bleeding of the hydraulic release system.

1. Prepare the master cylinders. Remove the two shoulder screws (291-853-00) retaining the reservoir lids (291-852-00), set the aluminum protective plate aside (this plate is for shipping purposes only), and then re-install the reservoir lids with the shoulder screws. Verify that baffle/fluid level indicator plates are in position. Torque shoulder screws (291-853-00) to 0.6 N·m (5 in·lb) maximum.

NOTICE

MIL-PRF-87257 and MIL-PRF-5606 fluids are both compatible with the hydraulic system. These fluids are interchangeable and miscible.

2. Using recommended bleed kit P/N 212-038-00 which includes MIL-PRF-87257 fluid (or optionally use 212-034-00 which includes MIL-PRF-5606 fluid), fill the syringe with hydraulic fluid.



	Owner's Manual Airbus Helicopters Common Beam EC145T2	Document Number 120-217-00	Revision 8
		Date 07/15/21	Page 15 of 48

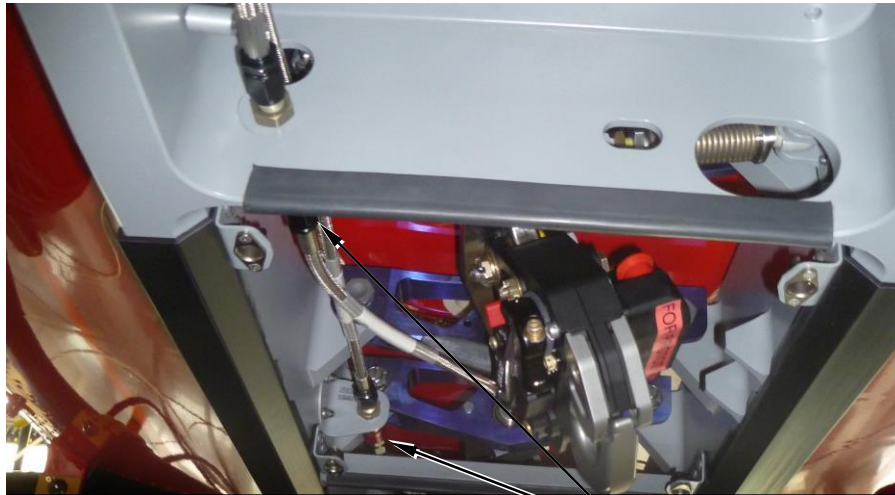

Figure 5.2 Bleed Kit 212-038-00

3. If only the Fixed Provision Master Cylinder is installed (without cargo hooks), the bleed kit may be connected directly to the dry break coupler on the interface panel.

	Owner's Manual Airbus Helicopters Common Beam EC145T2	Document Number 120-217-00	Revision 8
		Date 07/15/21	Page 16 of 48

- To bleed a complete system (fixed and removable provisions), or if the intermediate plumbing lines are installed, connect the female end of the dry break coupler of the bleed kit to the aft dry break coupler of the intermediate hydraulic line.



Aft

Connect Bleed Kit dry break coupler to Intermediate Line dry break couplers



Figure 5.3 Connecting Bleed Kit to Intermediate Lines

	Owner's Manual Airbus Helicopters Common Beam EC145T2	Document Number 120-217-00	Revision 8
		Date 07/15/21	Page 17 of 48

5. Hold the master cylinder on its side so the head of the banjo bolt (internally relieved bolt) is on the down side as shown in Figure 5.4. Slowly push on the syringe plunger to force fluid up to the master cylinder reservoir. Take care to orient the syringe downward so no air is injected. There will be some resistance during filling—this is normal. As soon as fluid begins to enter the reservoir turn the master cylinder upright. During the filling operation tap the master cylinder to loosen air bubbles that may be stuck inside the passage ways. Take care not to allow the vent hole to get below the level of the fluid so it doesn't spill. Slowly operate the lever a few times to help the forward portion of the piston chamber to fill. The dowel pin (single hook 511-085-00 or dual hook 511-086-00) must be temporarily inserted for this.

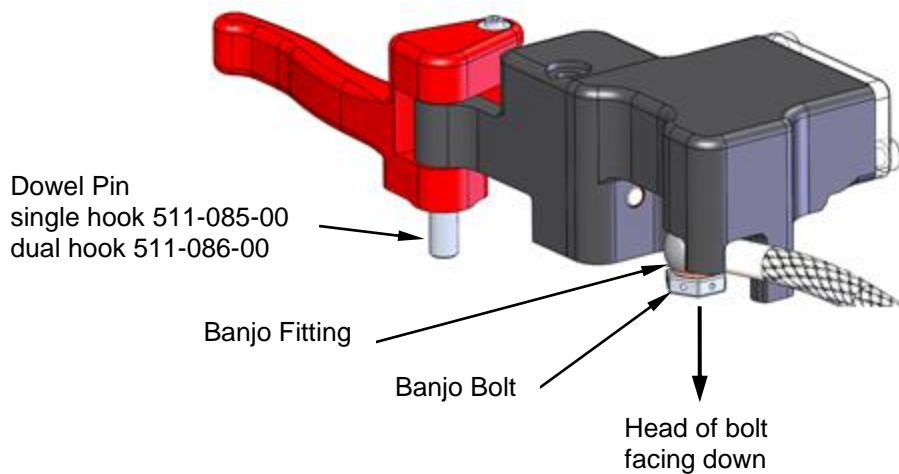

Figure 5.4 Master Cylinder Initial Filling Position

6. Continue filling the reservoir until fluid level is at the min line when the assembly is held at an approximate 20° angle (park position of collective lever). The final fluid level will be adjusted later.

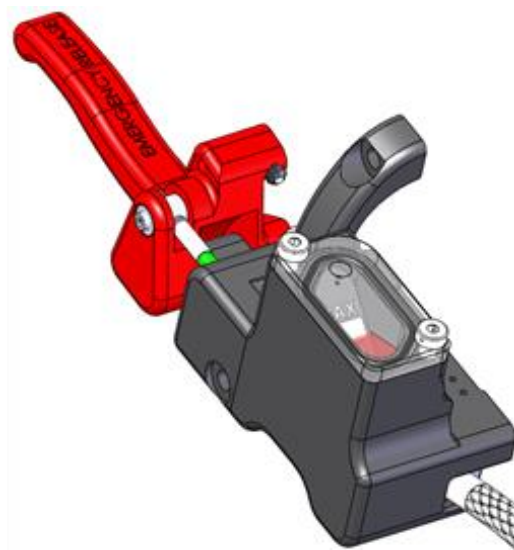



Figure 5.5 Filling Reservoir

	Owner's Manual Airbus Helicopters Common Beam EC145T2	Document Number 120-217-00	Revision 8
		Date 07/15/21	Page 18 of 48

5.3 Install Master Cylinder Assemblies

1. Line up the holes in the Lever and the pivot hole in the Clamp and insert the lever pivot dowel pin (P/N 511-085-00 for single hook configuration or P/N 511-086-00 for dual hook).

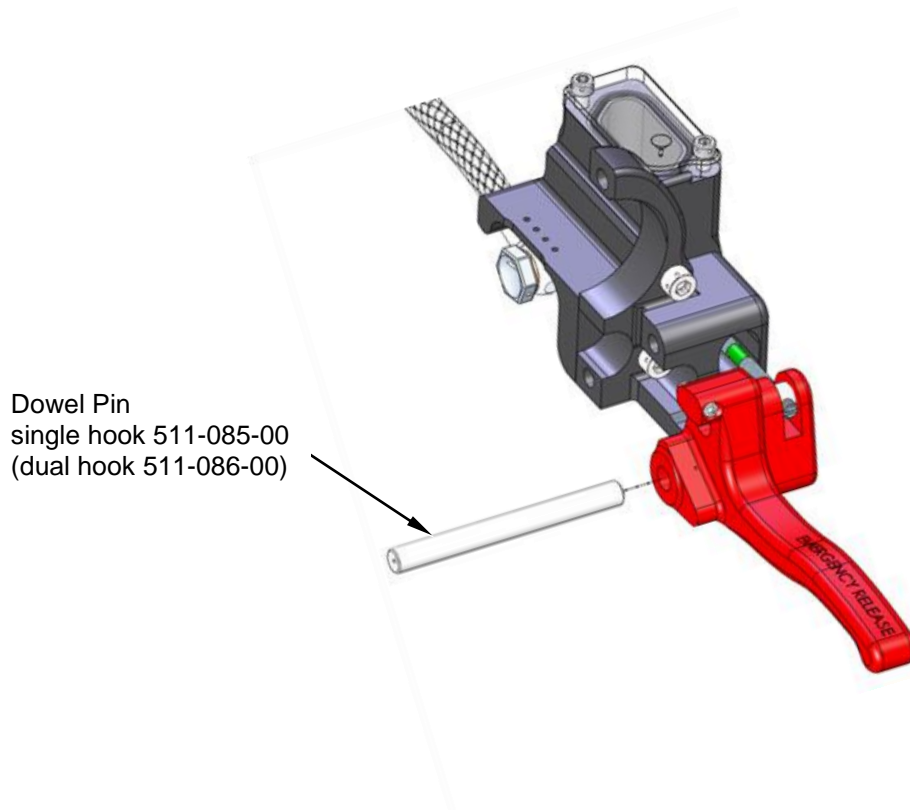



Figure 5.6 Lever Pivot Dowel Pin Installation

	Owner's Manual Airbus Helicopters Common Beam EC145T2	Document Number 120-217-00	Revision 8
		Date 07/15/21	Page 19 of 48

2. Insert the Lockout Lever Assembly (232-640-00) into the pivot hole in the Dual Cylinder Clamp (291-831-00).

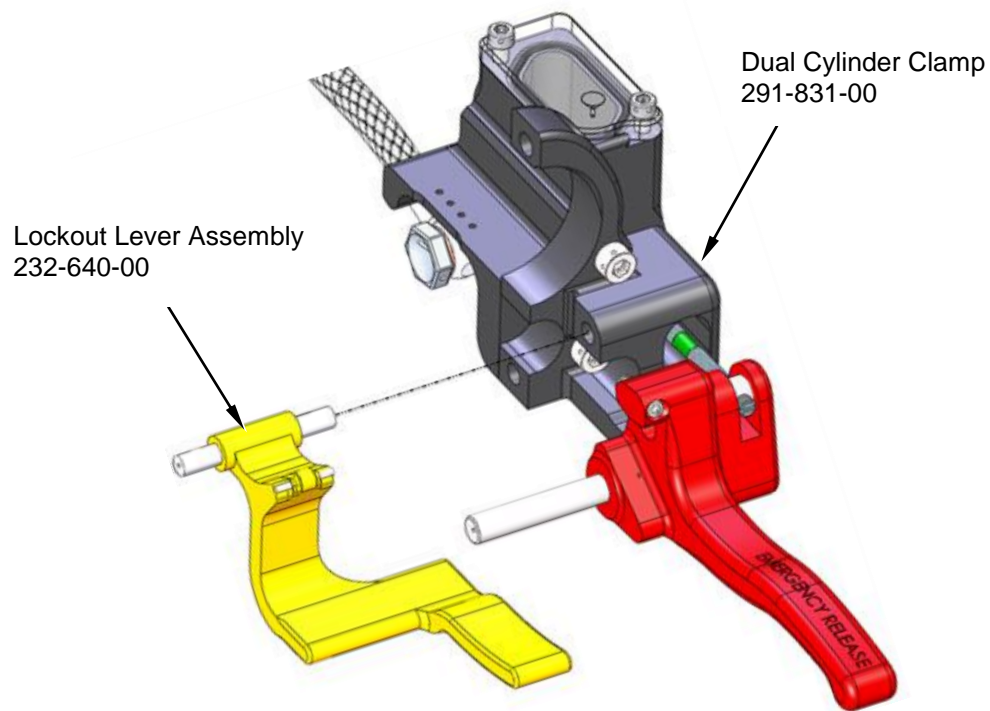

Figure 5.7 Lockout Installation

3. Position either the Master Cylinder Clamp (232-642-10) for the single hook system or the position the starboard half of the Master Cylinder Subassembly (232-641-10) for the dual hook system on the collective tube while lining up the anti-rotation pin in the hole.

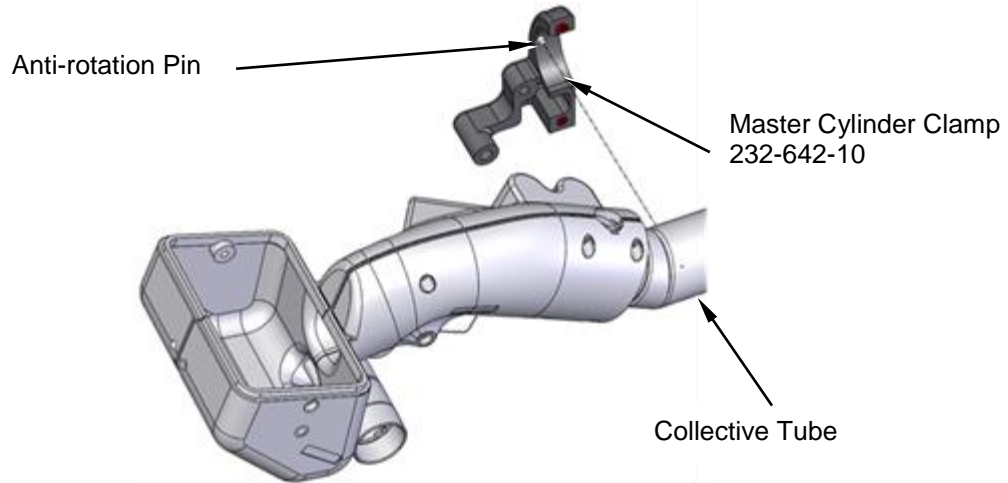

Figure 5.8 Positioning the Single Hook Clamp to the Collective

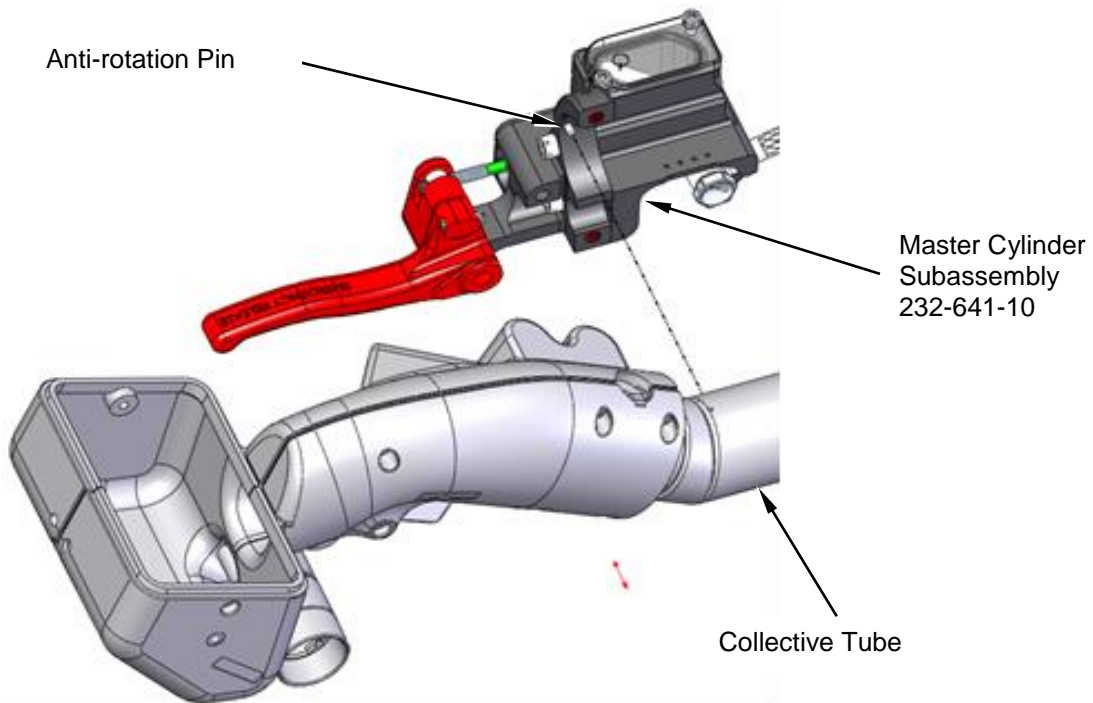

Figure 5.9 Positioning the Dual Hook Starboard Assembly to the Collective

- Position the port half of the Master Cylinder Subassembly (232-641-10) on the collective tube while aligning the lever pivot and lockout pivot shafts.

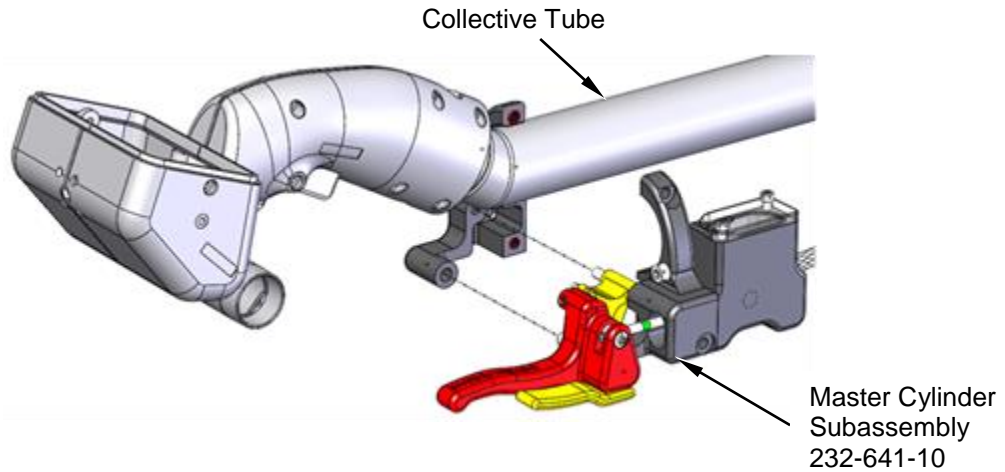

Figure 5.10 Installing the Port Master Cylinder Assembly – Single Hook

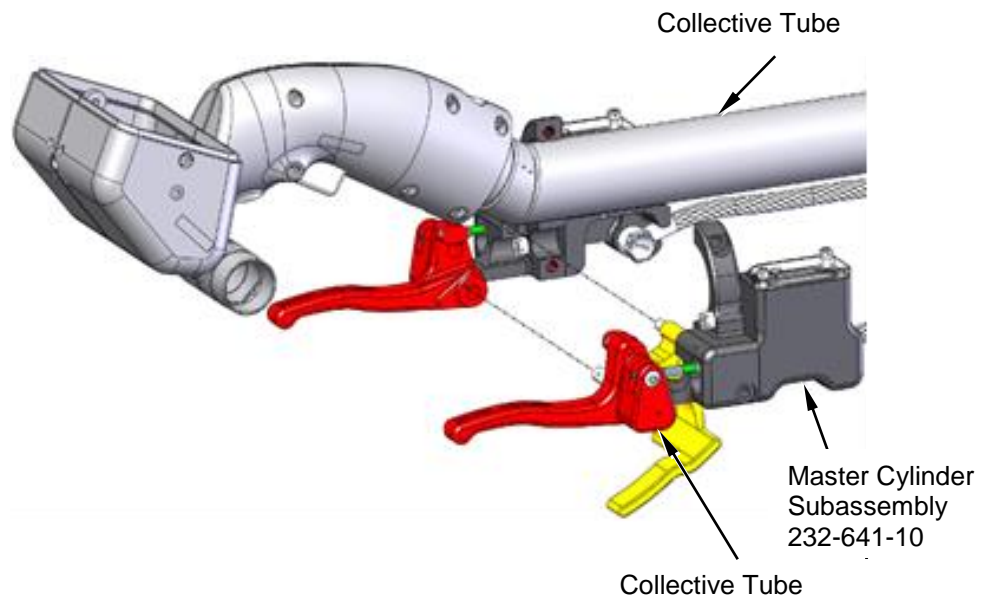



Figure 5.11 Installing the Port Master Cylinder Assembly – Dual Hook

	Owner's Manual Airbus Helicopters Common Beam EC145T2	Document Number 120-217-00	Revision 8
		Date 07/15/21	Page 22 of 48

- Install the lower socket head screw (511-081-00) to hold the two halves together. Torque to 2.3-2.8 N·m (20-25 in·lb)

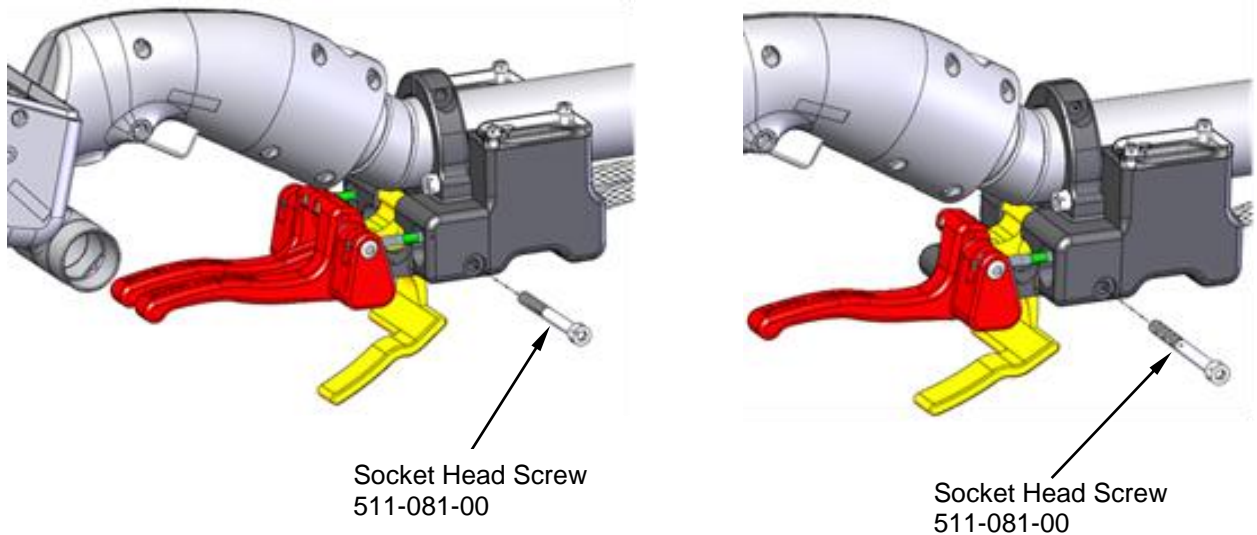

Figure 5.12 Socket Head Screw Installation

- Install the upper socket head screw (511-080-00) and tighten until assembly is secure. Do not exceed 4.0 N·m (35 in·lb).

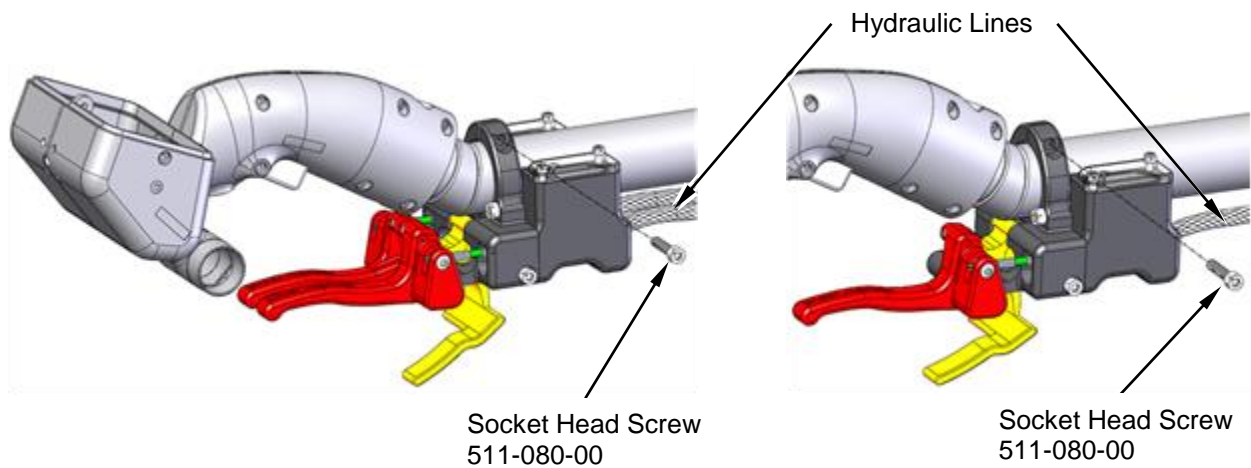



Figure 5.13 Socket Head Clamp Screw Installation

- Secure the hydraulic lines to the collective tube per Airbus instructions.

	Owner's Manual Airbus Helicopters Common Beam EC145T2	Document Number 120-217-00	Revision 8
		Date 07/15/21	Page 23 of 48

5.4 Hydraulic System Operation Check

1. Very **slowly** cycle each of the release levers in order to move the piston a small amount (approximately 1.5mm) back and forth and watch for bubbles. If bubbles are observed rising within the reservoir, continue to slowly cycle the levers until there are no more. Actuating the levers releases air trapped within the system.
2. Check the system for air by actuating the lever firmly until it bottoms out. (Note, the cargo hook must be connected during this test). Check the push rod position as shown in Figure 5.14. If the green area on the push rod is visible above the reference surface, proceed to step 7.
3. If the green on the push rod is not visible with the lever completely pulled, the system has too much air in it and needs further bleeding. To do this, set the collective in its lowest position, remove the reservoir lid, remove some fluid, and replace the lid, then repeat bleeding procedure in section 5.2. Fluid may need to be pumped through the system faster in order to ensure trapped air is forced through. Take care not to over fill the reservoir and cause fluid to leak out of the vent hole.

To help isolate where the air is, the dry break coupling at the interface plate may be disconnected and the levers re-checked for firmness. If the lever feels stiffer then the air is probably not in the master cylinder line. Reconnect that coupling and disconnect the slave cylinder coupling and test the feel of the lever again to see if the air is in the intermediate line.

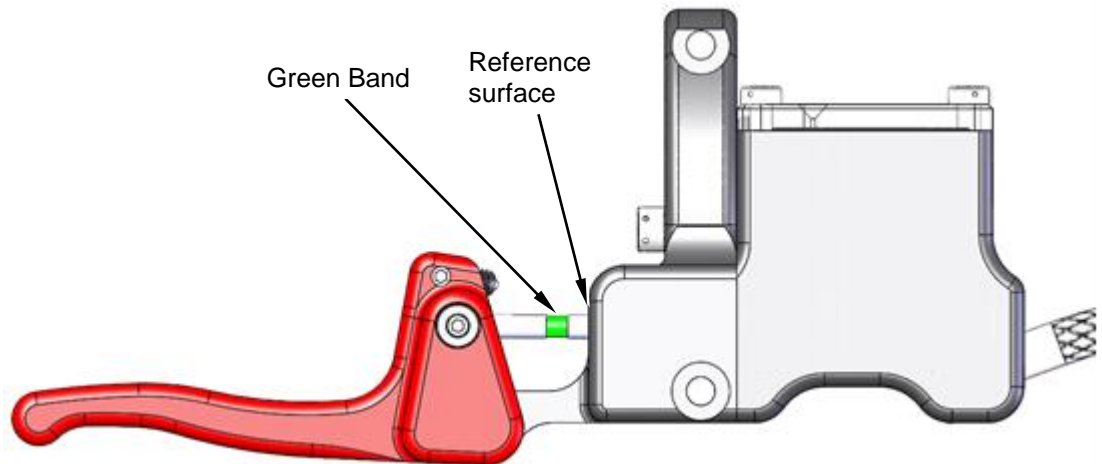



Figure 5.14 Checking System for Air

4. After the system is properly bled, verify that the fluid level is still in range with the collective control in the 20° park position. Adjust as necessary.
5. Check the release system for proper operation. Fully actuate the release lever. The hook must open and the lever must have a solid feel.
6. Disassemble and thoroughly clean the syringes with isopropyl alcohol. Allow to dry. *Not cleaning the syringes will render them unusable. Reassemble and store for next use.*

	Owner's Manual Airbus Helicopters Common Beam EC145T2	Document Number 120-217-00	Revision 8
		Date 07/15/21	Page 24 of 48

Install safety wire or cable to the mounting and reservoir lid screws as shown in Figure 5.15.

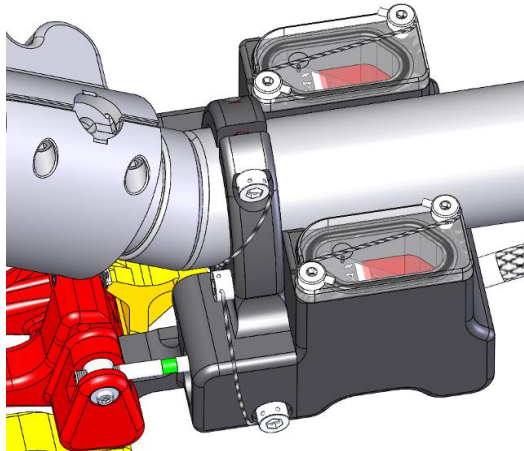

Figure 5.15 Installing Safety Cable on Screws

5.5 Slave Cylinder Bleeding Instructions

If it is suspected that the slave cylinder has air in it, or it has been serviced, use Bleed Kit 212-014-02 which includes MIL-PRF-87257 fluid (or optionally use 212-014-01 which includes MIL-PRF-5606 fluid) for the bleeding operation. Assemble the bleed kit as shown.

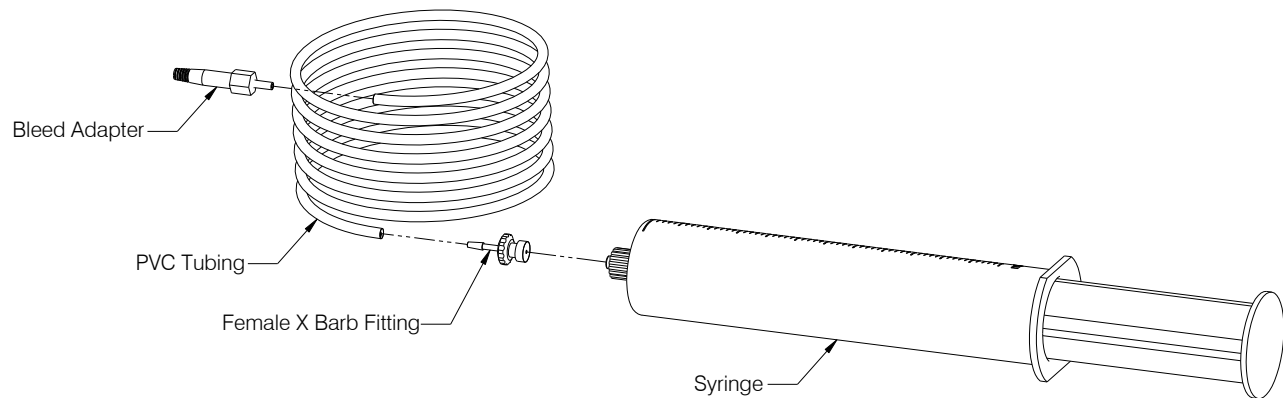



Figure 5.16 Bleed Kit 212-014-02

The following steps give instructions for bleeding just the slave cylinder and its plumbing in order to avoid introducing air into the rest of the system. If desired, the entire system may be bled up to the master cylinder through the slave cylinder with this kit.

1. Disconnect the dry break couplers between the slave cylinder line and the intermediate line.

	Owner's Manual Airbus Helicopters Common Beam EC145T2	Document Number 120-217-00	Revision 8
		Date 07/15/21	Page 25 of 48

- Remove the screw, washers and thread seal on the slave cylinder. See Figure 5.17.

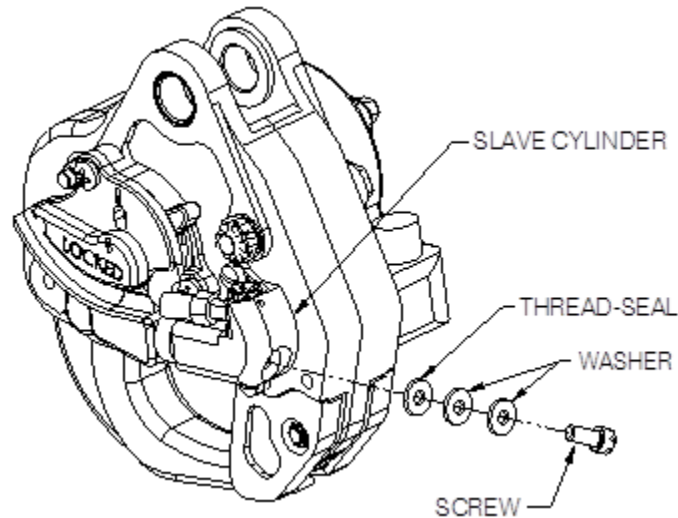

Figure 5.17 Screw, Washers, and Thread Seal Removal

- Fill the syringe with the provided hydraulic fluid and purge any remaining air in the syringe and tubing. Screw the end of the bleed adapter into the screw hole on the slave cylinder to create a tight seal. See Figure 5.18

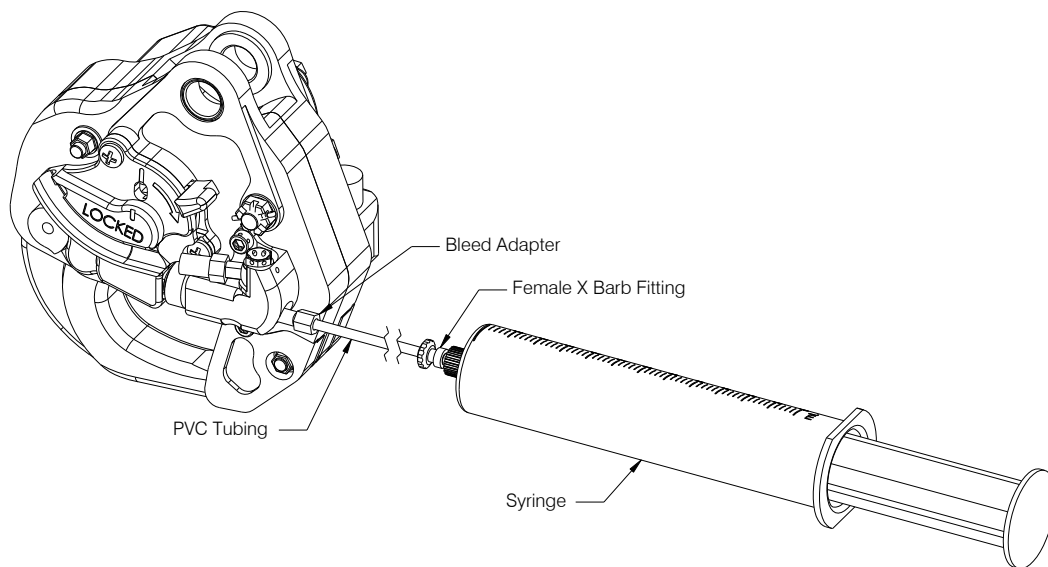



Figure 5.18 Injecting Hydraulic Fluid

- Connect a female dry break coupler to the slave cylinder line. Attach a clear tube to the female dry break coupler and run the tube into a container to collect the fluid.
- Slowly push on the syringe plunger to force fluid through the slave cylinder, hydraulic hose, clear tube, and into the container. Continue forcing fluid through until no more air can be seen in the clear tube.

	Owner's Manual Airbus Helicopters Common Beam EC145T2	Document Number 120-217-00	Revision 8
		Date 07/15/21	Page 26 of 48

6. Remove the bleed adapter from the screw hole. Re-install the thread seal, washers, and screw.
7. Disconnect the female dry break coupler and reconnect the slave cylinder coupler to the intermediate line.
8. Check the operation of the system per 5.4.
9. Add safety wire to the mounting and bleed screws. See Figure 5.19.

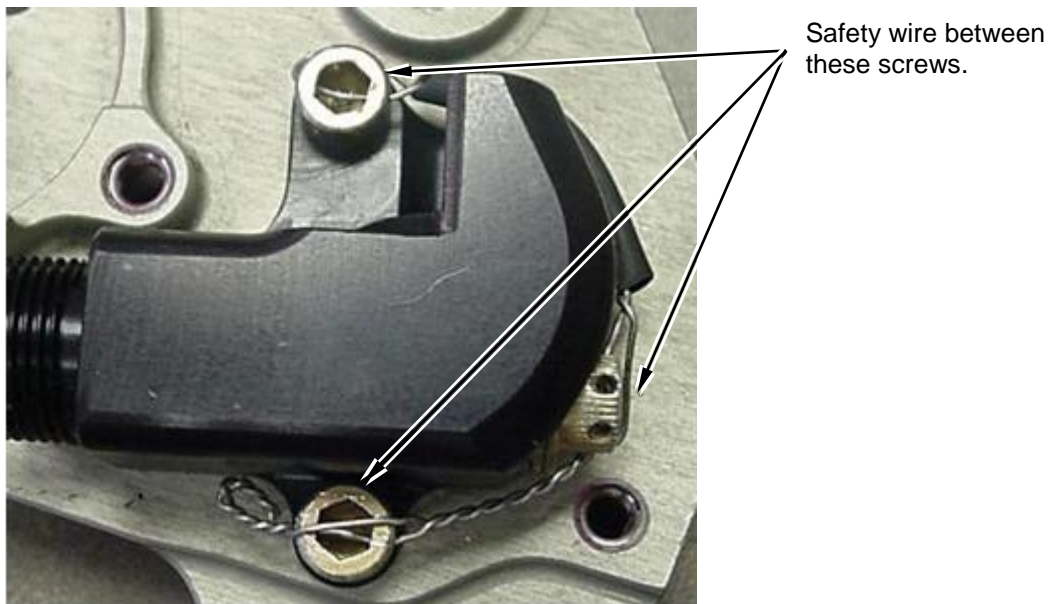



Figure 5.19 Safety Wire Slave Cylinder

5.6 Electrical Release

Mate the electrical harnesses on the support beam to their respective cargo hooks connectors. See Table 5.1 for electrical connector pin out information. Refer to Airbus instructions for more information on the cargo hook electrical system.

Table 5.1 Cargo Hook Electrical Connector

Pin	Function
A	Ground
B	Power

	Owner's Manual Airbus Helicopters Common Beam EC145T2	Document Number 120-217-00	Revision 8
		Date 07/15/21	Page 27 of 48

5.7 Installation Check-out

1. With no load on the cargo hook, activate the electrical release system by actuating the electrical release switch in the cockpit. The cargo hook must release. Return the load beam to its closed and locked position by hand after release.

CAUTION

The cargo hook release solenoid is intended to be energized only intermittently. Actuating the electrical release switch continuously in excess of 20 seconds will cause the solenoid to overheat, possibly causing permanent damage.

1. Check the release lever lockout mechanism. There should be a distinct snap-over as the lockout is moved from the locked to open position. If this is lacking, adjust the Ball Nose Spring Plungers per section 7.6. With no load on the cargo hook, activate the hydraulic release system by pulling the release lever on the collective in the cockpit. The mechanism should operate smoothly and the cargo hook must release. Return the release lever lockout mechanism to its locked position.
2. Return the load beam to its closed and locked position by hand after release. Verify that the hook lock indicator on the side of the hook returns to the fully locked position. In the fully locked position the hook lock indicator should align with the lines on the manual release cover (see Figure 5.20). If the hook does not release or re-latch, do not use the unit until the problem is resolved.

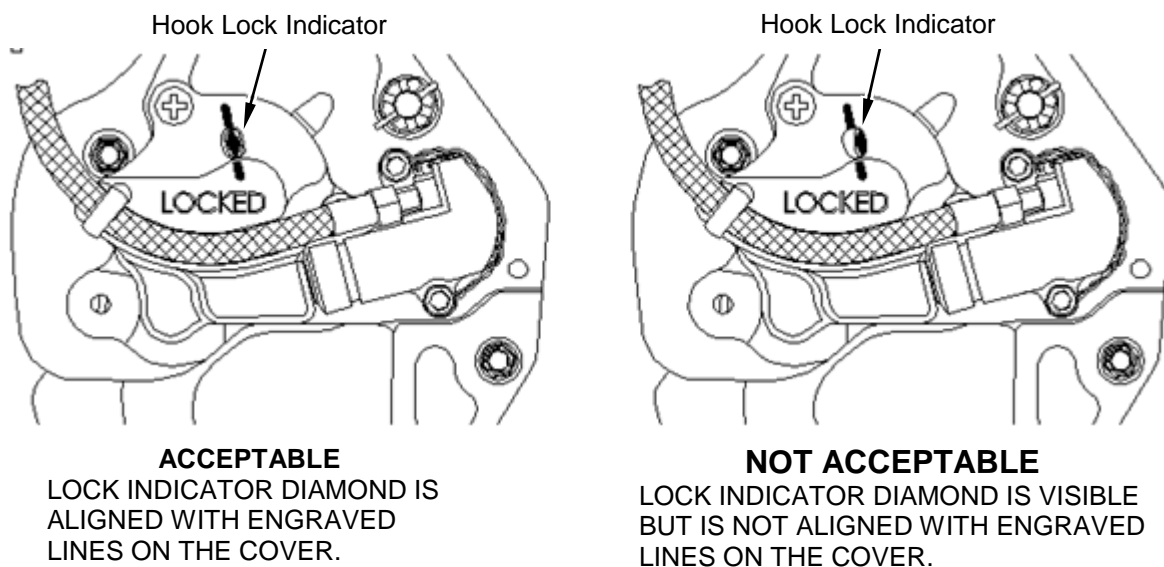



Figure 5.20 Hook Locked Indicator

	Owner's Manual Airbus Helicopters Common Beam EC145T2	Document Number 120-217-00	Revision 8
		Date 07/15/21	Page 28 of 48

6.0 Operation Instructions

6.1 Pre-Flight Check

Prior to a flight involving external load operations, perform the following:

1. Visually check for damage and/or corrosion on the exterior of the cargo hooks.
2. Move the cargo hooks throughout their range of motion; and observe the hydraulic hoses and electrical release harnesses to ensure that they have enough slack. The hydraulic hoses and electrical release harnesses must not be the stops that prevent the cargo hooks from moving freely in all directions.
3. Rotate the cargo hooks and gimbal assemblies about their pivot points to verify that they rotate freely.
4. Visually check the hydraulic hoses and their connections for damage and insecurity.
5. Visually check the electrical release harnesses and their connections for damage and insecurity.
6. Activate the electrical system and press the cargo electrical release buttons to ensure the cargo hook's electrical release systems are operating correctly. The cargo hooks must release. Reset the hooks by hand after release. If a hook does not release or re-latch, do not use the unit until the problem is fixed.

CAUTION

The cargo hook release solenoid is intended to be energized only intermittently. Actuating the electrical release switch continuously in excess of 20 seconds will cause the solenoid to overheat, possibly causing permanent damage.

7. Check the release lever lockout mechanism. There should be a distinct snap-over as the lockout is moved from the locked to unlocked position. If this is lacking adjust the Ball Nose Spring Plungers per section 7.6.
8. Activate the hydraulic release systems by pulling the release levers in the cockpit. The mechanisms should operate smoothly and the cargo hooks must release. Return the load beams to their closed and locked position by hand after release. Verify that the hook lock indicators on the side of the hooks return to the fully locked position. In the fully locked position the hook lock indicators should align with the lines on the manual release cover (see Figure 5.20). If a hook does not release or re-latch, do not use the unit until the problem is resolved. Return the release lever lockout mechanism to its place.
9. Check the fluid level in the master cylinder reservoirs. The master cylinder reservoirs feature transparent lids through which the fluid level can be checked. The hydraulic fluid must be between the max/min range marks on the baffle surface (see Figure 5.5).
10. Check the hydraulic release system for excess air in the lines by pulling the release levers firmly until they bottom out. Check the push rod positions (see Figure 5.14). If some of the green ring on the push rod is visible, the system is ready for use. If none of the green ring is visible, the system needs to be bled.

11. Check the entire hydraulic release system for leaks in the master cylinder bore, all fittings of the plumbing assemblies, and the slave cylinder assembly.

6.2 Cargo Hook Loading

The cargo hook can easily be loaded with one hand. A load is attached to the hook by pushing the ring upward against the upper portion of the load beam throat, as illustrated in Figure 6.1, until an internal latch engages the load beam and latches it in the closed position.

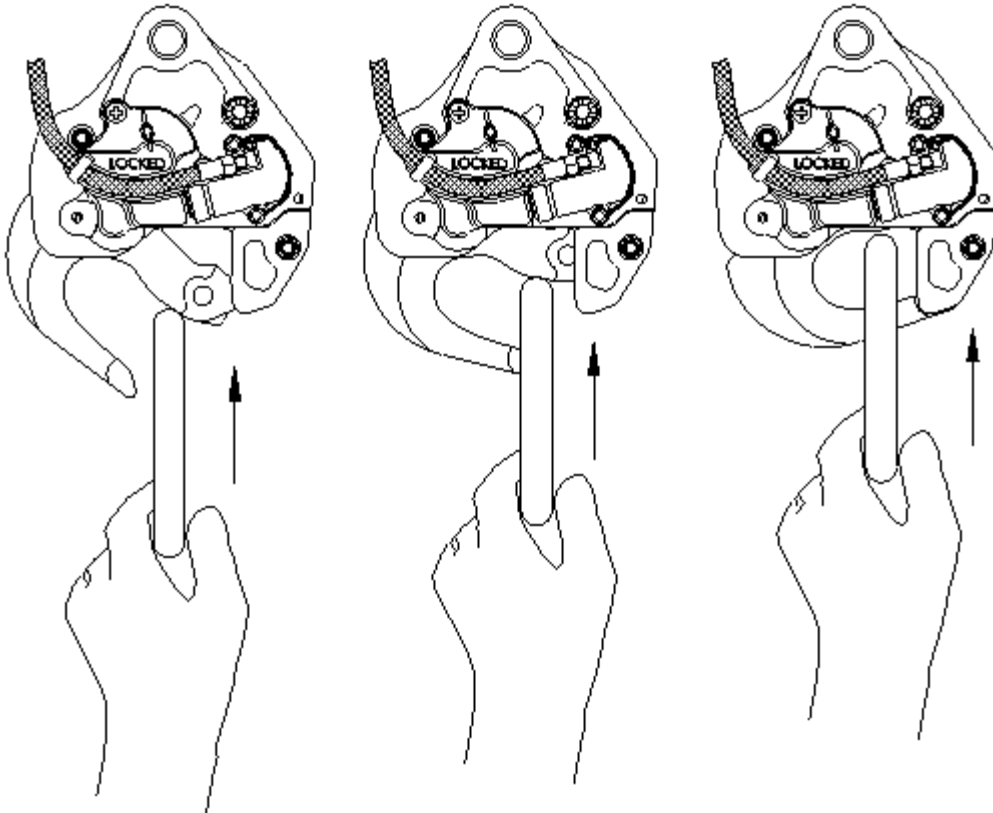



Figure 6.1 Cargo Hook Loading

	Owner's Manual Airbus Helicopters Common Beam EC145T2	Document Number 120-217-00	Revision 8
		Date 07/15/21	Page 30 of 48

6.3 Cargo Hook Rigging

Extreme care must be exercised when rigging a load to the cargo hook. Steel load rings are recommended to provide consistent release performance and resistance to fouling. The following illustration shows the recommended rigging, but is not intended to represent all rigging possibilities.

CAUTION

Some combinations of small primary rings and large secondary rings could cause fouling during release.

It is the responsibility of the operator to assure the cargo hook will function properly with each rigging.

CAUTION

Multiple load rings, nylon type straps (or similar material) or rope must not be used directly on the cargo hook load beam. If nylon straps or rope must be used they should be first attached to a steel primary ring. Verify that the ring will freely slide off the load beam when it is opened. Only the primary ring should be in contact with the cargo hook load beam.

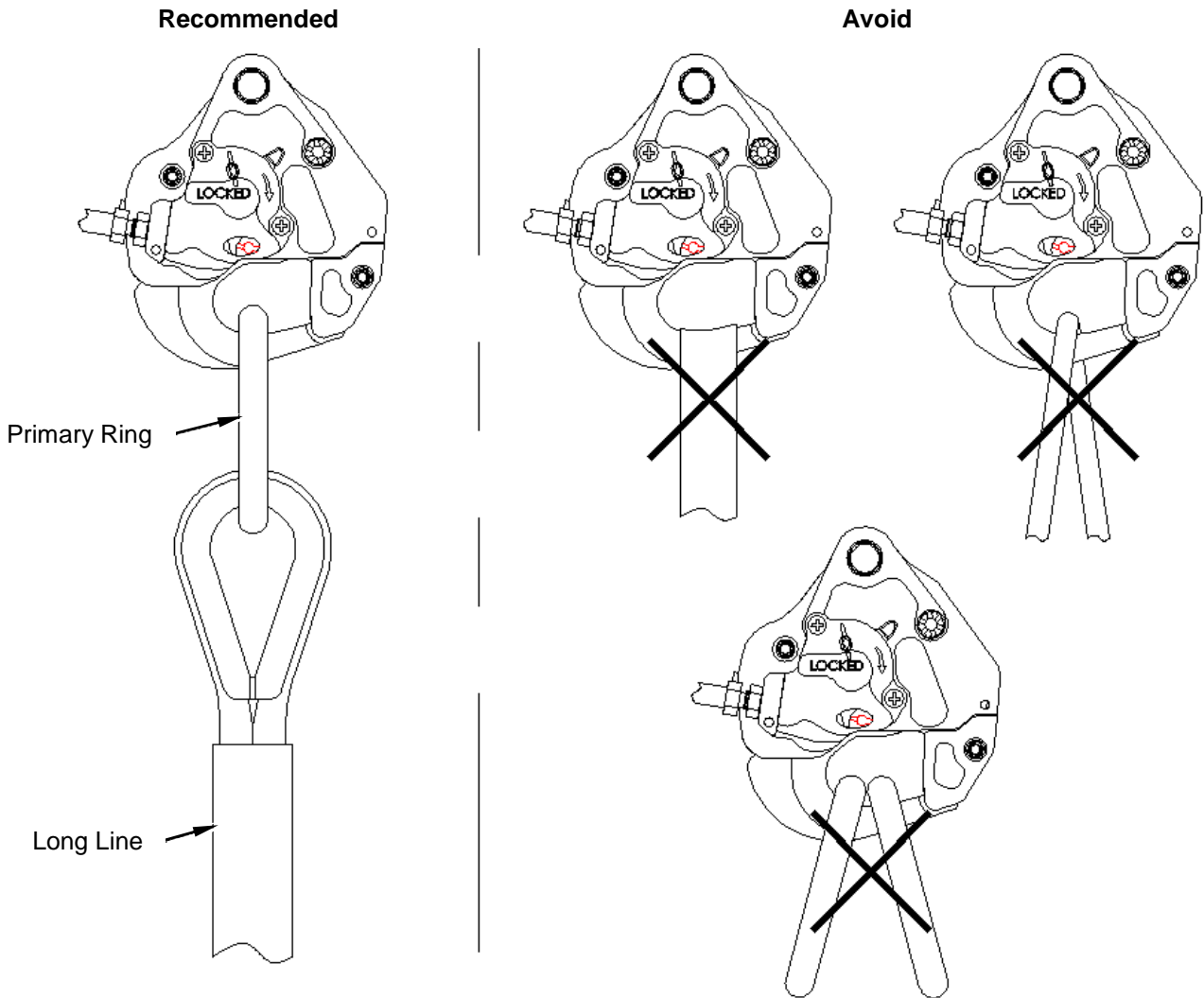



Figure 6.2 Example of Recommended Cargo Hook Rigging

	Owner's Manual Airbus Helicopters Common Beam EC145T2	Document Number 120-217-00	Revision 8
		Date 07/15/21	Page 32 of 48

7.0 Maintenance and Inspection

Verify proper operation of the entire system by performing the check in section 6.1

7.1 Cargo Hook

For maintenance specific to the cargo hook refer to the Cargo Hook Component Maintenance Manual 122-015-00. Note: the Cargo Hook Attach Bolt has the same maintenance requirements as the Cargo Hook.

7.2 Master Cylinder

7.2.1 Maintenance

The Master Cylinder Assembly requires no periodic maintenance.

7.2.2 100 hour/Annual Inspection

- Inspect for signs of fluid leakage in the area around the bore of the piston.
- Inspect for leakage around the fittings of the plumbing assemblies.
- Check the fluid level in the reservoir.
- Inspect for looseness of the mounting fasteners that clamp the master cylinder assembly to the collective handle.
- Inspect the lockout device for looseness. There should be a distinct snap-over as the lockout is moved from the locked to unlocked position.

7.3 Intermediate Plumbing Assemblies

7.3.1 Maintenance

The Intermediate Plumbing Assemblies require no periodic maintenance.

7.3.2 100 hour/ Annual Inspection

- Inspect for leakage in the hose around the fittings.

7.4 Slave Cylinder Assembly

7.4.1 Maintenance

The Slave Cylinder Assembly requires no periodic maintenance.

7.4.2 100 hour/Annual Inspection

- Inspect for signs of fluid leakage in the area around the bore of the piston.
- Inspect for leakage around the fittings of the plumbing assemblies.
- Inspect for signs of fluid leakage at the bleed screw.
- Inspect for looseness of the mounting screws that fasten the slave cylinder assembly to the body of the cargo hook.

	Owner's Manual Airbus Helicopters Common Beam EC145T2	Document Number 120-217-00	Revision 8
		Date 07/15/21	Page 33 of 48

7.5 Instructions for Returning Equipment to the Factory

If an Onboard Systems product must be returned to the factory for any reason (including returns, service, repairs, overhaul, etc.) obtain an RMA number before shipping your return.



An RMA number is required for all equipment returns.

- To obtain an RMA, please use one of the listed methods.
 - Contact Technical Support by phone or e-mail (Techhelp@OnboardSystems.com).
 - Generate an RMA number at our website: <http://www.onboardsystems.com/rma.php>
- After you have obtained the RMA number, please be sure to:
 - Package the component carefully to ensure safe transit.
 - Write the RMA number on the outside of the box or on the mailing label.
 - Include the RMA number and reason for the return on your purchase or work order.
 - Include your name, address, phone and fax number and email (as applicable).
 - Return the components freight, cartage, insurance and customs prepaid to:

Onboard Systems International
13915 NW 3rd Court
Vancouver, Washington 98685
USA
Phone: 360-546-3072

7.6 Lockout Adjustment

1. Remove the set screws (510-530-00) from the barrel nuts (290-812-00). Using a pair of calipers and a small screw driver adjust the pushrod until the distance from the forward face of the clamp to the inside of the barrel nut measures $25.15 \pm .1\text{mm}$ ($.990 \pm .005$ ”).
2. Adjust both levers of a dual system equally.
3. Replace the set screws in the barrel nuts and tighten them until light resistance is felt against the push rod.

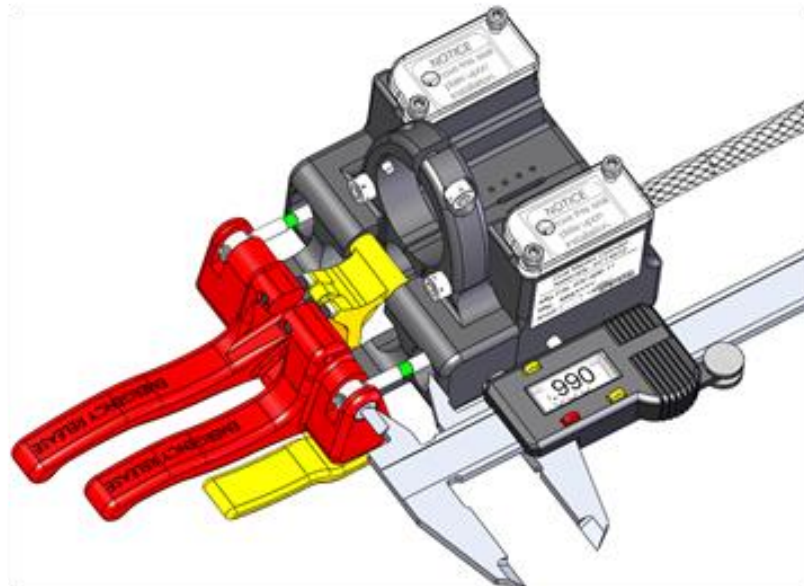
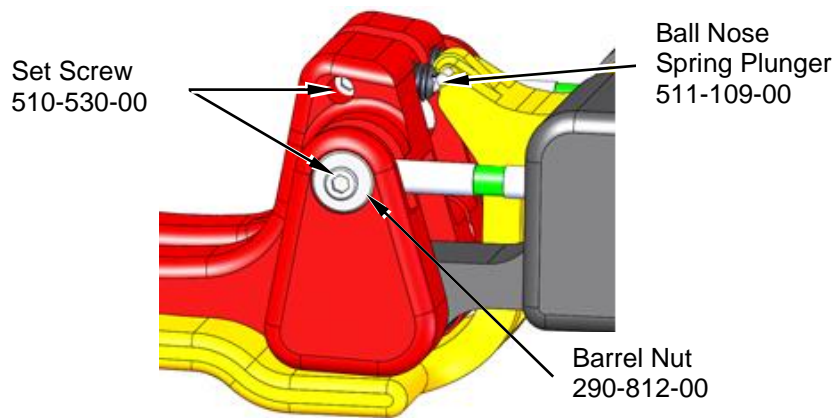



Figure 7.1 Lever Adjustment

	Owner's Manual Airbus Helicopters Common Beam EC145T2	Document Number 120-217-00	Revision 8
		Date 07/15/21	Page 35 of 48

4. Adjust the Ball Nose Spring Plungers (511-109-00). Loosen the set screws that act against the Ball Nose Spring Plungers. Move the Lockout Assembly into position and turn the Spring Plungers in until they are just starting to make contact with the Lockout Pin in the Lockout Assembly. Back off the Spring Plunger 1/8-1/4 turn. Check to see that there is .1-.2mm (.004-.008") clearance from the body to the pin.
5. Check the operation of the Lockout Assembly. The pin should not contact or scrape against the bodies of the Spring Plungers as the Lockout passes by. There must be a distinct snap-over when the pin passes over the Spring Plunger balls. If this is weak, turn in the Spring Plunger a small amount and check it again.
6. Re-tighten the set screws against the Spring Plungers until light resistance is felt.

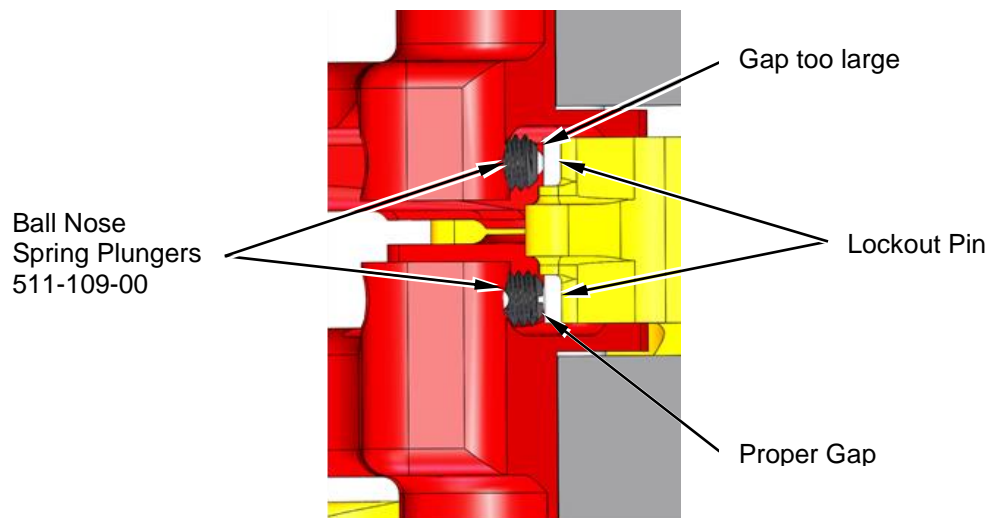



Figure 7.2 Ball Nose Spring Plunger Adjustment

	Owner's Manual Airbus Helicopters Common Beam EC145T2	Document Number 120-217-00	Revision 8
		Date 07/15/21	Page 36 of 48

8.0 Illustrated Parts List

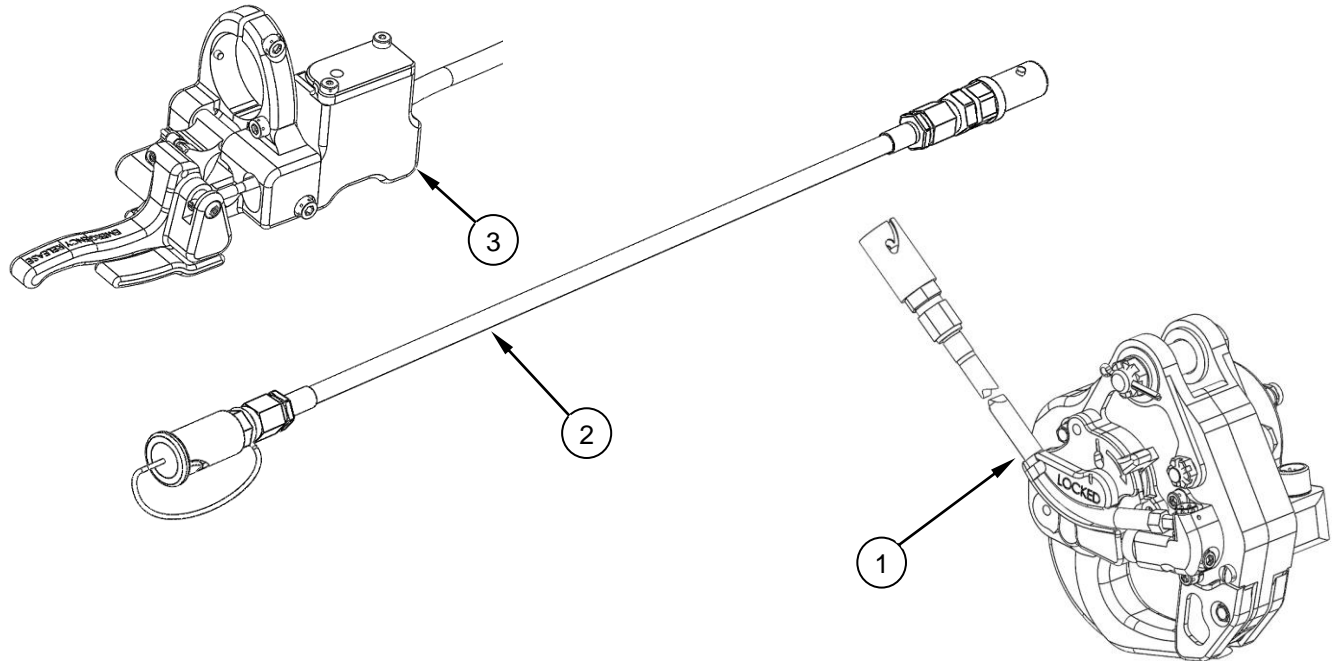

Figure 8.1 AH Common Beam External Cargo Hook System – Single Hook EC145T2

Table 8.1 AH Common Beam External Cargo Hook System - Single Hook

Item	P/N	Description	Qty
1	232-637-00	Cargo Hook Slave Cylinder Assembly	1
2	232-639-00	Intermediate Plumbing Assembly Hook 1	1
3	232-626-10	Single Master Cylinder Assembly	1
4	560-012-00	Dust Cap*	1
5	560-013-00	Dust Cap*	1

*Not illustrated

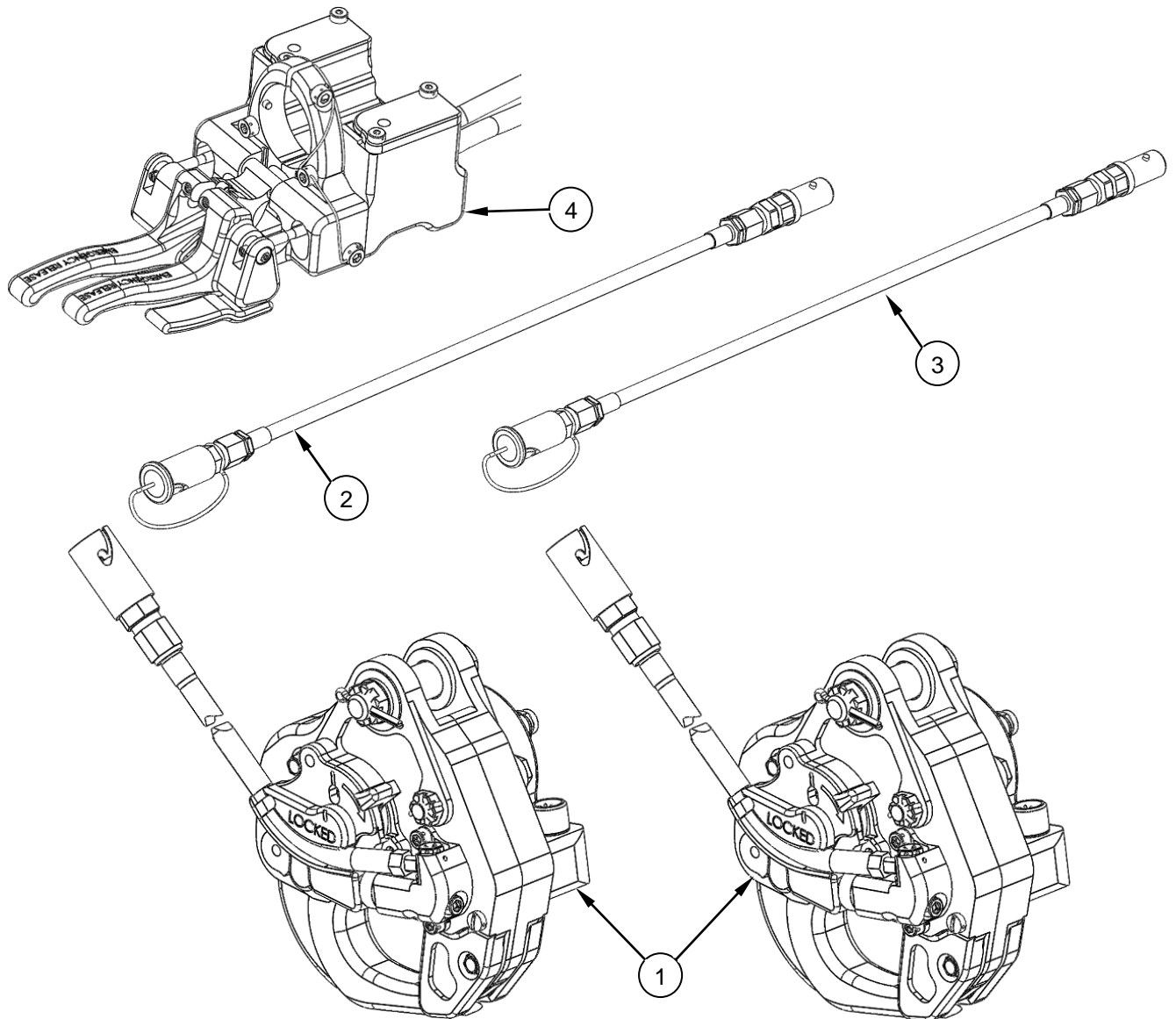

Figure 8.2 AH Common Beam External Cargo Handling System - Dual Hook EC145T2

Table 8.2 AH Common Beam External Cargo Handling System - Dual Hook

Item	P/N	Description	Qty
1	232-637-00	Cargo Hook Slave Cylinder Assembly	2
2	232-638-00	Intermediate Plumbing Assembly Hook 2	1
3	232-639-00	Intermediate Plumbing Assembly Hook 1	1
4	232-626-11	Dual Master Cylinder Assembly	1
5	560-012-00	Dust Cap*	2
6	560-013-00	Dust Cap*	2

*Not illustrated

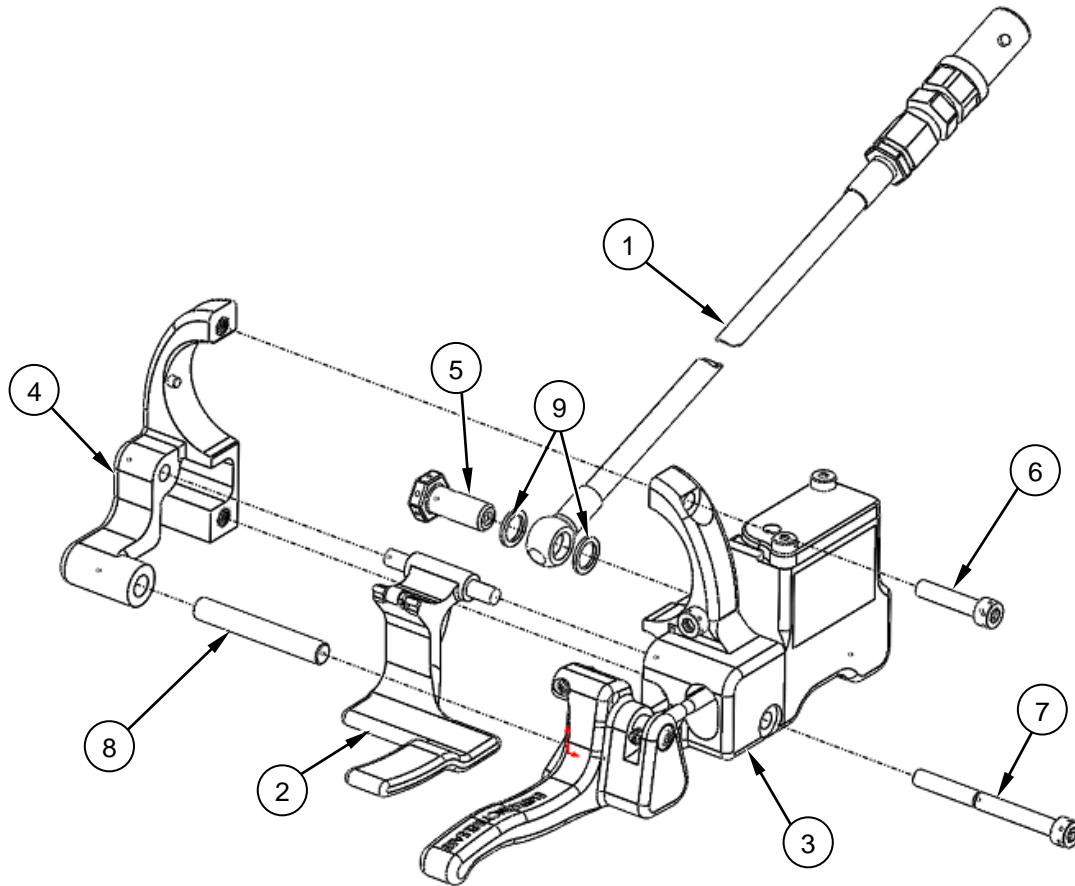

Figure 8.3 Single Master Cylinder Assembly P/N 232-626-10

Table 8.3 Single Master Cylinder Assembly P/N 232-626-10

Item	P/N	Description	Qty
1	232-632-00	Master Cylinder Plumbing Assembly Hook 1 & 2	1
2	232-640-00	Lockout Lever Assembly	1
3	232-641-10	Master Cylinder Subassembly (Port)	1
4	232-642-10	Master Cylinder Clamp	1
5	291-665-00*	Banjo Bolt, Drilled Head	1
6	511-080-00	Socket Head Screw	1
7	511-081-00	Socket Head Screw	1
8	511-085-00	Dowel Pin	1
9	556-040-00	Crush Washer	2

*For Master Cylinder Assemblies identified as Amdt. B, the banjo bolt P/N is 291-665-01, refer to Service Bulletin 159-048-00.

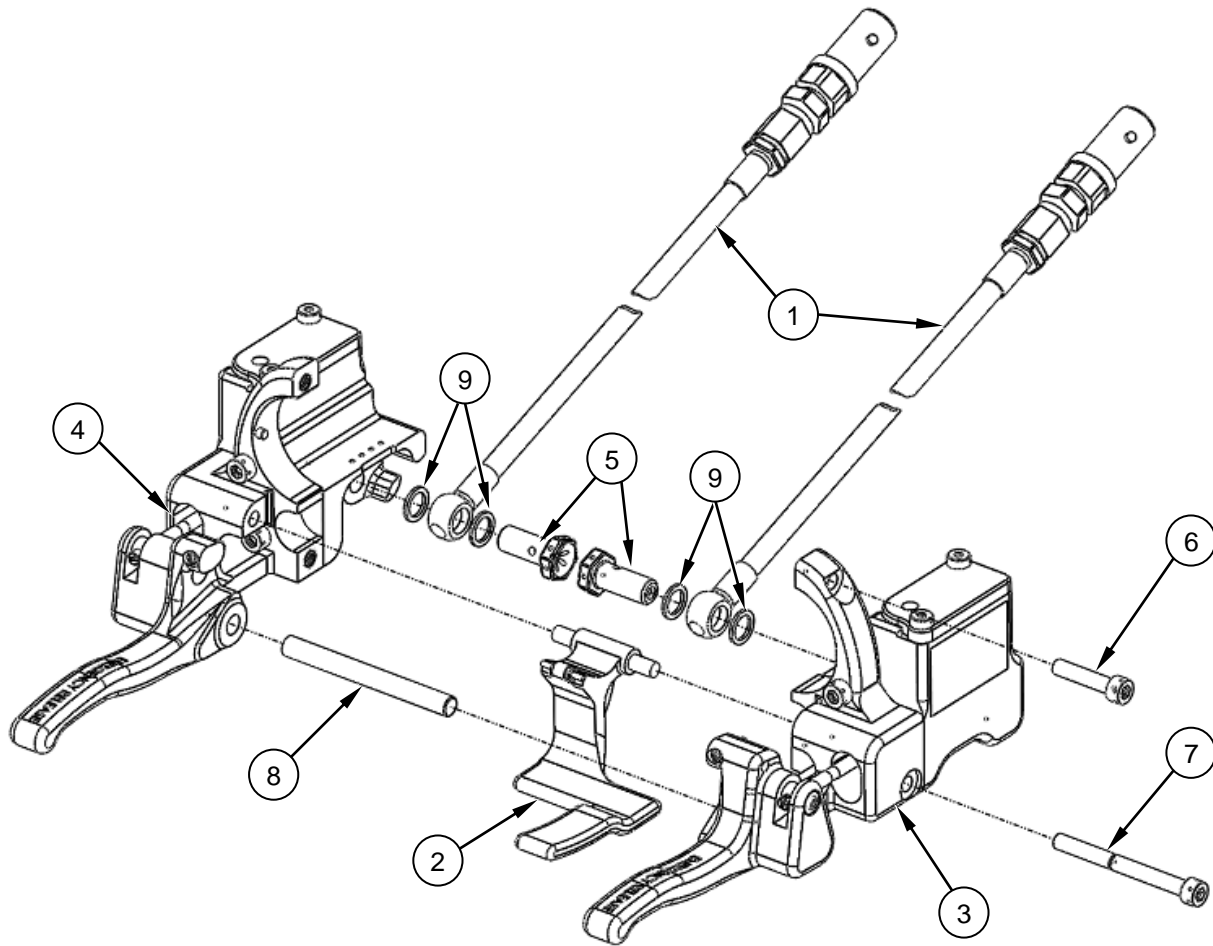

Figure 8.4 Dual Master Cylinder Assembly P/N 232-626-11

Table 8.4 Dual Master Cylinder Assembly P/N 232-626-11

Item	P/N	Description	Qty
1	232-632-00	Master Cylinder Plumbing Assembly Hook 1 & 2	2
2	232-640-00	Lockout Lever Assembly	1
3	232-641-10	Master Cylinder Subassembly (Port)	1
4	232-643-10	Master Cylinder Subassembly (Stbd)	1
5	291-665-00*	Banjo Bolt, Drilled Head	2
6	511-080-00	Socket Head Screw	1
7	511-081-00	Socket Head Screw	1
8	511-086-00	Dowel Pin	1
9	556-040-00	Crush Washer	4

*For Master Cylinder Assemblies identified as Amdt. B, the banjo bolt P/N is 291-665-01, refer to Service Bulletin 159-048-00.

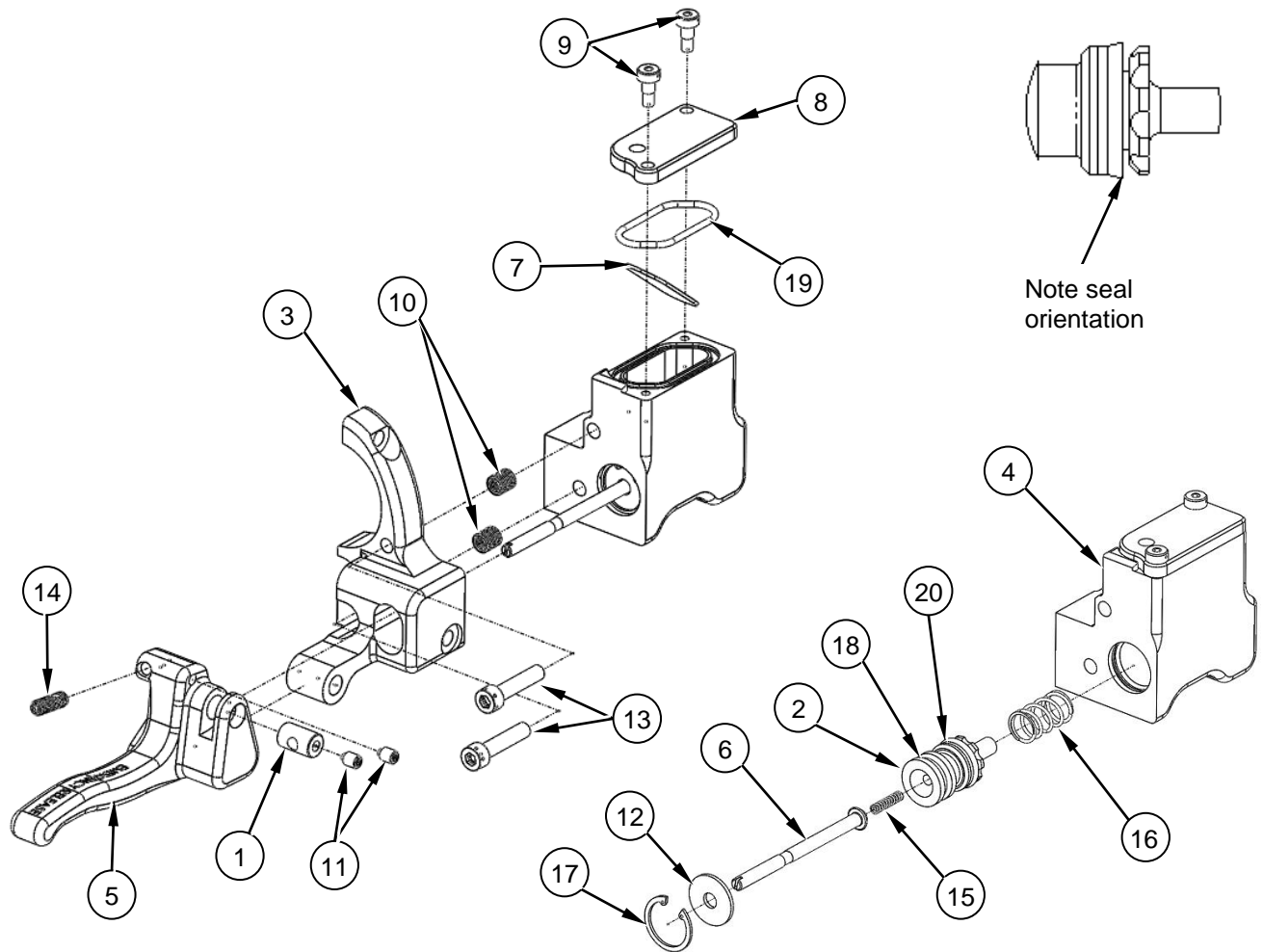

Figure 8.5 Master Cylinder Sub Assembly – Port P/N 232-641-10

	Owner's Manual Airbus Helicopters Common Beam EC145T2	Document Number 120-217-00	Revision 8
		Date 07/15/21	Page 41 of 48

Table 8.5 Master Cylinder Sub Assembly – Port P/N 232-641-10

Item	P/N	Description	Qty
1	290-812-00	Barrel Nut	1
2	290-814-01	Piston	1
3	291-831-00	Dual Cylinder Clamp (Port)	1
4	291-836-00	Dual Master Cylinder (Port)	1
5	291-838-00	Lever (Port)	1
6	291-842-00	Push Rod	1
7	291-851-00	Baffle Plate	1
8	291-852-00	Reservoir Lid	1
9	511-124-00	Shoulder Screw - Drilled Head	2
10	510-248-00	Helicoil	2
11	510-530-00	Set Screw	2
12	510-532-00	Washer	1
13	511-080-00	Socket Head Screw	2
14	511-109-00	Ball Nose Spring Plunger	1
15	514-060-00	Spring	1
16	514-118-00	Spring	1
17	515-008-00	Snap Ring	1
18	556-047-00	O-Ring	1
19	556-105-00	O-Ring	1
20	556-048-00	Cup Seal	1

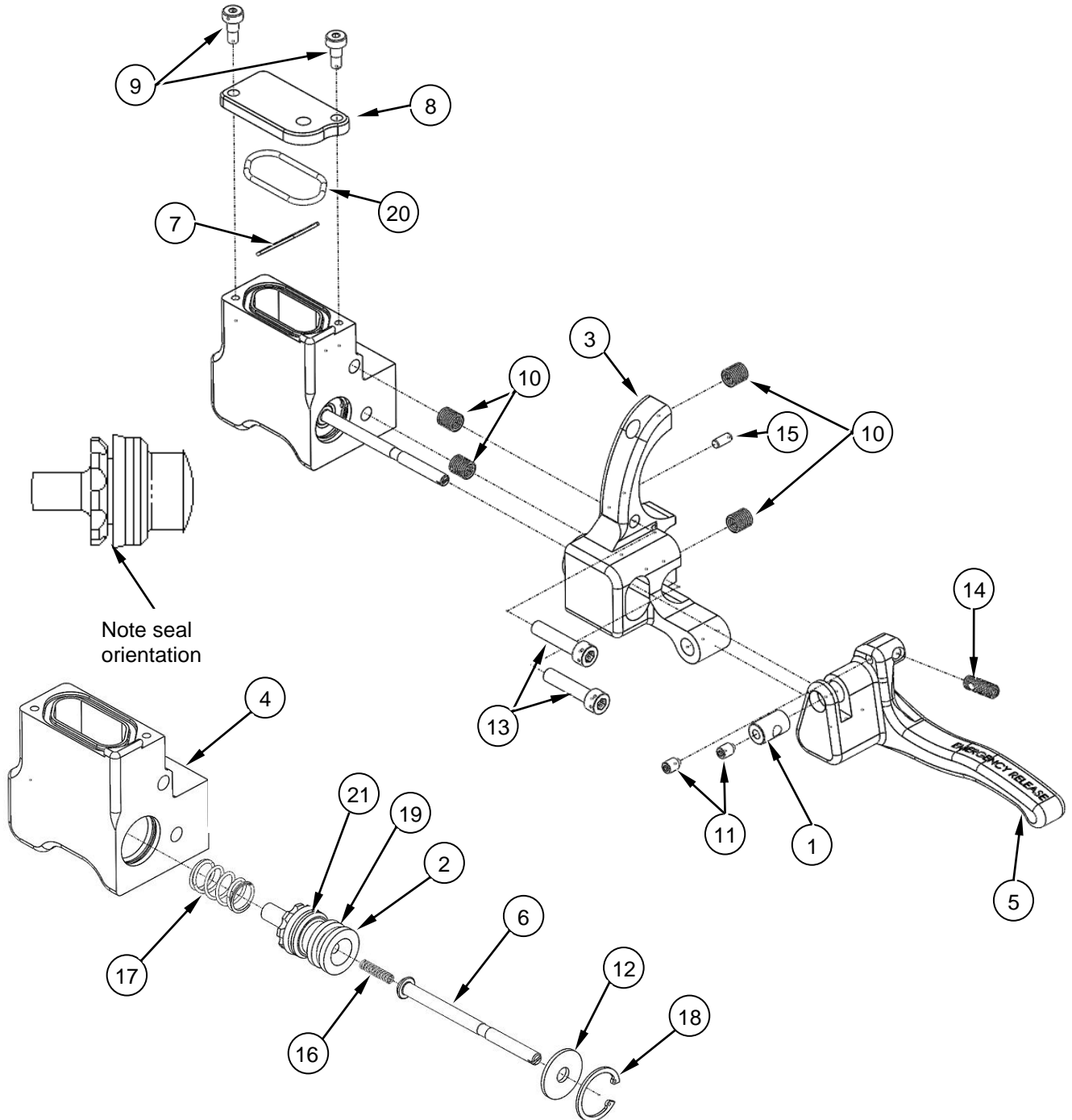

Figure 8.6 Master Cylinder Subassembly – Starboard P/N 232-643-10



	Owner's Manual Airbus Helicopters Common Beam EC145T2	Document Number 120-217-00	Revision 8
		Date 07/15/21	Page 43 of 48

Table 8.6 Master Cylinder Subassembly – Starboard P/N 232-643-10

Item	P/N	Description	Qty
1	290-812-00	Barrel Nut	1
2	290-814-01	Piston	1
3	291-832-00	Dual Cylinder Clamp (Starboard)	1
4	291-837-00	Dual Master Cylinder (Starboard)	1
5	291-839-00	Lever (Starboard)	1
6	291-842-00	Push Rod	1
7	291-851-00	Baffle Plate	1
8	291-852-00	Reservoir Lid	1
9	511-124-00	Shoulder Screw - Drilled Head	2
10	510-248-00	Helicoil	4
11	510-530-00	Set Screw	2
12	510-532-00	Washer	1
13	511-080-00	Socket Head Screw	2
14	511-109-00	Ball Nose Spring Plunger	1
15	511-087-00	Dowel Pin	1
16	514-060-00	Spring	1
17	514-118-00	Spring	1
18	515-008-00	Snap Ring	1
19	556-047-00	O-Ring	1
20	556-105-00	O-Ring	1
21	556-048-00	Cup Seal	1

	Owner's Manual Airbus Helicopters Common Beam EC145T2	Document Number 120-217-00	Revision 8
		Date 07/15/21	Page 44 of 48

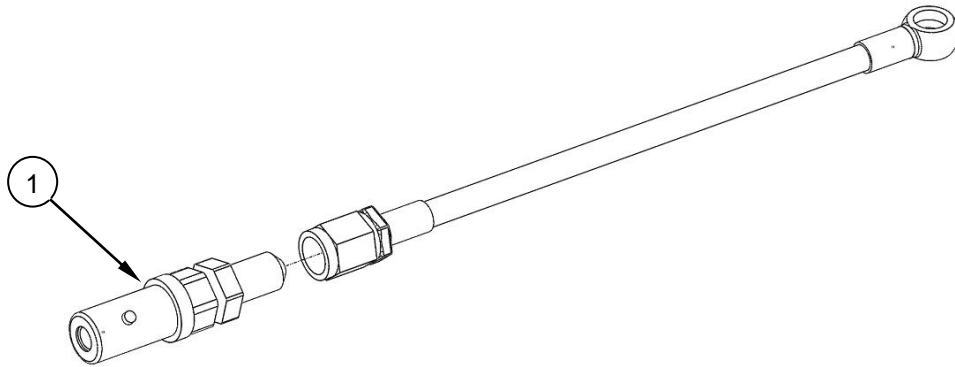

Figure 8.7 Master Cylinder Plumbing Assembly – Hook 1 & 2 P/N 232-632-00

Table 8.7 Master Cylinder Plumbing Assembly – Hook 1 & 2 P/N 232-632-00

Item	P/N	Description	Qty
1	560-005-00	Dry Break Coupler	1
2	560-013-00	Dust Cap*	1

*Not illustrated

The remaining elements of the 232-632-00 assembly are not serviceable.

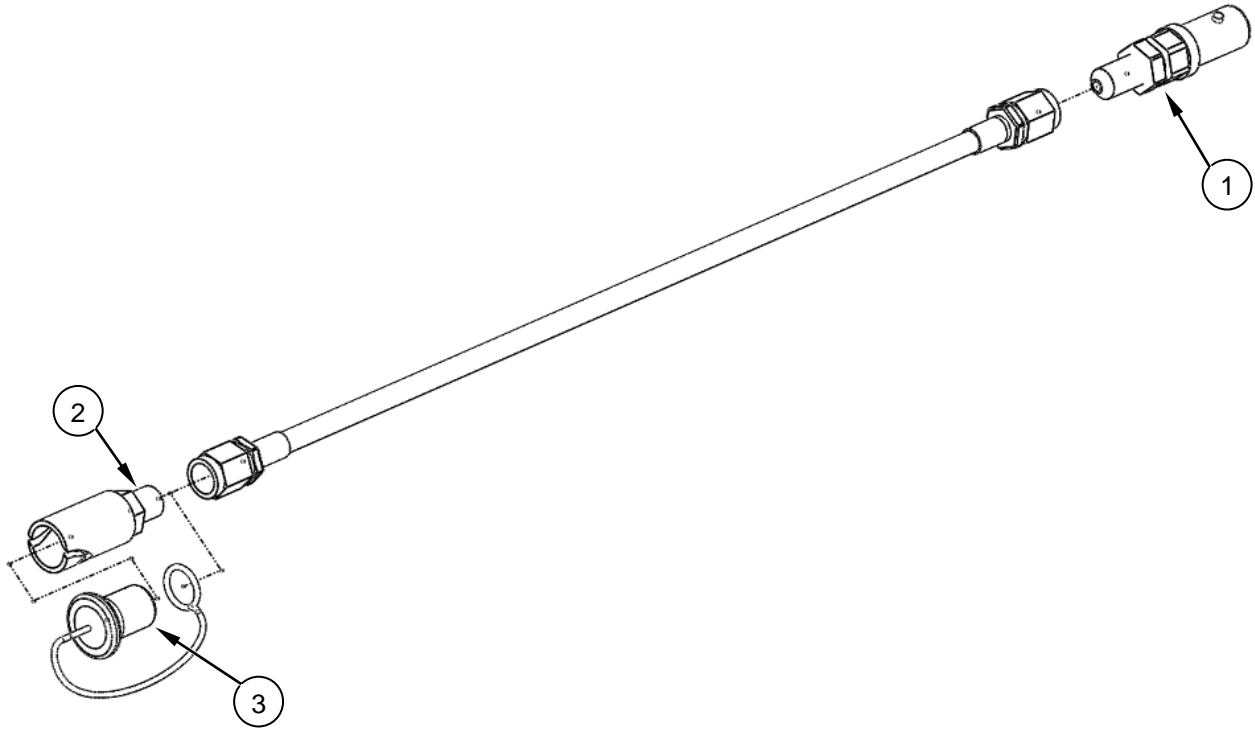

Figure 8.8 Intermediate Plumbing Assembly - Hook 1 P/N 232-639-00 & Hook 2 P/N 232-638-00

Table 8.8 Intermediate Plumbing Assembly - Hook 1 P/N 232-639-00 & Hook 2 P/N 232-638-00

Item	P/N	Description	Qty
1	560-005-00	Dry Break Coupler	1
2	560-006-00	Dry Break Coupler	1
3	560-012-00	Dust Cap	1

The remaining elements of the 232-639-00 assembly are not serviceable.

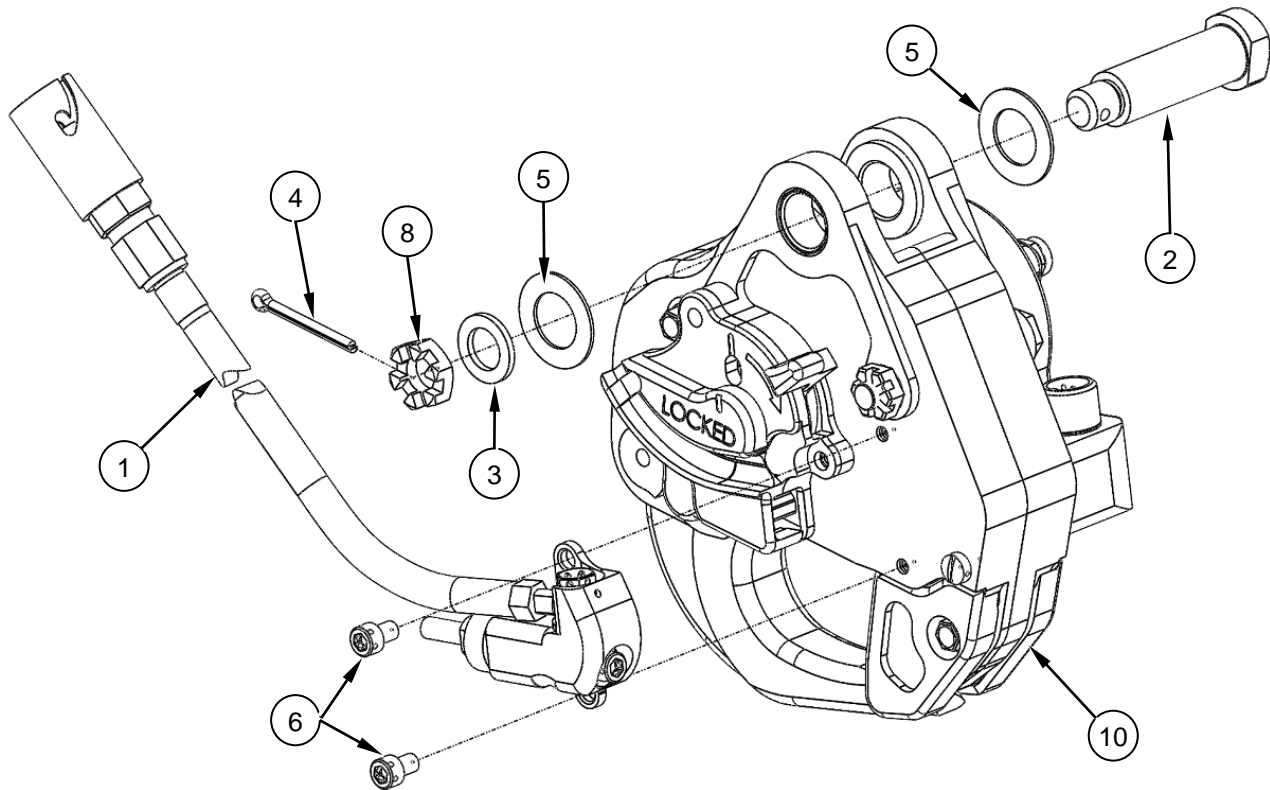

Figure 8.9 Cargo Hook/Slave Cylinder Assembly P/N 232-637-00

Table 8.9 Cargo Hook/Slave Cylinder Assembly P/N 232-637-00

Item	P/N	Description	QTY
1	232-634-00	Slave Cylinder With Plumbing	1
2	290-332-00	Attach Bolt	1
3	510-174-00	Washer	1
4	510-178-00	Cotter Pin	1
5	510-183-00	Washer	2
6	510-531-00	Screw	2
7	510-755-00	Screw	1
8	510-780-00	Nut	1
9	512-011-00	Cable Tie	1
10	528-028-55	Cargo Hook*	1

*See Component Maintenance Manual 122-015-00 for Cargo Hook illustrated parts list

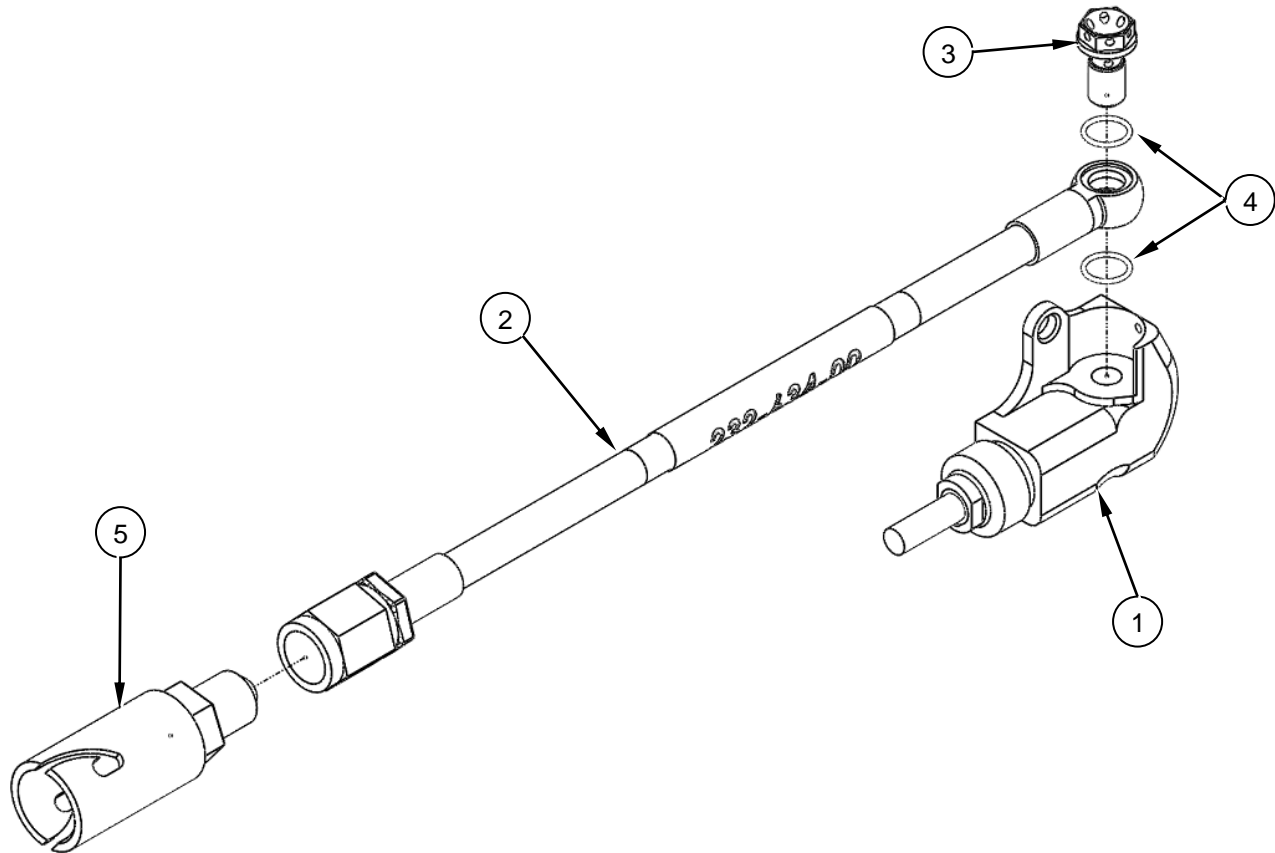

Figure 8.10 Slave Cylinder With Plumbing P/N 232-634-00

Table 8.10 Slave Cylinder With Plumbing P/N 232-634-00

ITEM	P/N	Description	QTY
1	232-169-01	Slave Cylinder Assembly	1
2	232-635-00	Slave Cylinder Plumbing Assembly	1
3	558-031-00	Banjo Bolt	1
4	556-041-00	O-Ring	2
5	560-006-00	Dry Break Coupler	1

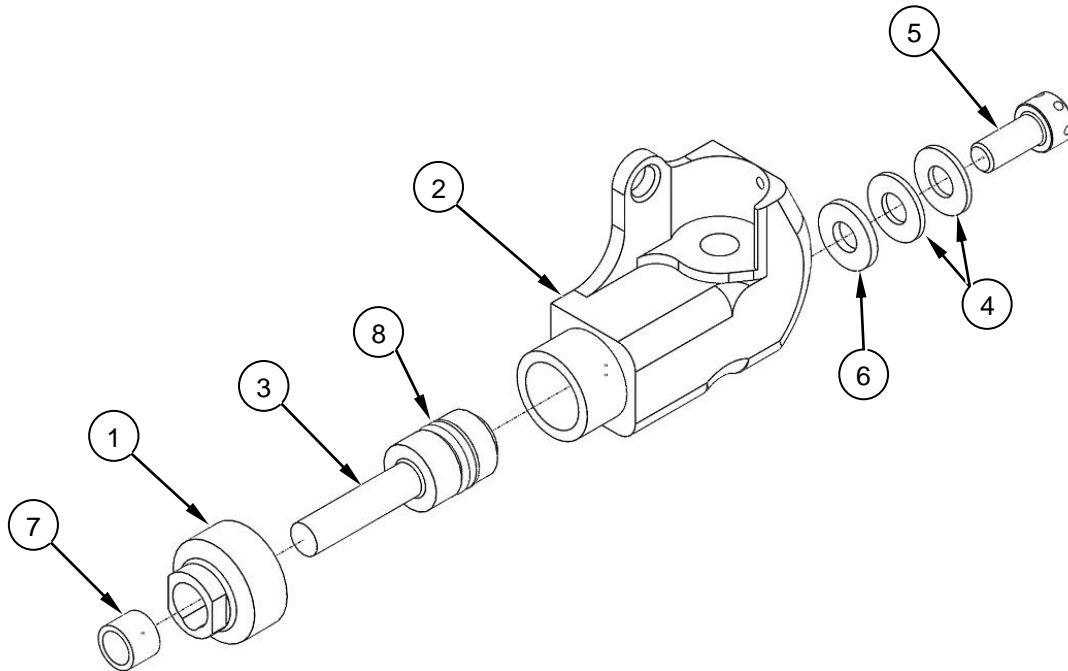

Figure 8.11 Slave Cylinder Assembly P/N 232-169-01

Table 8.11 Slave Cylinder Assembly P/N 232-169-01

ITEM	P/N	Description	QTY
1	290-802-00	Slave Cylinder Cap	1
2	290-803-00	Slave Cylinder	1
3	290-805-00	Piston	1
4	510-209-00	Washer	2
5	510-694-00	Screw	1
6	510-740-00	Threadseal	1
7	517-040-00	DU Bushing	1
8	556-097-00	Quad Ring	1