

**PLEASE CHECK WEB SITE AT WWW.ONBOARDSYSTEMS.COM FOR THE LATEST REVISION OF THIS MANUAL**

**FAA APPROVED  
ROTORCRAFT FLIGHT MANUAL  
SUPPLEMENT**

***Cargo Hook Sling Suspension System  
Retrofit Kit***

***STC SR01394SE***

***Airbus Helicopter Models  
AS350B, AS350B1, AS350B2,  
AS350B3, AS350BA, and AS350D***

**R/N \_\_\_\_\_ S/N \_\_\_\_\_**

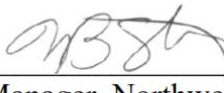
FAA Approved:  **ROBERT B STONEY**  
for/ **Manager, Northwest Flight Test Section, AIR-715  
Federal Aviation Administration  
Seattle, WA**

Digitally signed by ROBERT B STONEY  
Date: 2018.09.14 15:26:42 -07'00'

Date: 14 September 2018



<b>RFM Supplement</b>	Document Number 121-016-01	
	Page 1 of 17	Revision 1

### Record of Revisions

<b>Rev.</b>	<b>Date</b>	<b>Page(s)</b>	<b>Reason for Revision</b>
0	April 15, 2014	All	Initial Release
1	September 14, 2018	All	Updated limitations section including HEC limitation statement. General updates throughout.

	<b>RFM Supplement</b>	Document Number 121-016-01	Rev. 1
	<b>Cargo Hook</b>	Page 2 of 17	FAA approved 14 Sept 2018

## 1. General

This supplement must be attached to the appropriate FAA approved Airbus Helicopters Rotorcraft Flight Manual when an Onboard Systems 200-287-01 Cargo Hook Sling Suspension is installed in accordance with Supplemental Type Certificate (STC) NO. SR01394SE.

The information contained herein supplements or supersedes the basic manual only in those areas listed herein. For limitations, procedures and performance information not contained in this supplement, consult the basic Rotorcraft Flight Manual and “Cargo Sling” Flight Manual Supplement issued by Airbus Helicopters.

The 200-287-01 Cargo Hook Sling Suspension System is a retrofit kit that requires the presence of Airbus Helicopters cargo hook fixed provisions and is comprised of:

- A structural linkage (referred to as sling suspension) attached to the rotorcraft’s hard point on the forward fuel tank support. The sling suspension supports the cargo hook and swings in the direction of the external load.
- An electrical release system that provides means for release by pilot actuation of a pushbutton switch on the cyclic. The system interfaces with the rotorcraft’s electrical release mission selector and release pushbutton switch installed by Airbus Helicopters.
- A manual release system, which provides an additional means of releasing a cargo hook load. The system interfaces with the rotorcraft’s internal manual release system (including the release lever on the collective) as installed by Airbus Helicopters.
- A load weigh system, which is comprised of an indicator mounted within the cockpit, a load cell at the cargo hook as part of the sling suspension, and the interconnecting wire harness.



**RFM Supplement**

Document Number  
121-016-01

Rev. 1

**Cargo Hook**

Page  
3 of 17

FAA approved  
14 Sept 2018

## 2 LIMITATIONS

The limitations specified in the basic flight manual and the Airbus Helicopters' "Cargo Sling" flight manual supplement remain applicable and are completed or modified by the following.

### Operating Limitations

With a load attached to the cargo hook, operation shall be conducted in accordance with the respective national operational requirements.

The cargo hook kit configurations (as installed per this STC SR01394SE) do not meet the 14 CFR part 27 certification requirements for Human External Cargo (HEC).

## NOTICE

*The cargo hook equipment certification approval does not constitute operational approval; operational approval for external load operations must be granted by the local Aviation Authority.*

### Airspeed Limitation

Consult the Airbus Helicopters' "Cargo Sling" flight manual supplement for maximum airspeed with external load. The operator must establish the maximum airspeed for each specific external load configuration.

### Cargo hook maximum load

The maximum load to be carried on the cargo sling is the lesser of that specified by the Airbus Helicopters' Cargo Sling Flight Manual Supplement or 1660 lbs (750 kg).



**RFM Supplement**

Document Number  
121-016-01

Rev. 1

**Cargo Hook**

Page  
4 of 17

FAA approved  
14 Sept 2018



**Placards**

The following placards are included with the 200-287-01 Cargo Hook Sling Suspension System.

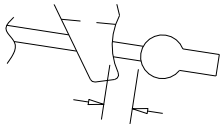
Adhered on the underside of the cargo hook electrical housing:

 <b>WARNING</b>	
Inadvertent loss of load can result from improper cable adjustment. See manual for complete instructions.	.13 in / 3.2 mm min

Attached around the manual release cable:

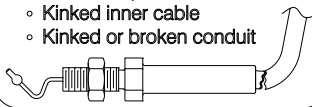
 <b>WARNING</b> <ul style="list-style-type: none"><li>Route to avoid strain</li><li>Rig with proper free play</li><li>Replace as condition requires (See reverse)</li><li>See manual for complete instructions</li></ul>	 <b>WARNING</b> <p>Causes for replacement:</p> <ul style="list-style-type: none"><li>Kinked inner cable</li><li>Kinked or broken conduit</li></ul> 
One Side	Opposite Side



**RFM Supplement**

Document Number  
121-016-01

Rev. 1

**Cargo Hook**

Page  
5 of 17

FAA approved  
14 Sept 2018

### 3 EMERGENCY PROCEDURES

The emergency procedures specified in the basic flight manual and the Airbus Helicopters' "Cargo Sling" flight manual supplement for the AS350 remain applicable.

	<b>RFM Supplement</b>	Document Number 121-016-01	Rev. 1
	<b>Cargo Hook</b>	Page 6 of 17	FAA approved 14 Sept 2018

#### 4. Normal Procedures

The normal procedures specified in the basic flight manual are applicable and are completed or modified by the following.

##### Pre-Flight Check

Before a flight involving external load operations perform the following procedures. If the procedures are not successful do not use the equipment until the problem has been corrected.

1. Swing the cargo hook and the suspension assembly to their full extremes to verify that the manual release cable and the electrical harnesses are not pulled tight in any position.
2. Visually check the external manual release cable for damage, paying close attention to the flexible conduit at the area of transition to the cargo hook end fitting (refer to Figure 4.1). Check for splitting of the outer black conduit in this area and separation of the conduit from the steel end fitting.

**Figure 4.1 Manual Release Cable Check**

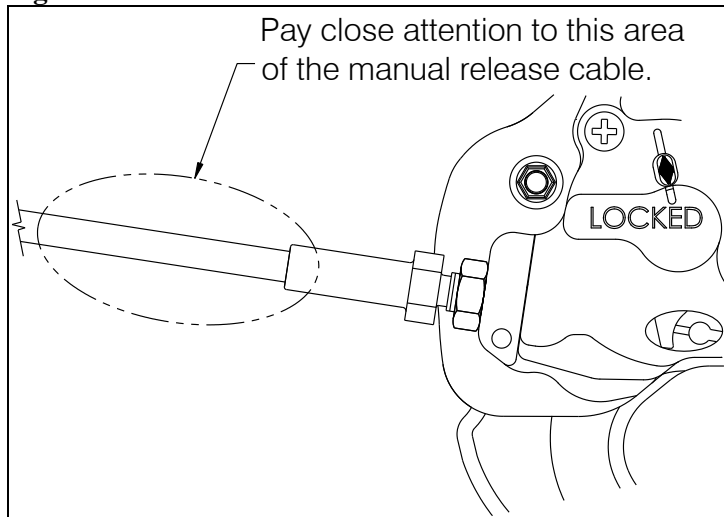

**Pre-Flight Check** continued

3. Cycle the manual release system to ensure proper operation. Pull the manual release lever on the collective. The cargo hook load beam must open. Return the cargo hook load beam to the locked position by manually pushing up on it. The load beam should snap shut. Verify that the hook lock indicator on the side of the hook returns to the fully locked position (see Figure 4.2).

**NOTICE**

*The cargo hook sling suspension interfaces with the manual release lever on the collective as supplied by Airbus Helicopters. Consult the Airbus Helicopters "Cargo Sling" Flight Manual Supplement for operation.*

**CAUTION**

*In the closed and fully locked position the hook lock indicator must align with the lines on the manual release cover (see Figure 4.2).*

**Figure 4.2 Hook Lock Indicator**

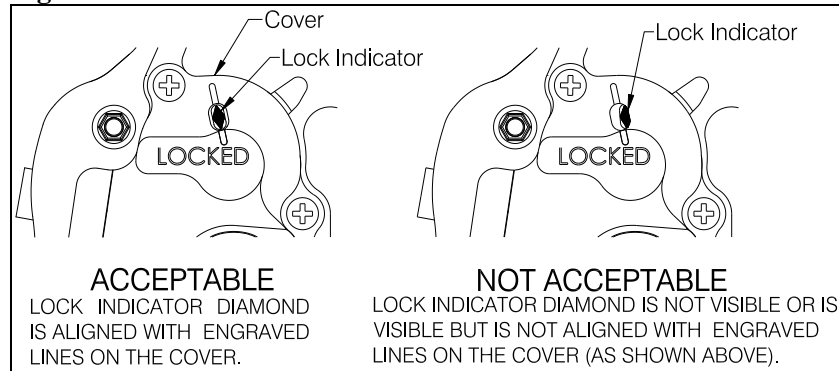

	<b>RFM Supplement</b>	Document Number 121-016-01	Rev. 1
	<b>Cargo Hook</b>	Page 8 of 17	FAA approved 14 Sept 2018



**Pre-Flight Check** continued

4. Cycle the electrical release system to ensure proper operation per the following. Arm the cargo hook electrical release system using the rotorcraft's SLING pushbutton. Press the CARGO REL pushbutton switch on the cyclic and ensure the cargo hook opens. Return the cargo hook load beam to the locked position by manually pushing up on it. The load beam should snap shut. Verify that the hook lock indicator on the side of the hook returns to the fully locked position (see Figure 4.2). The cargo hook may be flown in the open position to facilitate loading by a ground crew.

# NOTICE

*The cargo hook sling suspension interfaces with the rotorcraft's arming switch and release pushbutton switch as supplied by Airbus Helicopters. Consult the Airbus Helicopters "Cargo Sling" Flight Manual Supplement for operation of these components.*



**RFM Supplement**

Document Number  
121-016-01

Rev. 1

**Cargo Hook**

Page  
9 of 17

FAA approved  
14 Sept 2018

**Pre-Flight Check** continued

5. Check the manual release cable rigging through the window in the cargo hook manual release cover. With the cargo hook load beam closed and locked, rotate the manual release lever clockwise to remove the free play (the free play is taken up when the hook lock indicator begins to move, this is also readily felt as the lever rotates relatively easily for several degrees as the free play is taken up) and hold it in this position while checking the gap between the release lever fork and the cable ball end as shown below. Visually check that there is approximately a minimum gap of 1/8" (3.2 mm) as shown in Figure 4.3.

**Figure 4.3 Manual Release Cable Rigging**

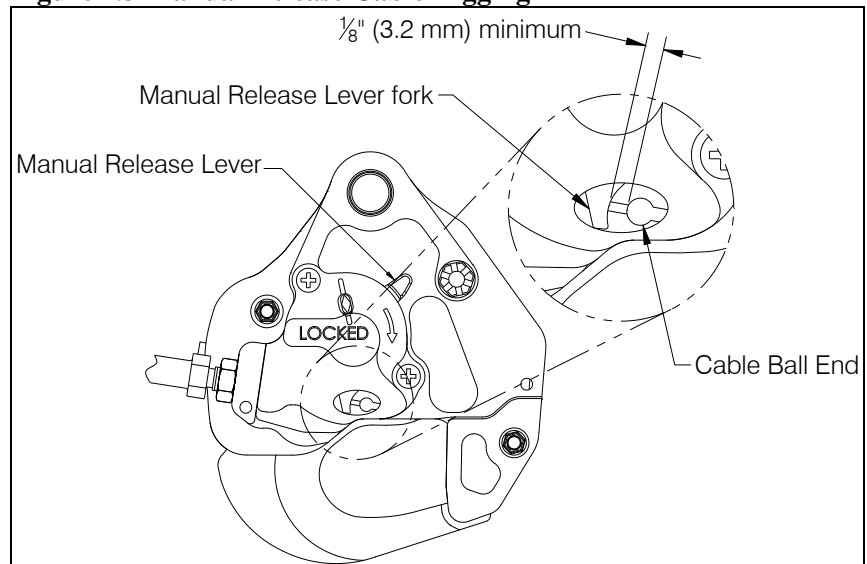

	<b>RFM Supplement</b>	Document Number 121-016-01	Rev. 1
	<b>Cargo Hook</b>	Page 10 of 17	FAA approved 14 Sept 2018

**Pre-Flight Check** continued

6. Power on the C-39 Indicator. After a brief self-diagnostic routine is complete the display should indicate “0” as shown below (with no load on the cargo hook).

**Figure 4.4 C-39 Indicator Display**

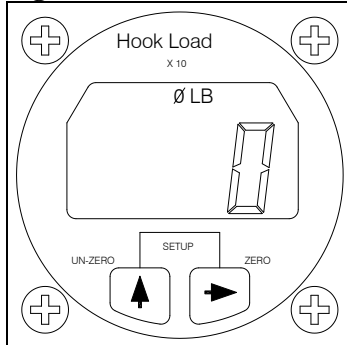

# NOTICE

*Refer to Owner's Manual 120-039-00 for setup instructions including changing the units, changing the calibration code, zeroing the display, changing the dampening level, etc.*



**RFM Supplement**

Document Number  
121-016-01

Rev. 1

**Cargo Hook**

Page  
11 of 17

FAA approved  
14 Sept 2018

### **Cargo Hook Rigging**

Extreme care must be exercised in rigging a load to the Cargo Hook. Figure 4.5 shows a recommended rigging configuration and rigging configurations to avoid.



*The configurations shown are not intended to represent all possibilities. It is the responsibility of the operator to assure the hook will function properly with the rigging.*



*Multiple load rings, nylon type straps (or similar material) or rope must not be used directly on the cargo hook load beam. If nylon straps or rope must be used they should be first attached to a steel primary ring. Verify that the ring will freely slide off the load beam when the cargo hook is opened. Only the primary ring should be in contact with the cargo hook load beam. See Figure 4.5.*

	<b>RFM Supplement</b>	Document Number 121-016-01	Rev. 1
	<b>Cargo Hook</b>	Page 12 of 17	FAA approved 14 Sept 2018

**Figure 4.5 Cargo Hook Rigging**

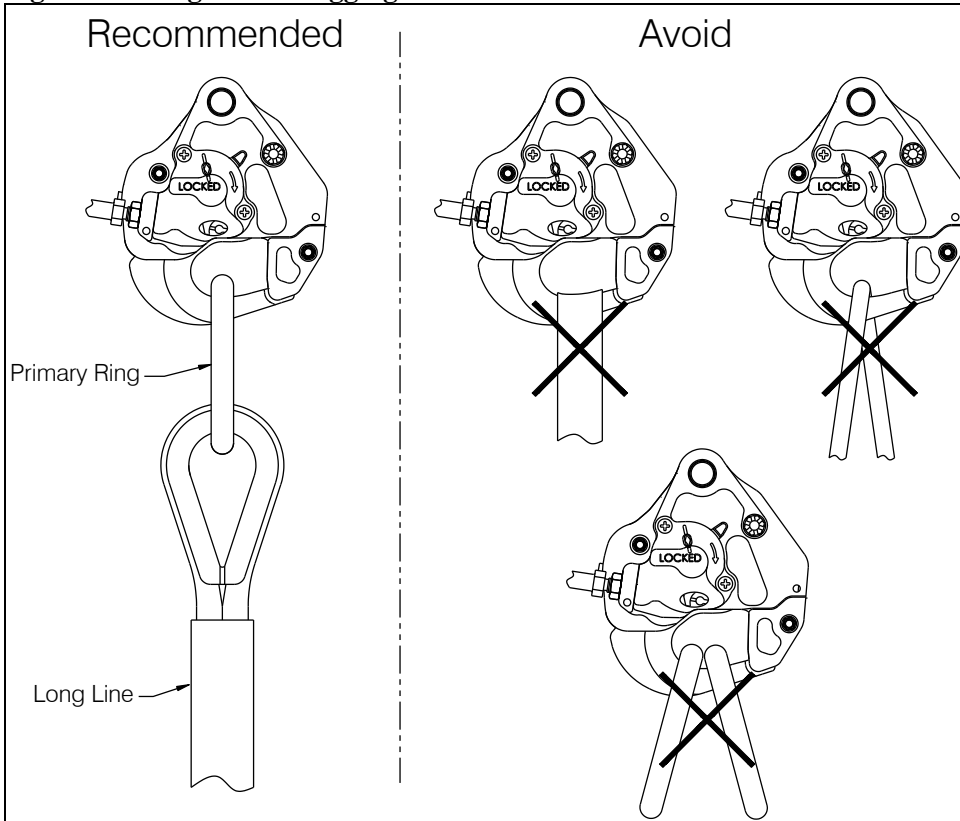

**RFM Supplement**

Document Number  
121-016-01

Rev. 1

**Cargo Hook**

Page  
13 of 17

FAA approved  
14 Sept 2018

Take-off

# CAUTION

*In wet weather, the ground operator should wear thick rubber gloves. Before attaching the load, discharge static electricity by placing a ground wire or tube between the cargo hook and ground.*

1. Following attachment of the external load, slowly increase the collective pitch and ascend vertically, maintaining the rotorcraft directly above the load. When the slack in the long line is removed, dwell briefly before lifting the load from the surface.
2. Check torque required to hover with the external load.
3. Check for adequate directional control.
4. Take off into the wind, if possible, and ensure clearance of the external load over obstacles.



**RFM Supplement**

Document Number  
121-016-01

Rev. 1

**Cargo Hook**

Page  
14 of 17

FAA approved  
14 Sept 2018

**In-flight**

Make all control movements gently with gradual acceleration and deceleration and only slightly banked turns.



*The suspension is designed to allow the cargo hook to pivot and align with the external load in all directions with limits to protect the electrical and mechanical release cables from damage. Take precautions to prevent external load angles which exceed the limits of rotation provided by the suspension as the load may not be releasable in this position.*

Maximum airspeed is dependent upon the size, weight, and shape of the external load and sling length. Closely observe the behavior of the load during flight and as airspeed is increased.



*Use caution when flying with an unloaded long line as this is an extreme snag hazard.*



**RFM Supplement**

Document Number  
121-016-01

Rev. 1

**Cargo Hook**

Page  
15 of 17

FAA approved  
14 Sept 2018

### Approach with and Release of External Load

1. Perform the approach at minimum rate of descent.
2. Execute the approach to hover with sufficient height to prevent the load from hitting obstacles on or being dragged along the ground and then slowly descend vertically to set the load on the ground.
3. Press the CARGO RELEASE switch on the cyclic to release the external load from the cargo hook.
4. The manual release lever on the collective is intended as a backup release in the event of an inability to release the load with the CARGO RELEASE switch but may be used to release the external load in normal circumstances.
5. Visually check to ensure that the external load has been released.



*Verify that the external load and long line has dropped free from the rotorcraft before departing the drop-site.*

	<b>RFM Supplement</b>	Document Number 121-016-01	Rev. 1
	<b>Cargo Hook</b>	Page 16 of 17	FAA approved 14 Sept 2018



## 5. Performance

The basic Flight Manual remains applicable when there is no external load attached.

When there is an external load, performance will be reduced depending on its size, weight and shape.

The Load Weigh System is intended as a means of MONITORING the weight of the load suspended from the Cargo Hook.

Before lifting a load, it is recommended that the load weight be estimated, the shape/size is considered and, upon lifting the load, monitor the load indicator and compare the actual engine torque value vs. the expected value for a given weight to verify sufficient performance.



**RFM Supplement**

Document Number  
121-016-01

Rev. 1

**Cargo Hook**

Page  
17 of 17

FAA approved  
14 Sept 2018