

**PLEASE CHECK WEB SITE AT WWW.ONBOARDSYSTEMS.COM FOR
THE LATEST REVISION OF THIS MANUAL**

Crew-Loc Hook

*Applicable Part Number:
210-302-00*

Owner's Manual

*Document number 120-223-00
Revision 0
March 24, 2017*



*13915 N. W. 3rd Court Vancouver Washington 98685 USA
Phone: 360-546-3072 Fax: 360-546-3073 Toll Free: 800-275-0883
www.OnboardSystems.com*

RECORD OF REVISIONS

<i>Revision</i>	<i>Date</i>	<i>Page(s)</i>	<i>Reason for Revision</i>
0	03/24/17	All	First Issue

Register Your Products for Automatic Notifications

Onboard Systems offers a free notification service via fax or email for product alerts and documentation updates. By registering your Onboard Systems products at our website, we will be able to contact you if a service bulletin is issued, or if the documentation is updated.

You can choose to receive notices on an immediate, weekly, or monthly schedule via fax, email or both methods. There is no charge for this service. Please visit our website at www.onboardsystems.com/notify.php to get started.

CONTENTS

***Section 1* General Information**

Introduction, 1-1
Explanation of Signal Words and Symbols, 1-2
Specifications, 1-3
Theory of Operation, 1-3

***Section 2* Installation Instructions**

***Section 3* Operation Instructions**

Crew-Loc Hook Operating Procedures, 3-1
Crew-Loc Hook Rigging, 3-2

***Section 4* Maintenance**

Storage Instructions, 4-1
Preventive Maintenance, 4-1
Inspection, 4-2
Crew-Loc Hook Disassembly Procedure, 4-2
Crew-Loc Hook Assembly Procedures, 4-3
Acceptance Test Procedures, 4-4
Crew-Loc Hook Exploded View, 4-5
Crew-Loc Hook Parts, 4-6
Instructions for Returning a System to the Factory, 4-7

Section 1

General Information

Introduction

The Crew-Loc Hook (P/N 210-302-00) is a swiveling load attachment device rated for 6,000 lbs. (2722 kg). The Crew-Loc Hook is particularly suited to non-repetitive long line lifts where security of the load is paramount and detachment of the load can be accomplished by ground crew.

Explanation of Signal Words and Symbols

The following definitions apply to the symbols used throughout this manual to draw the reader's attention to safety instructions as well as other important messages.



Indicates a hazardous situation which, if not avoided, will result in death or serious injury.



Indicates a hazardous situation which, if not avoided, could result in death or serious injury.



Indicates a hazardous situation which, if not avoided, could result in minor or moderate injury.



Draws the reader's attention to important or unusual information not directly related to safety.



Used to address practices not related to personal injury.

Specifications

Table 1-1 Crew-Loc Hook (P/N 210-302-00) Specifications

Design Load	6,000 lbs. (2722 kg)
Limit Load	15,000 lbs. (6,804 kg)
Design Ultimate Strength	22,500 lbs. (10,206 kg)
Unit weight	15 lbs. (6.8 kg)

Theory of Operation

The primary elements of the Crew-Loc Hook are the Snap Hook, Release Lever, Cage, and Swivel Housing (shown in figure following).

To attach or detach a load, the release lever is depressed and the Load Beam Hook is rotated up and outwards. With a load applied, the device is self-locking.

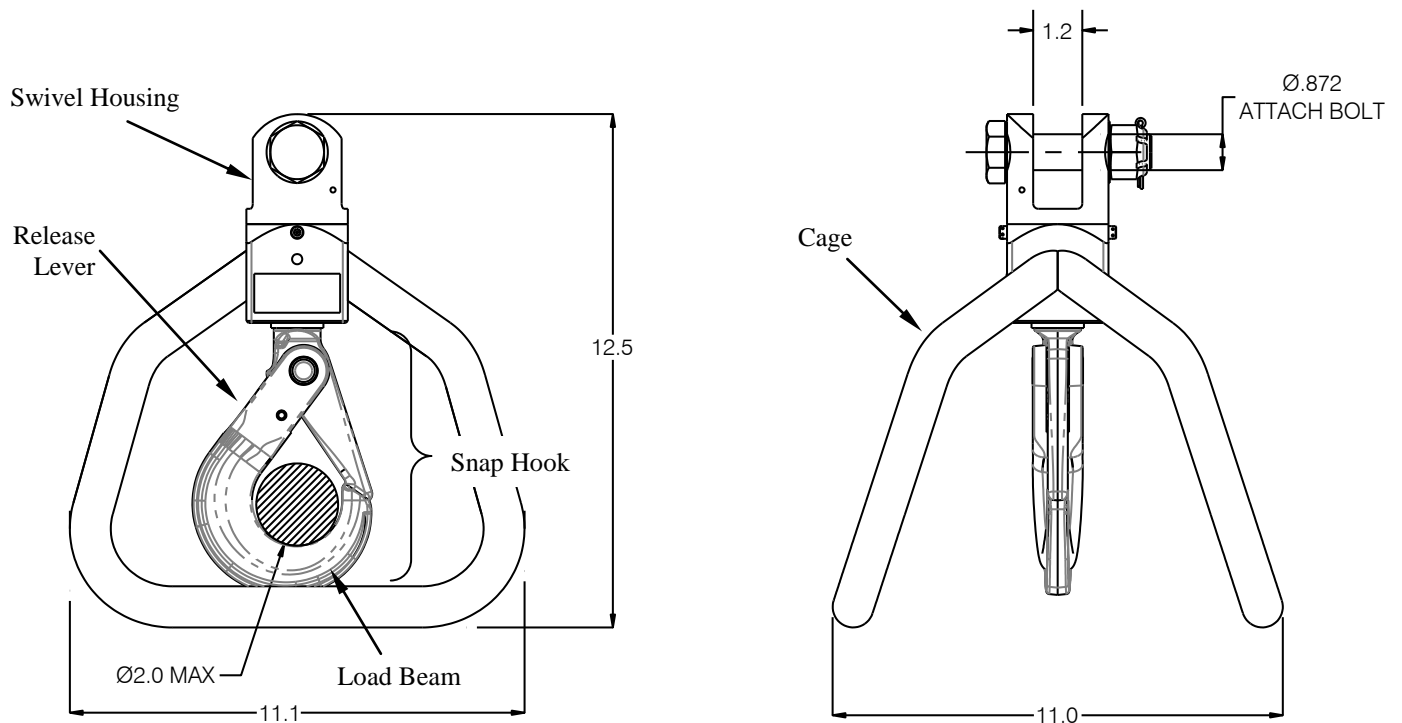

Figure 1-1 Crew-Loc 210-302-00 Major Components

Section 2

Installation Instructions

Inspect the Crew-Loc Hook for evidence of damage, corrosion and security of fasteners before installation. If damage is evident, do not use the unit until it has been repaired.

Attach the Crew-Loc Hook to a long line by placing the long line's thimble directly into the clevis of the Crew-Loc Hook—an anchor shackle or other attachment hardware is not required. Insert the attach bolt and secure with the provided washers and castellated nut as shown in Figure 2-1. Tighten the nut finger tight, then rotate to next castellation and install cotter pin.

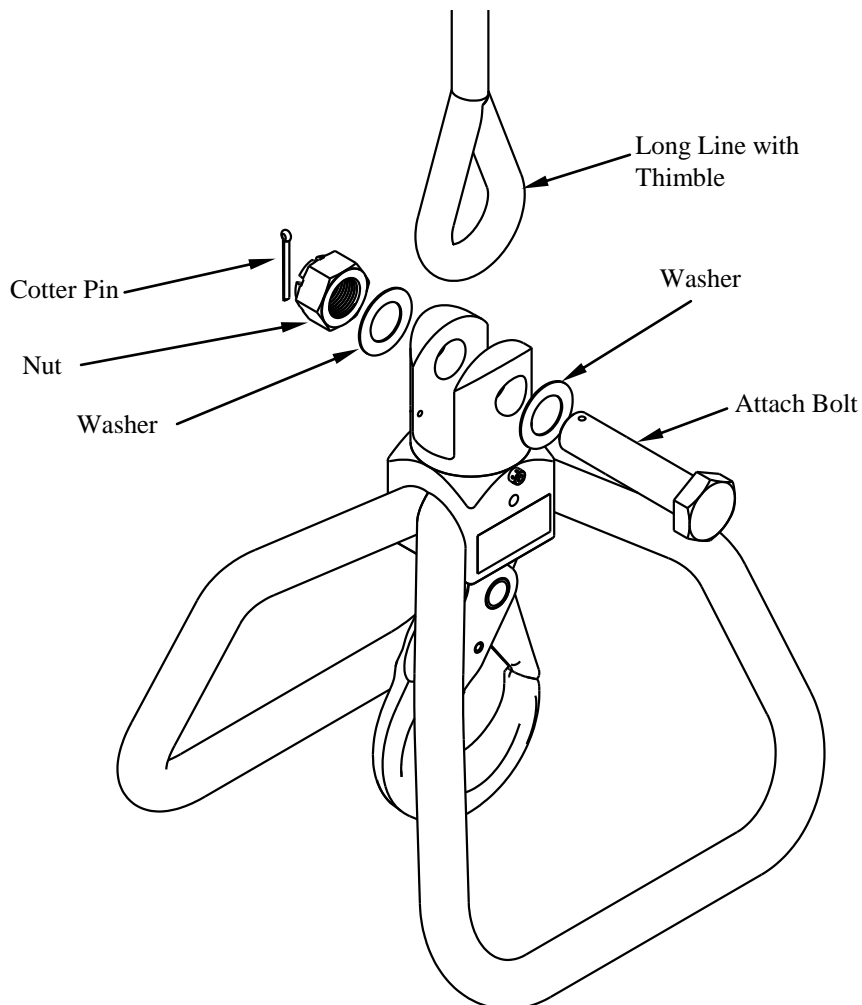

Figure 2-1 Installation

Section 3

Operation Instructions

Crew-Loc Hook Operating Procedures



The Crew-Loc Hook is not pilot-operable. Ground crew must be available to load and unload.

Loads are released by manually depressing the release lever on the Crew-Loc Hook and either lifting off the rigging or manually rotating the load beam upwards. (Loads will not drop by simply depressing the release lever). The Crew-Loc Hook is latched by rotating the load beam downward. The release lever will engage with a snapping action.

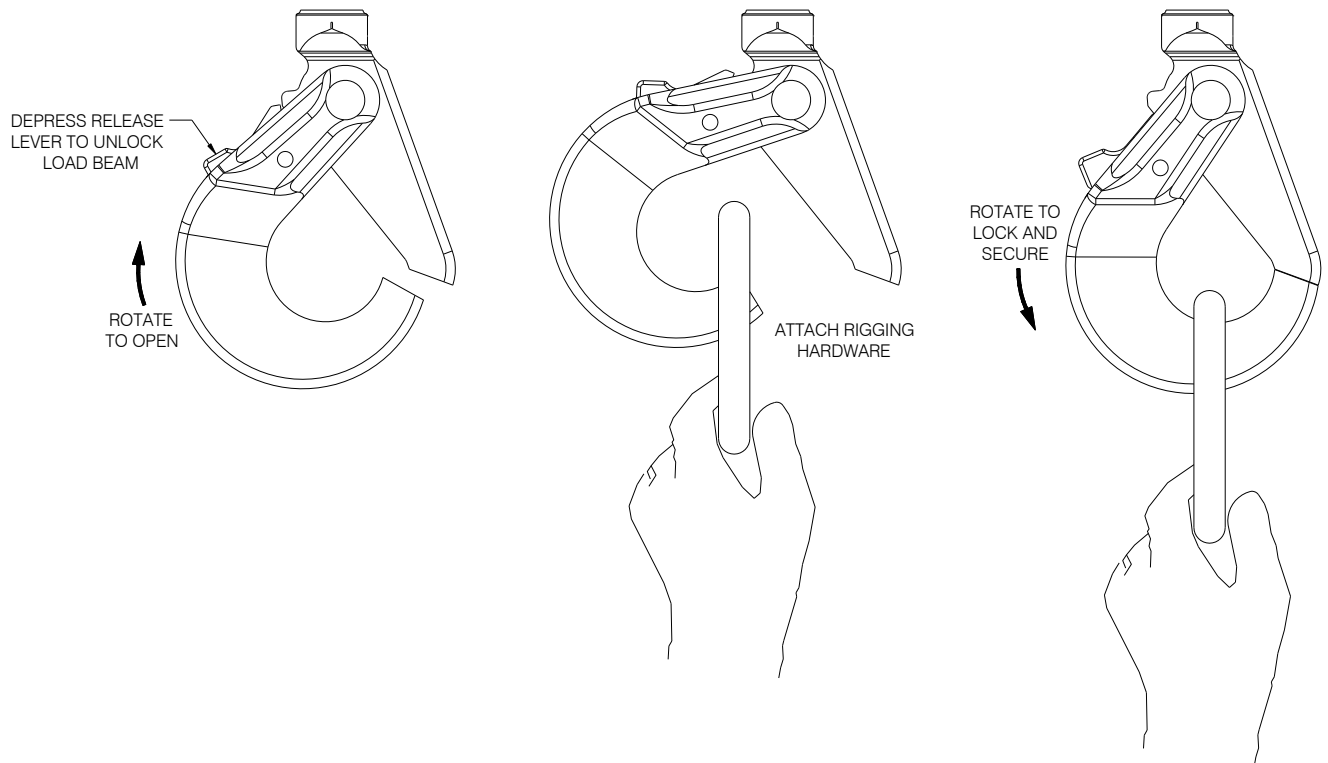

Figure 3-1 Rigging Installation

Crew-Loc Hook Rigging

Care must be exercised in rigging a load to the Crew-Loc Hook. Rigging precautions are shown in Figure 3-2 below.



It is the responsibility of the operator to ensure the hook will function properly with each individual rigging configuration.

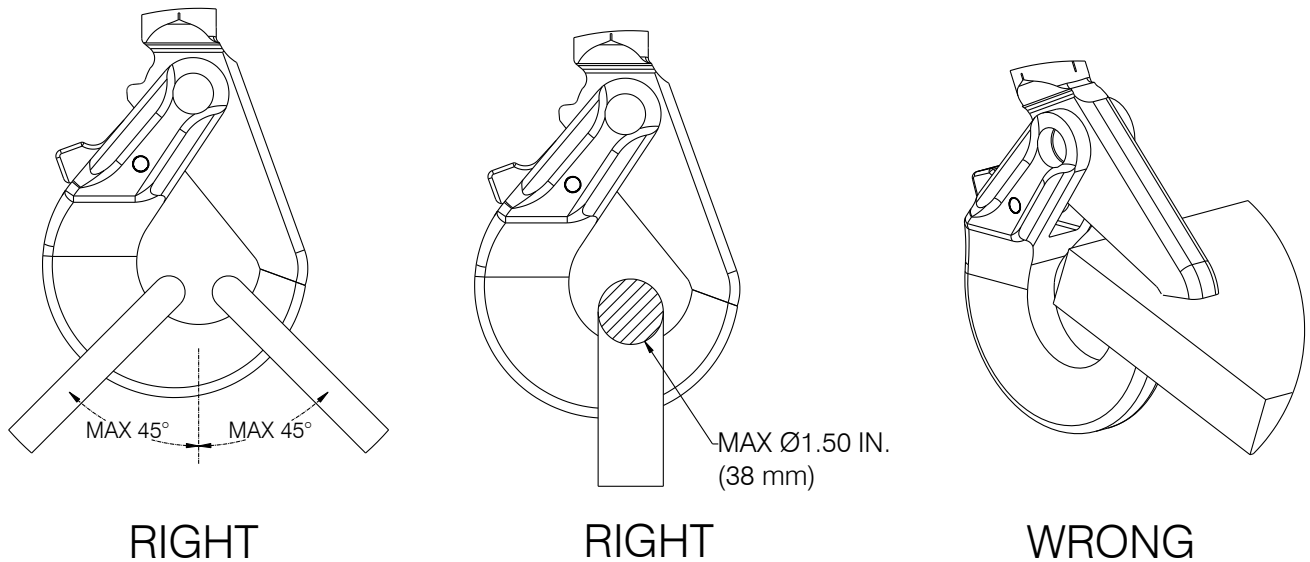

Figure 3-2 Rigging Precautions

Section 4

Maintenance

Storage Instructions

Clean the Crew-Loc Hook thoroughly before packaging. Pack the unit in a sealable package.

Place the sealed package in a suitable fiberboard box and cushion the unit to prevent shifting. Seal the fiberboard box with tape and mark the box with the contents and date of packaging.

If the unit is to be stored for long periods in a tropical climate it should be packed in a reliable manner to suit local conditions.

Preventive Maintenance

Remove caked-on dirt from the Crew-Loc Hook with a brush and clean exposed surfaces with a mild solvent. Thoroughly dry all surfaces. Periodic lubrication of the swivel is recommended to prevent premature wear and to ensure proper swivel function. Using Mobilgrease 28 or equivalent, lubricate assembly using the grease fitting.

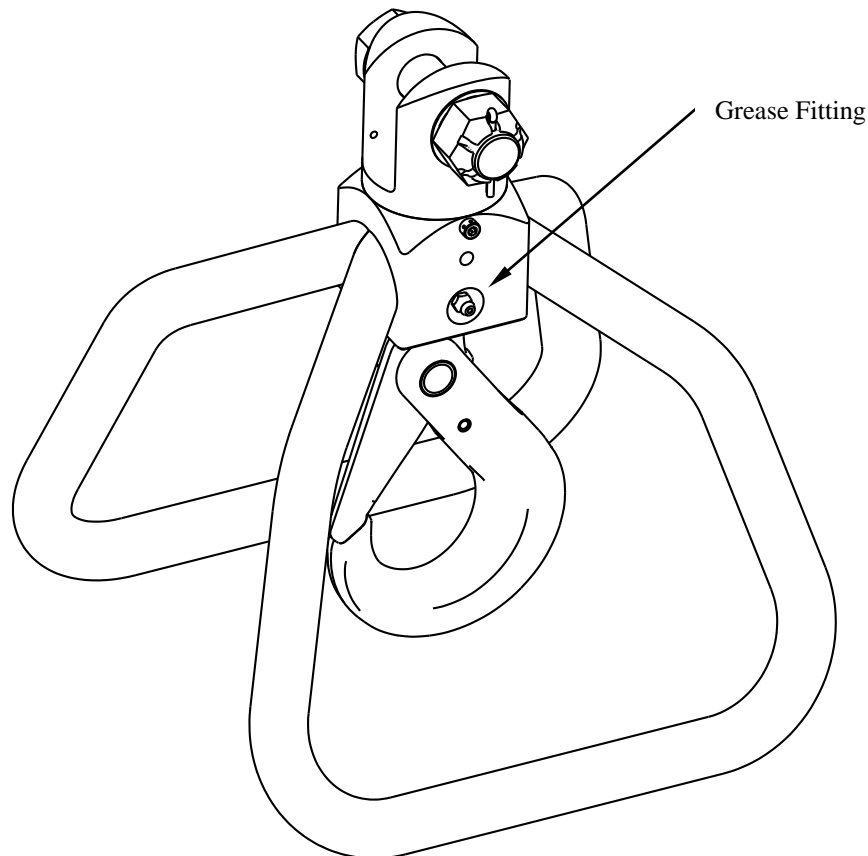

Figure 4-1 Grease Fitting

Inspection

Inspect the Crew-Loc Hook in accordance with the table below.

Table 4-1 Inspection

Daily Check	Inspection – Annually or 100 hours of external load operations, whichever comes first.
1. Inspect all fasteners to ensure that they are in place and secure. 2. Inspect the case and weldment for cracks and damage. 3. Inspect the load beam for gouges and cracks. 4. Swivel Crew-Loc hook 360° to ensure proper function. 5. Depress release lever to open Crew-Loc hook and check for proper function.	Same as daily check.

Crew-Loc Hook Disassembly Procedure

See Figure 4-2 for illustration and item numbers.

1. Remove the cotter pin (5) from the nut (8). Remove the bolt (7) and washers (9).
2. Remove the safety wire connecting the swivel top (3) and weldment (2).
3. Remove the set screws (6) from the weldment (2).
4. Remove the swivel top (3) from the weldment (2). It may be necessary to heat the assembly to free up the locking compound on the threads.
5. Remove the roll pin (10) from the castle nut (4). The roll pin may be accessed by pushing a punch through the RTV silicone in the hole just below the set screw hole.
6. Remove the castle nut from the load beam assembly (14).
7. Carefully remove the load beam assembly (14) from the weldment (2).
8. Remove the bearing (11) from the weldment and the felt washer (13) from the hook assembly.

Crew-Loc Hook Assembly Procedures

1. Replace all parts found to be damaged with serviceable parts.
2. Pack Mobilgrease 28 into the thrust ball bearing (11) completely filling the spaces between the balls.
3. Place the Bearing Seal Felt washer (13) over the end of the hook shaft. Apply a small amount of Mobilgrease 28 on the bottom surface of the bearing housing where the washer will contact it.
4. Insert the hook shaft up through the bottom of the bearing housing.
5. Insert the bearing:
The bearing races have two different inner diameters; the larger of the two must be placed over the shaft first, then the ball cage, followed by the smaller I.D. race on top.
Note: The bearing races must be installed properly or the hook may not swivel as freely.
6. Thread the castle nut (4) on the end of the shaft. Tighten the nut until it bottoms and just begins to lightly compress the felt washer (do not over tighten the nut and crush the felt). Back off the nut until the next notch lines up with the roll pin hole in the hook shaft. Check to see if the hook turns freely. If it does not, then back off the nut to the next notch. The felt should be lightly compressed.
7. Pass the roll pin (10) through the access hole and press it into the shaft. Center it in the nut.
8. Re-seal the roll pin access holes with RTV silicone.
9. Apply a medium/high strength locking compound to the swivel top (3) and screw into weldment (2) until tight.
10. Using a medium/high strength locking compound install set screws (6) into weldment.
11. Safety wire set screws (6) to the swivel top (3).
12. Install grease fitting (12) with a low/high strength locking compound.
13. Lubricate assembly using Mobilgrease 28 grease or equivalent using grease fitting (12). Be careful to not overfill.
14. Perform Acceptance Test Procedures as listed in Section 4 of this manual.

Acceptance Test Procedures

After the Crew-Loc Hook has been assembled or repaired it should be subjected to the Acceptance Test Procedure as follows.

1. Examine the Crew-Loc Hook externally for security of fasteners.
2. Suspend the Crew-Loc Hook from a test rig capable of loading the Crew-Loc Hook to 12,000 pounds. Use a nylon sling or a steel ring to apply the load to the load beam. Gradually load the Crew-Loc Hook on the test rig to 12,000 pounds. Hold the load for at least 30 seconds. The Crew-Loc Hook should hold the load securely. Reduce the load to zero and remove the rigging.
3. Submit the Crew-Loc Hook to a function test after removal of the proof load:
 - Verify the Snap Hook swivels freely.
 - Verify the Load Beam opens and closes smoothly.
 - Verify the Release Lever locks when the Load Beam is closed.

Crew-Loc Hook Exploded View

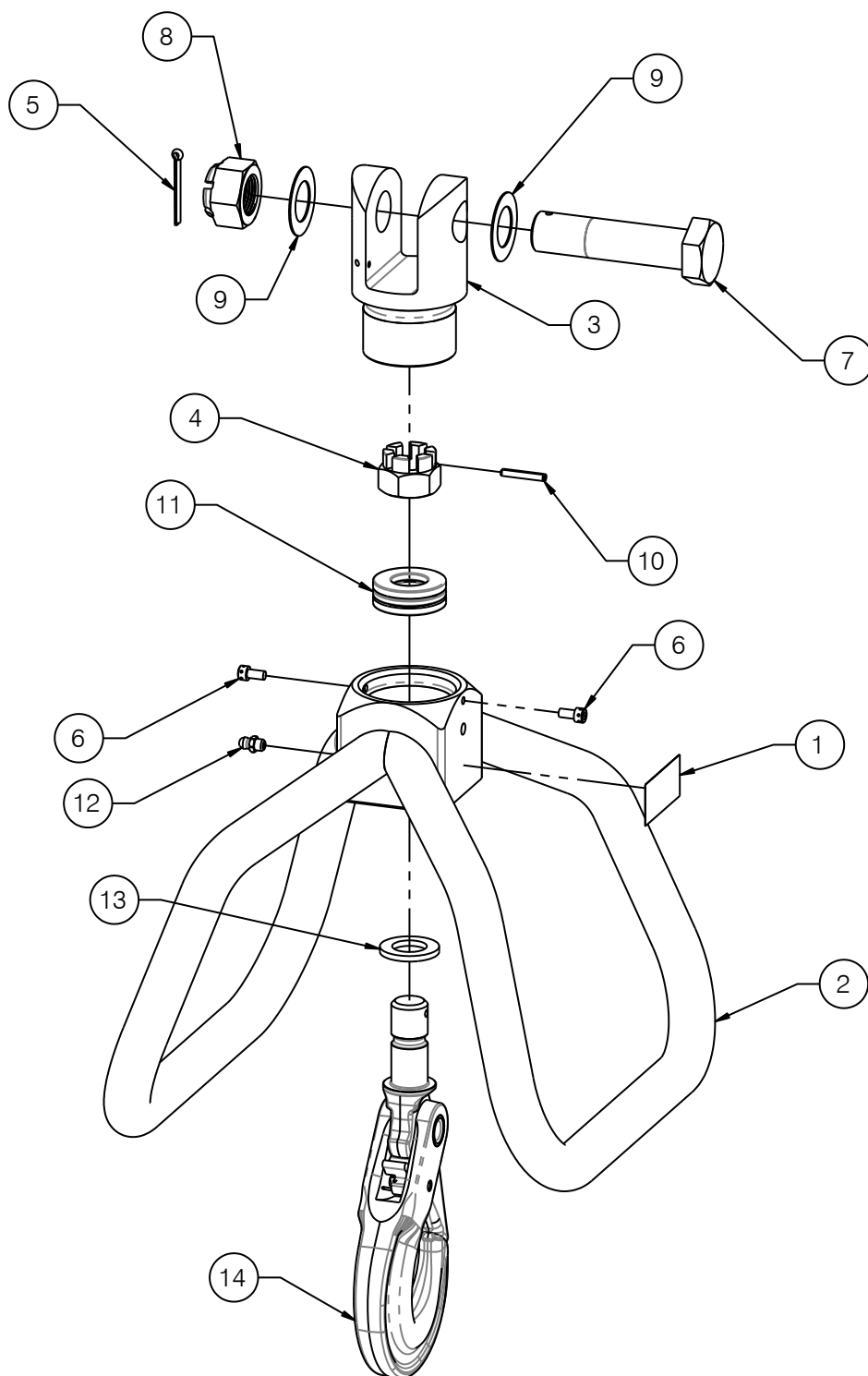

Figure 4-2 Crew-Loc Hook Parts

Crew-Loc Hook Parts

This section describes and lists the assemblies and detail parts of the Crew-Loc Hook.

Table 4-2 Crew-Loc Hook Parts

Item No.	Part Number	Description	Quantity
1	215-268-00	Serial Number Decal	1
2	235-275-00	Cage Weldment	1
3	291-477-00	Swivel Top	1
4	*	Castle Nut	1
5	510-098-00	Cotter Pin	1
6	510-156-00	Screw	2
7	510-887-00	Bolt	1
8	510-888-00	Nut	1
9	510-889-00	Washer	2
10	511-160-00	Roll Pin	1
11	517-118-00	Thrust Ball Bearing	1
12	518-004-00	Grease Fitting	1
13	521-015-00	Bearing Felt	1
14	530-026-00	Snap Hook Assembly	1

*Part of Snap Hook Assembly

Instructions for Returning Equipment to the Factory

If an Onboard Systems product must be returned to the factory for any reason (including returns, service, repairs, overhaul, etc.) obtain an RMA number before shipping your return.



An RMA number is required for all equipment returns.

- To obtain an RMA, please use one of the listed methods.
 - Contact Technical Support by phone or e-mail (Techhelp@OnboardSystems.com).
 - Generate an RMA number at our website:
<http://www.onboardsystems.com/rma.php>
- After you have obtained the RMA number, please be sure to:
 - Package the component carefully to ensure safe transit.
 - Write the RMA number on the outside of the box or on the mailing label.
 - Include the RMA number and reason for the return on your purchase or work order.
 - Include your name, address, phone and fax number and email (as applicable).
 - Return the components freight, cartage, insurance and customs prepaid to:

Onboard Systems
13915 NW 3rd Court
Vancouver, Washington 98685
USA
Phone: 360-546-3072