

OWNERS MANUAL
HYDRAULIC
HOOK LOAD MEASURING SYSTEM
FOR
BELL HELICOPTER 206 A & B SERIES
WITH 2A15 E HOOK
MODEL H-45

ONBOARD SYSTEMS
11212 NW SAINT HELENS RD.
PORTLAND, OR 97231
TELEPHONE (503) 286-4956
TELEX 362643 (ONBOARD PTL)
FAX (503) 286-0370

DOCUMENT NUMBER 120-015-00
DOCUMENT REVISION B
SYSTEM PART NUMBERS
200-022-00 SYSTEM WITH LB INDICATOR
200-023-00 SYSTEM WITH KG INDICATOR
OLD PART NUMBER WAS 2539
JANUARY 10, 1990

TABLE OF CONTENTS

SECTION 1	GENERAL INFORMATION
1.1	Introduction
1.2	Specifications
1.3	Inspection
SECTION 2	INSTALLATION INSTRUCTIONS
2.1	Introduction
2.2	Installation Overview
2.3	Load Cell Installation
2.4	Quick Disconnect Assembly Installation
2.5	Indicator Installation
2.6	Hard line Installation
2.7	Installation Check Out
2.8	Weight and Balance
2.9	Paper Work
SECTION 3	OPERATION INSTRUCTIONS
3.1	Introduction
SECTION 4	MAINTENANCE
4.1	Calibration
4.2	Refilling the Load Cell and Soft Line
4.3	Refilling the Hard Line
4.4	Silicone Oil Substitution
4.5	Indicator Maintenance
4.6	Load Cell Maintenance
4.7	Parts List
SECTION 5	TROUBLE SHOOTING
5.1	Introduction
5.2	Instructions For Returning a System to the Factory
SECTION 6	LIMITED WARRANTY
SECTION 7	STC # SH759NW
SECTION 8	FAA APPROVED FLIGHT MANUAL SUPPLEMENT

SECTION 1
GENERAL INFORMATION

1.1 INTRODUCTION

The Onboard Hook Load Measuring System is a compliment to the helicopter lifting system. Its purpose is to display the cargo hook load. A system consists of a load cell, a cockpit mounted indicator and miscellaneous attaching hardware and lines. The load cell is installed between the helicopter and the cargo hook. The indicator is scaled for readings in pounds (standard configuration) or kilograms. The system is designed specifically for each helicopter and is intended to be a permanent installation.

1.2 SPECIFICATIONS

System accuracy.....	1.0%
Indicator.....	270 Movement
Min. operating temp.....	-40C
Load cell overload capacity.....	4 times

1.3 INSPECTION

After receiving the system inspect each component for evidence of mishandling and damage. If damage is evident, do not use it. File a claim with the carrier and notify the distributor from whom the system was purchased.

SECTION 2

INSTALLATION INSTRUCTIONS

2.1 INTRODUCTION

The hook load measuring system is supplied with all fittings and lines to complete a FAA approved installation. All lines and fittings have been filled with oil and capped. Caution must be exercised before removing the caps to insure against contamination and loss of oil. All lines and fittings are connected whenever possible to speed installation. If separation is necessary for a modified installation, refer to the maintenance section under Refilling the Line.

When connecting two fittings, it is usually necessary to add a drop or two of oil to each fitting to fill the voids left by the caps. It is essential that a solid column (no air bubbles) of oil connect the load cell to the indicator.

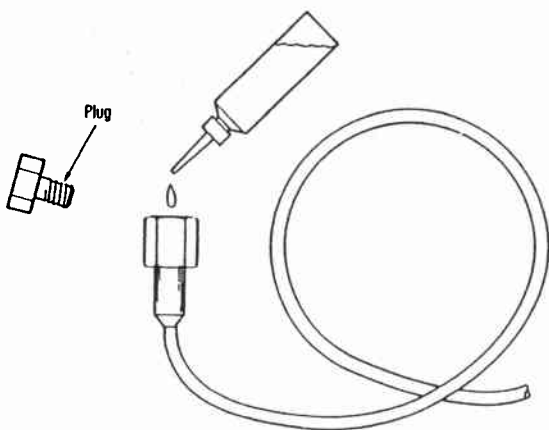

The load cell acts as a pressure transducer, it produces a pressure signal proportional to the applied load. Therefore, once the load cell is installed, the line between the load cell and the indicator must not be separated except at the quick disconnect unless the weight of the cargo hook is completely supported. Otherwise, the weight of the cargo hook on the load cell will force all of the oil from the load cell through the open line.

2.2 INSTALLATION OVERVIEW

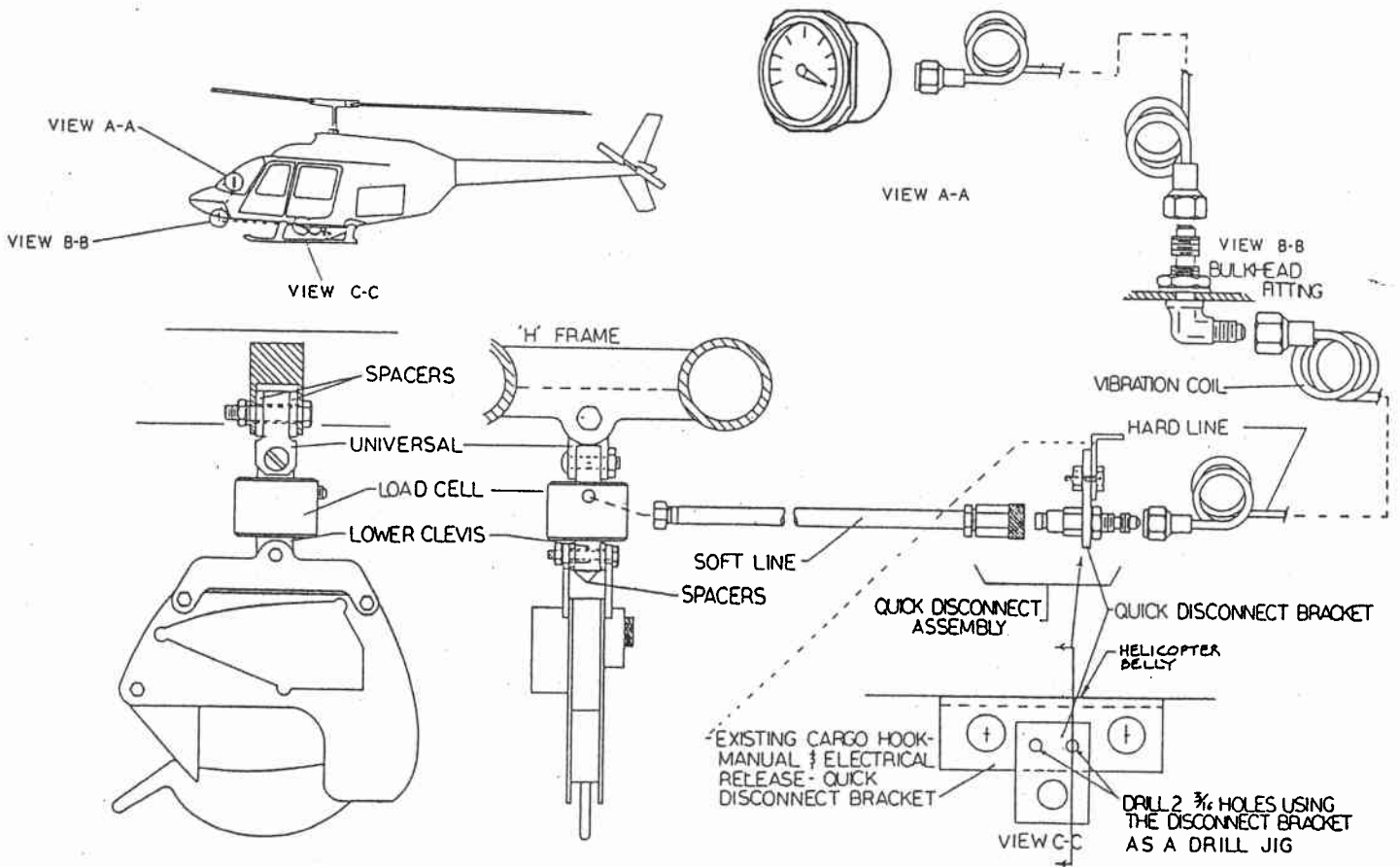

2.3 LOAD CELL INSTALLATION

Separate the cargo hook from the aircraft at the cargo hook. Remove the universal P/N 204-011-128-1, it will not be used.

Attach the load cell lower clevis to the cargo hook using the existing hardware. Attach the load cell upper clevis to the "H" Frame assembly using the existing hardware.

AFTER THE INSTALLATION SWING THE HOOK ASSEMBLY TO THE FULL EXTREMES TO VERIFY THAT ITS MOVEMENT IS NOT RESTRICTED BY THE SOFT LINE AND THAT IT WILL NOT SELF TRIP.

2.4 QUICK DISCONNECT ASSEMBLY INSTALLATION

Attach the quick release bracket to the cargo hook electrical release bracket as shown.

2.5 INDICATOR INSTALLATION

The indicator should be mounted in a position that is convenient, accessible, and visible to the pilot. It is designed to be mounted in a standard 3-1/8" instrument hole but can be mounted at any convenient location including outside the aircraft. If the indicator is to be mounted outside, a special weather resistant model should be ordered. The indicator dial in indicators after S/N 10895 can be rotated in relation to the bezel. To rotate the dial loosen the 4 bezel screws and rotate the dial to the desired position and retighten the screws.

2.6 HARD LINE INSTALLATION

Drill a 7/16" hole in the right corner of the left chin glass and install the bulkhead fitting as shown.

Attach the 5' hard line to the quick disconnect assembly and the bulkhead fitting. Attach the other hard line to the bulkhead fitting and the indicator. Connect the fittings using sufficient oil to fill the voids left by the plugs. Secure the line with ty-raps. Extra time spent securing the lines against vibration will insure years of trouble free use.

2.7 INSTALLATION CHECK OUT

Prior to initial use insure that the lines are securely tightened and secured away from flight control rods and hot hydraulic lines.

Insure that the cargo hook assembly is free to move in all possible directions and is not restrained by the Load Cell soft lines or the cargo hook release cables.

After a short use period check all of the fittings for sign of leaks, correct as necessary.

If excess oil is lost during assembly refer to the refilling the system section 4.2.

2.8 WEIGHT AND BALANCE

ITEM	WEIGHT (pounds)	STATION (inches)	MOMENT (inch pounds)
Indicator	1.0		
Load cell & lines	2.5		

2.9 PAPER WORK

In the USA fill in FAA form 337 for the initial installation. This procedure may vary in different countries.

Make the appropriate aircraft log book entry.

SECTION 3
OPERATION INSTRUCTIONS

3.1 INTRODUCTION

All operation procedures with the Hook Load Measuring System installed are the same as normal procedures.

SECTION 4 MAINTENANCE

4.1 CALIBRATION

The system has been calibrated with weights traceable to the National Bureau of Standards however, a calibration check should be performed on an annually or whenever the system readings are questionable.

The preferred method of calibration is to hang a known weight on the cargo hook. The known weight should be at least 50% of the aircraft lifting capacity.

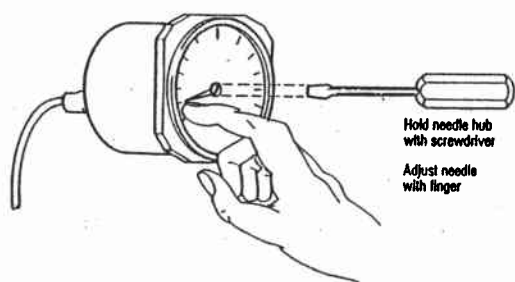

To adjust the indicator remove the bezel and insert a screwdriver into the slot at the center of the indicator needle. Hold the screwdriver stationary and move the needle carefully with your fingers to the known weight. Release the screwdriver and the needle should be indicating the know weight. Repeat the procedure until the needle is showing the exact weight.

NOTE: The calibration procedure should not be attempted without insuring the load cell and lines are properly filled with oil.

4.2 REFILLING THE LOAD CELL AND SOFT LINE

The load cell contains approximately 1 1/2 cubic inches of oil. If this oil is lost through incorrect installation or leakage the load cell piston will bottom against the cylinder resulting in an erroneous reading or no reading at all. A small drop of oil is lost each time the quick disconnect assemble is used. Normal maintenance is usually limited to an occasional refilling of the cell. The cell should be refilled using the same type of oil that was previously used. The factory uses SF97-100 silicone oil. Other oil can be used in moderate climates however two types of oil must never be mixed in the load cell. See section 4.6.

4.2 REFILLING THE LOAD CELL AND SOFT LINE (CONTINUED)

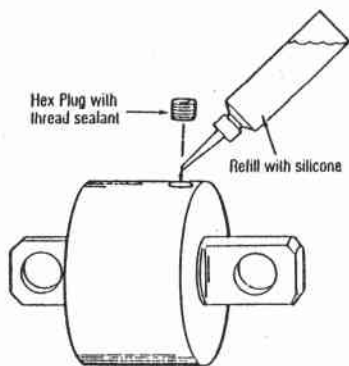

With a squeeze bottle slowly fill the oil chamber. Turn the load cell to let trapped air bubbles escape. Care should be taken not to agitate the oil as air bubbles will be entrapped. Allow sufficient time for air in the soft line to be worked up through the fill port (about 20 minutes at 60F). Fill the load cell to the top of the port. Reinstall the plug using a non contaminating thread sealant.

4.3 REFILLING THE HARD LINE

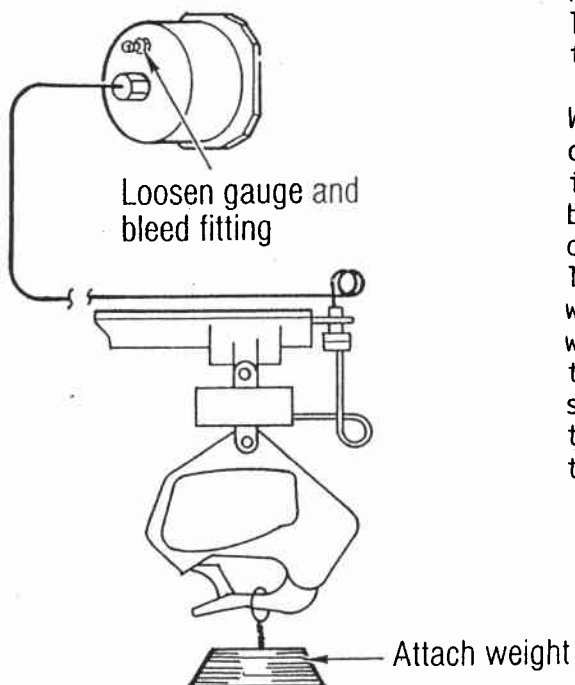

Fill the load cell and soft line before attempting to fill the hard line.

With the load cell system completely assembled and installed, loosen the indicator bleed valve located on the back of the indicator. Stretch the load cell, or apply a small weight to the load cell. This will force the air bubbles out the bleed valve. When the oil stream is clear of bubbles, tighten the valve and refill the load cell.

4.4 SILICONE OIL SUBSTITUTION

The use of SF 97-100 silicone oil allows the system to operate down to -40 degrees. If this low temperature operation is not necessary other oils can be substituted for the silicone oil. Only oils compatible with Buna N seals should be used. Type A automatic transmission oil or MIL-5606 are acceptable substitutes. When changing oils it is necessary to disassemble the load cell and thoroughly remove the silicone oil. A product with the consistency of bubble gum will be formed if the silicone is not cleaned from the load cell before another type of oil is added. The bubble gum will cause the load cell seals to leak. It is not necessary to remove the silicone oil from the hard lines or the indicator.

4.5 INDICATOR MAINTENANCE

The Indicator requires no maintenance, opening or attempting repairs will void the warranty.

4.6 LOAD CELL MAINTENANCE

DAILY INSPECTION

Inspect the load cell and adaptor clevis in the area of the bolt holes for evidence of cracks and corrosion. Replace if cracks are found and treat corrosion with zinc chromate. Inspect the attaching hardware for security for and excessive wear.

250 HOUR INSPECTION

Inspect the load cell and adaptor clevis holes and bolts for cracks, elongation and wear. Replace as necessary.

	REPLACE
1/2" Holes	0.505
5/8" holes	0.630

Check for evidence of corrosion, if found remove and treat with zinc chromate primer.

Reinstall the load cell using a general purpose grease (MIL-G-3278) on the bolts.

4.6 LOAD CELL MAINTENANCE (CONTINUED)

500 HOUR INSPECTION

Inspect the load cell to overhaul criteria.

OVERHAUL

Return the indicator, load cell and any adaptor clevis to the factory for overhaul.

This document when released outside Onboard Systems is supplied for identification, engineering evaluation, or inspection purposes only and shall not be duplicated, used or disclosed to produce articles and/or subject matter covered thereby without the written permission of Onboard Systems. By accepting this document, the recipient agrees to affix this legend to any duplication or reproduction, in whole or part of the document of information disclosed thereby made pursuant to such permission.

For a description of any revisions see document number 150-066-00

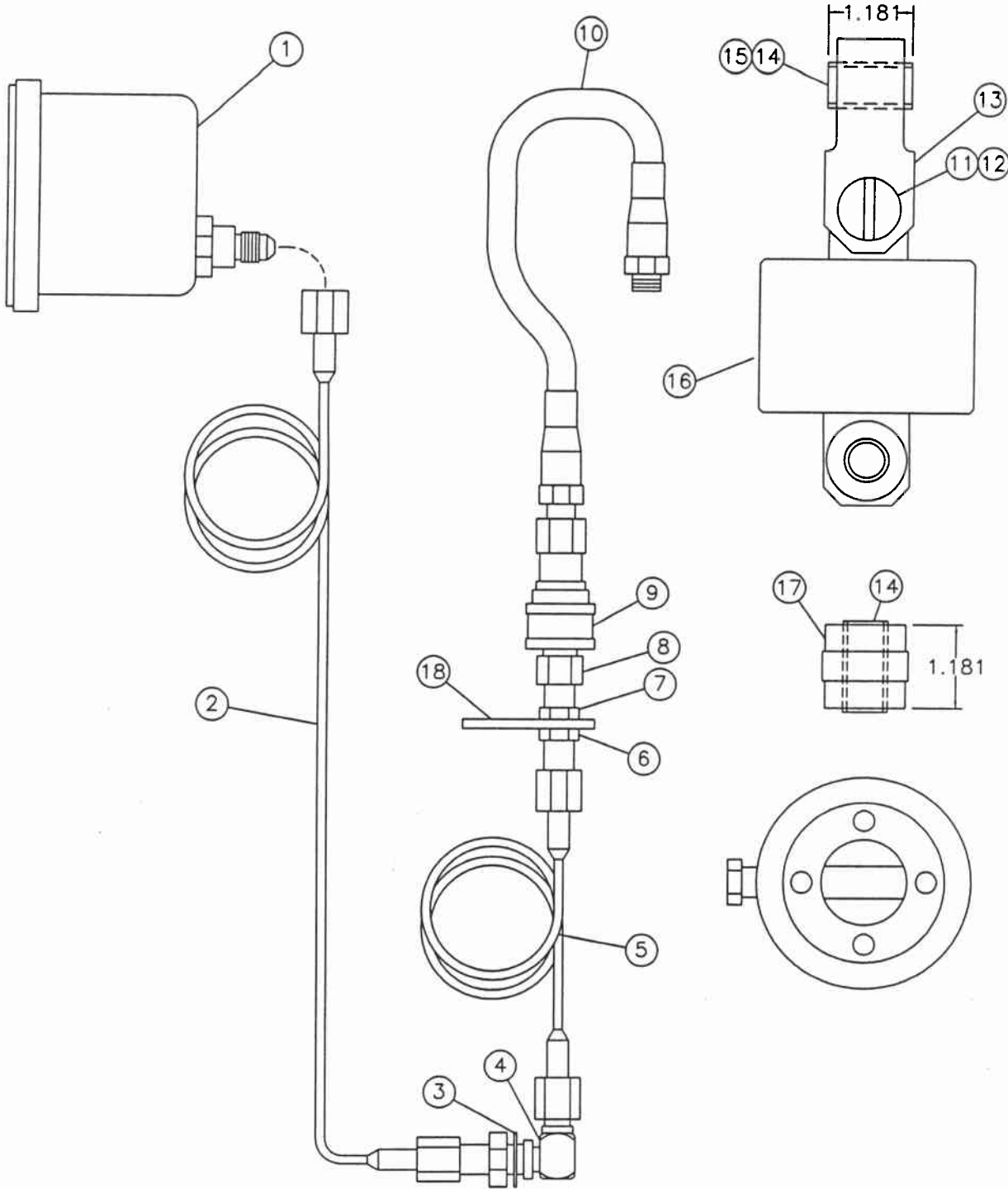

THE OLD SYSTEM P/N WAS 2539

UNLESS OTHERWISE SPECIFIED
DIMENSIONS ARE IN INCHES
TOLERANCES ARE

±.005 LINEAR	±0.5 DEG. ANGLES	+.005 -.001 HOLES
-----------------	---------------------	-------------------------



TITLE

H-45 BELL 206 A&B
SERIES HOOK LOAD
MEASURING SYSTEM

DRN 12/9/89 BIC

CHK 12/17/89 ML REF

REVISED 9/9/99 JH SCALE

200-022-00

SHEET 1 OF 2

REV 3

H-45 Bell 206 A&B Series

Bill of Materials

Document Number 200-022-00 Sheet 2 of 2

Revision 3 September 9, 1999

ITEM	P/N	MFG.	MFG. P/N	DESCRIPTION	200-022-00	200-023-00
1	210-022-06	Onboard	Same	Indicator, 2400 LB	1	-
1	210-022-01	Onboard	Same	Indicator, 1100 KG	-	1
2	267-013-00	Onboard	Same	Hard Line 3'	1	1
3	510-054-00	Any	AN 960-716	7/16 Washer	2	2
4	558-003-00	Adv. Hyd.	2701-04-04-LN	#4 Fitting	1	1
5	267-014-00	Onboard	Same	Hard Line 5'	1	1
6	510-039-00	Any	AN 924-4	Nut	1	1
7	290-015-00	Onboard	Same	Bulkhead Fitting	1	1
8	560-001-00	Hanson	1-K11	Disconnect	1	1
9	560-002-00	Hanson	1-H11	Disconnect	1	1
10	267-015-00	Onboard	Same	Soft Line 22"	1	1
11	510-038-00	Any	AN 8-21	Clevis Bolt	1	1
12	510-036-00	Any	AN 320-8	Clevis Nut	1	1
13	290-021-00	Onboard	Same	Clevis	1	1
14**	290-046-00	Onboard	Same	Bushing	2	2
15	290-047-00	Onboard	Same	Spacer	2	2
16	210-156-00	Onboard	Same	Load Cell Assembly	1	1
17**	290-048-00	Onboard	Same	Spacer	2	2
18	235-021-00	Onboard	Same	QD Bracket	1	1
19*	120-015-00	Onboard	Same	Owners Manual	1	1

* Item not illustrated

** Item 14 & 17 are included with Item 16, P/N 210-156-00 Load Cell Assembly.

SECTION 5
TROUBLE SHOOTING

5.1 INTRODUCTION

PROBLEM

SOLUTIONS

The indicator reads significantly less than the actual load.

The problem is usually caused by a lack of oil in the load cell. Refer to refilling the system section 4.2 & 4.3. Check for leaks and correct. If the problem persists, follow the calibration procedures section 4.1.

The indicator shows a load reading when the load cell is REMOVED from the aircraft.

The load cell contains the system temperature compensation feature. When the load cell is removed from the aircraft a temperature increase will cause the oil in the Indicator and lines to expand. This expansion will result in a indicator load reading. If this reading exceeds the indicator full scale reading permanent damage will result. To prevent this problem relieve the system pressure by coupling and uncoupling the quick release fitting several times. This will cause several drops of oil to be lost from the lines allowing room for oil expansion.

The indicator shows a load when the load cell is installed but no load is applied.

This is caused by over filling the load cell (eliminating the temperature compensation space). Remove 4-5 drops of oil from the system by coupling and uncoupling the quick release fitting several times.

5.2 INSTRUCTIONS FOR RETURNING A SYSTEM TO THE FACTORY

If a system, or part, must be returned to the factory please follow these directions.

1. Write as detailed an explanation as possible explaining the problem, when it occurred and whether it is an intermittent problem or a permanent problem.
2. Package the unit carefully to insure safe transit.
3. Include your name, address, and phone, fax or telex number.
4. Return the unit to:

ONBOARD SYSTEMS
11212 NW SAINT HELENS RD.
PORTLAND, OR. 97231
USA

SECTION 6

LIMITED WARRANTY

6.1 INTRODUCTION

ONBOARD SYSTEMS warrants for a period of one year from the purchase date that the Hook Load Measuring System will be free from defects in workmanship and material when properly installed and subjected to reasonable care for its intended purpose.

Parts which prove to be defective will be repaired or replaced free of charge FOB factory, provided:

1. No repairs have been attempted by other than Onboard Systems personnel.
2. The system or part has been returned properly packaged, insured with transportation charges prepaid.
3. Upon Examination, Onboard Systems personnel are satisfied that the defects were not caused by abuse or subjected to conditions that violate the system specifications.

No other warranties are expressed or implied, Onboard Systems, is not liable for consequential damages. The user must satisfy himself that the System is suited to his needs and is performing according to his requirements. This warranty covers the original purchaser only.

United States of America
Department of Transportation — Federal Aviation Administration
Supplemental Type Certificate

Number SH759NW

This certificate, issued to Onboard Systems

certifies that the change in the type design for the following product with the limitations and conditions therefor as specified hereon meets the airworthiness requirements of Part 6 of the Civil Air Regulations.

Original Product — Type Certificate Number: H2SW
Make: Bell
Model: 206A and 206B

Description of Type Design Change: Installation of Model 2539 weighing system in accordance with Onboard Weighing Systems Installation Instructions Drawing Number 2534; or Fabrication of Onboard Systems Model H-45 Cargo Hook Load Cell System in accordance with FAA approved Onboard System Master Drawing List No. 155-011-00, dated January 10, 1990, or later FAA approved revision; and, Installation of this system in accordance with FAA approved Onboard Systems Owners Manual No. 120-015-00, Revision "B", dated January 10, 1990, (See Continuation Sheet)

Limitations and Conditions: Approval of this change in type design applies to the above model helicopters only. This approval should not be extended to other helicopters of these models on which other previously approved modifications are incorporated unless it is determined by the installer that the relationship between this change and any of those other previously approved modifications, including changes in type design, will introduce no adverse effect upon the airworthiness of that helicopter. (See Continuation Sheet)

This certificate and the supporting data which is the basis for approval shall remain in effect until surrendered, suspended, revoked, or a termination date is otherwise established by the Administrator of the Federal Aviation Administration.

Date of application: April 5, 1979

Date issued: August 8, 1990

Date of issuance: May 3, 1979

Date amended: August 8, 1990



By direction of the Administrator

Stewart K. Miller
(Signature)

Assistant Manager, Seattle
Aircraft Certification Office

(Title)

Any alteration of this certificate is punishable by a fine of not exceeding \$1,000, or imprisonment not exceeding 3 years, or both.

This certificate may be transferred in accordance with FAR 21.47.

United States of America
Department of Transportation—Federal Aviation Administration
Supplemental Type Certificate
(Continuation Sheet)

Number SH759NW

DESCRIPTION OF TYPE DESIGN CHANGE: (continued)

or later FAA approved revision. Inspect load cell in accordance with Section 4.6 of Onboard Systems Owners Manual No. 120-015-Q0, Revision "B", dated January 10, 1990, or later FAA approved revision.

LIMITATION AND CONDITIONS: (continued)

Rotorcraft modified in accordance with this STC must be operated in accordance with an FAA approved copy of the Rotorcraft Flight Manual Supplement revised August 8, 1990, or later FAA approved revision. A copy of this Certificate, Continuation Sheet No. SH759NW, the maintenance manual and FAA approved Rotorcraft Flight Manual Supplement must be maintained as part of the permanent records of the modified helicopter.

~~Any alteration of this certificate is punishable by a fine of not exceeding \$1,000, or imprisonment not exceeding 3 years, or both.~~

Onboard Systems
11212 NW. St. Helens Rd.
Portland, OR 97231
STC No. SH759NW

FAA APPROVED
ROTORCRAFT FLIGHT MANUAL SUPPLEMENT
FOR
BELL MODEL 206A AND 206B HELICOPTERS
R/N _____ S/N _____

This supplement must be attached to the appropriate FAA approved Bell Rotorcraft Flight Manual when an Onboard Systems Model H-45 Cargo Hook load cell is installed in accordance with Supplemental Type Certificate (STC) NO. SH759NW. The information contained herein supplements or supersedes the basic manual only in those areas listed herein. For limitations, procedures, and performance information not contained in this supplement, consult the basic Rotorcraft Flight Manual.

I. LIMITATIONS

No change.

II. PROCEDURES

After installation of this system, swing hook assembly to full extremes to verify that it does not self trip.

III. PERFORMANCE

The hook load weighing system is designed and installed as a means of MONITORING the load (weight) suspended from the cargo hook. Functional and performance characteristics have not been determined on the basis of the load cell indication or display. Therefore, this instrument shall NOT be used as a primary indication of performance and flight operation must NOT be predicated on its use.

FAA Approved: Stewart R. Muller
Assistant Manager, Seattle
Aircraft Certification Office

Date: May 3, 1979
Revised: August 8, 1990



Transport
Canada

Aviation

Transports
Canada

Aviation

Aircraft Certification Branch
620 - 800 Burrard Street
Vancouver, BC V6Z 2J8

Your file Votre référence
99-190S-423
Our file Notre référence

September 17, 1999

Onboard Systems
11212 NW Saint Helens Road
Portland, OR 97231
USA

Attention: Mr. Mark Lemmon

Subject: **Familiarization of FAA STCs SH1038NW and SH759NW on Bell 206 Series Rotorcraft**

Dear Mr. Lemmon:

This is in response to your application requesting the familiarization of the subject FAA STCs. Consistent with Transport Canada revised policy regarding STC familiarization requirements intended for the Bell 206 rotorcraft, these subject STCs may be accepted under the terms of the Canada/US Bilateral Airworthiness Agreement and no longer require an airworthiness review.

The revised Transport Canada policy regarding STCs installed on Bell 206 rotorcraft is as follows:

- a) An STC issued by the FAA prior to the 14 September 1995, and for which its first installation on a Canadian registered Bell 206 rotorcraft is accomplished later than 14 September 1995 is considered "grandfathered", thus does not require an airworthiness review.
- b) An STC issued by the FAA on the 15 September 1995 or later, and subsequently installed on a Canadian registered Bell 206 rotorcraft requires a Level 2 review, including the issue of a corresponding STC."

In closing , the FAA STCs SH1038NW and SH759NW being issued prior to the 14 September 1995 do not require an airworthiness review and are accepted in Canada.