	Component Maintenance Manual	Document Number 122-017-00	Revision 32
		Date 01/03/23	Page 1 of 36

# Component Maintenance Manual, Cargo Hook


**Onboard Systems International**  
13915 NW 3rd Court  
Vancouver, WA 98685 United States of America  
Cage Code: 1Y921

Toll Free Phone: (800) 275-0883  
Phone: (360) 546-3072  
Fax: (360) 546-3073

## Applicable Equipment Part Numbers

528-027-01  
528-029-00  
528-029-01  
528-029-02  
528-029-04  
528-029-60

***Please check our web site [www.onboardsystems.com](http://www.onboardsystems.com)  
for the latest revision of this manual.***

	<b>Component Maintenance Manual</b>	Document Number 122-017-00	Revision 32
		Date 01/03/23	Page 2 of 36


### RECORD OF REVISIONS

Revision	Date	Page(s)/ Section(s)	Reason for Revision
18	08/06/13	5, 6, 8, 22	Changed solenoid in 528-029-01 to 455-007-00. Added requirement to maintain record of all cargo hook activity (pg 5). Added Storage and Inactivity section. Added Section 6.3.
19	12/10/13	16-17	Added toggle pin installation warning.
20	03/03/14	12 & 14-26	Added Cam Bearing deburr warning and Figure 9.2.
21	03/24/15	9-10 & 16-25	Updated disassembly & assembly instructions and added photos. Added 215-253-10 and 215-254-10 to Table 13.1 notes.
22	01/26/16	4, 10, 11, 13, 23, 24, 25 - 33	Added cargo hook P/N 528-029-02 (includes Surefire Release) and associated instructions and parts. Removed Cam from NDT list.
23	11/30/17	10, 13, 28	Clarified disassembly instructions (sections 8.10 thru 8.13) and P/N applicability of Surefire functionality and parts.
24	01/19/18	10, 12	Removed NDT requirement for Solenoid Cam (7.2), Manual Release Lever (6.1) and Cam Roller Pin (13). Added inspection criteria for Solenoid Cam and Release Lever to Table 9.1.
25	02/01/18	30, 32, 33	Added Connector Cap (item 7.15, applicable to cargo hook P/N 528-027-01 only) to Figure 13.1 and Table 13.1
26	01/14/20	6, 11	Replaced NDT inspection of Toggle (4.2) and Load Beam Assembly (2.2, 2.1) with magnified visual inspection; moved inspection step to Table 9.1. Changed item 1 of section 4.5 to require a functional check rather than full ATP.
27	06/08/22	All	Added 528-029-04 and associated instructions. Added 212-072-00 overhaul kit. Added load beam axial migration inspection step to Table 9.1. Added -04 specific load beam damage criteria.
28	07/15/22	5, 8	Added grace period to maintenance and overhaul schedule. Specified that calendar time is sufficient for -04 hook interval. Added sections references for overhaul and maintenance.
29	07/19/22	4.3, 6.1	Maintenance grace period wording standardized.
30	07/25/22	4.3, 10.26	Specified to inspect exterior for cracks, specified table 9.1 for inspection criteria. Added install instructions for manual release guard.
31	10/19/22	4.3, 4.4	Remove requirement to remove -04 hook from aircraft from annual inspection. Remove requirement to lubricate attach hardware from annual inspection. Add biennial inspection for -04 hook only.
32	01/03/23	12, 15, 16, 19, 33	Add cleaning and inspection instructions for cam surfaces. Add cam assembly to overhaul kits.

#### Register Your Products for Automatic Notifications

Onboard Systems offers a free notification service via fax or email for product alerts and documentation updates. By registering your Onboard Systems products at our website, we will be able to contact you if a service bulletin is issued, or if the documentation is updated.

You can choose to receive notices on an immediate, weekly, or monthly schedule via fax, email or both methods. There is no charge for this service. Please visit our website at [www.onboardsystems.com/notify.php](http://www.onboardsystems.com/notify.php) to get started.

	<b>Component Maintenance Manual</b>	Document Number 122-017-00	Revision 32
		Date 01/03/23	Page 3 of 36

## 1.0 Introduction

- 1.1 **Scope.** This component maintenance manual contains instructions for inspection, maintenance and overhaul.
- 1.2 **Capability.** The instructions contained in this document are provided for the benefit of experienced aircraft maintenance personnel and facilities that are capable of carrying out the procedures.
- 1.3 **Safety Labels.** The following definitions apply to safety labels used in this manual.



Indicates a hazardous situation which, if not avoided, will result in death or serious injury.



Indicates a hazardous situation which, if not avoided, could result in death or serious injury.




Indicates a hazardous situation which, if not avoided, could result in minor or moderate injury.



Draws the reader's attention to important or unusual information not directly related to safety.



Used to address practices not related to personal injury.

	<b>Component Maintenance Manual</b>	Document Number 122-017-00	Revision 32
		Date 01/03/23	Page 4 of 36


## 2.0 Referenced Documents

- 180-172-00      Acceptance Test Procedure – Cargo Hook P/N 528-027-01, 528-029-00, 528-029-02, 528-029-04, 528-029-60
- 180-180-00      Acceptance Test Procedure – Cargo Hook P/N 528-029-01

## 3.0 Service Bulletins/Amendments

- 3.1      This component is subject to the following service bulletins. Service bulletin documents may be obtained from the Onboard Systems website. Verify compliance with all service bulletins prior to maintenance.

Service Bulletin	Description	P/N Applicability	S/N Applicability
159-026-00	Replace Manual Release Cover P/N 290-898-00 with P/N 290-898-01	528-029-00 528-029-01	All

	<b>Component Maintenance Manual</b>	Document Number 122-017-00	Revision 32
		Date 01/03/23	Page 5 of 36

## 4.0 Maintenance

- 4.1 Maintain a record of **ALL** cargo hook activities including aircraft installation and removal, inspections, repair and overhaul as well as inactivity and storage events.



*Failure to follow all equipment maintenance instructions and component inspection criteria may result in serious injury, death or immediate loss of flight safety.*

### 4.2 Cleaning and Preventative Maintenance

1. As needed per visual condition, remove accumulated soils from exterior with a soft bristle brush and mild solvent/cleaner.
2. As needed per visual condition, in salt water environments, apply a corrosion preventative compound such as ACF-50 to all exterior surfaces.

### 4.3 Annual Inspection


1. Annually\*, or 100 hours of external load operations, whichever comes first, remove the Cargo Hook from the aircraft\*. Thoroughly clean the exterior with a soft bristle brush and mild solvent/cleaner and visually inspect exterior for cracks, gouges, dents, nicks, corrosion, and missing or loose fasteners. See Table 9.1 for inspection criteria. A one-month or 10-hour grace period can be applied if needed. No additional extension is allowed beyond this grace period.
2. Lubricate the Cargo Hook Attach Bolt or the Pin Load Cell\*. Recommended lubricants are Mobilgrease 28 or AeroShell 7 grease.

\*Cargo Hook P/N 528-029-04:

- Calendar time alone can be used to determine maintenance inspection intervals.
- Hook does not need to be removed from the aircraft for annual inspection.
- Attach hardware does not need to be lubricated at annual inspection.

### 4.4 Biennial Inspection (528-029-04 Only)

1. Biennially (every 24 months), or 200 hours of external load operations, whichever comes first, remove the Cargo Hook from the aircraft. Thoroughly clean the exterior with a soft bristle brush and mild solvent/cleaner and visually inspect exterior for cracks, gouges, dents, nicks, corrosion, and missing or loose fasteners. See Table 9.1 for inspection criteria. A two-month or 20-hour grace period can be applied if needed. No additional extension is allowed beyond this grace period. Calendar time alone can be used to determine maintenance inspection intervals.
2. Lubricate the Cargo Hook Attach Bolt. Recommended lubricants are Mobilgrease 28 or AeroShell 7 grease.

	<b>Component Maintenance Manual</b>	Document Number 122-017-00	Revision 32
		Date 01/03/23	Page 6 of 36

#### 4.5 **Overhaul**


1. Overhaul the Cargo Hook in accordance with the overhaul schedule and instructions contained in sections 7 and 9.

#### 4.6 **Storage and Inactivity**

1. The Cargo Hook may be stored in its original factory sealed bag and box for up to 2 years from its date of manufacture or last factory overhaul. If stored in its original factory sealed bag and box for less than 2 years, it may be used without any additional activity. If the period of storage in its original packaging is greater than 2 years, the Cargo Hook must be subjected to a functional check before being used. Perform the functional check per the instructions in section 10.7 through 10.9 of the acceptance test procedures (ATP) herein.
2. If the Cargo Hook has been installed on an aircraft and subsequently removed from service, store it in a reasonably protected indoor, dry, heated storage area for up to 6 months. If stored in this condition for less than 6 months, it may be used without any additional activity. If it is to be stored longer than 6 months, perform the following activities. Prepare the Cargo Hook for storage by thoroughly cleaning and drying the exterior, liberally applying ACF-50 corrosion preventative compound inside and out, sealing it in a plastic bag with a desiccant, and labeling it with the date of storage. If stored in this condition for less than 2 years, it may be placed in service without any additional activity. If the period of storage exceeds 2 years the Cargo Hook must be subjected to the ATP described herein before being placed in service.
3. If the Cargo Hook has been installed on the aircraft and subsequently removed from service but not stored in accordance with the instructions above, the Cargo Hook must be subject to the ATP described herein before being placed in service.


#### 4.7 **Repair**

1. Repair the Cargo Hook in accordance with the repair instructions contained here-in.

	<b>Component Maintenance Manual</b>	Document Number 122-017-00	Revision 32
		Date 01/03/23	Page 7 of 36

## 5.0 Repair Instructions

- 5.1 It is recommended that only minor repairs be attempted by anyone other than the factory. The following procedures and information are provided for the benefit of experienced aircraft maintenance facilities capable of carrying out the procedures. They must not be attempted by those lacking the necessary expertise and suitable equipment to perform the acceptance test procedures on the Cargo Hook after maintenance. See Section 14 for instructions for returning equipment to the factory.
- 5.2 Reference numbers throughout this manual shown in parentheses ( ) refer to Table and Figure 13.1.
- 5.3 Follow these steps to repair the Cargo Hook, referring to the applicable sections in this manual:
1. Disassemble as required.
  2. Inspect disassembled parts.
  3. Obtain required replacement parts.
  4. Reassemble.
  5. Acceptance test.
  6. Inspect for return to service.

	<b>Component Maintenance Manual</b>	Document Number 122-017-00	Revision 32
		Date 01/03/23	Page 8 of 36

## 6.0 Overhaul Schedule

- 6.1 The Cargo Hook shall be overhauled every 1000 hours of external load operations or 5 years\*, whichever comes first. A six-month or 100-hour grace period can be applied if needed. No additional extension is allowed beyond this grace period.
- 6.2 Hours of external load operations should be interpreted to be (1) anything is attached to the primary cargo hook (whether or not a useful load is being transported) and (2) the aircraft is flying. If these conditions are not met, time does not need to be tracked. If a C-40 Load Weigh Indicator is used in conjunction with the Cargo Hook, it can be used to track external load hours.
- 6.3 The 5-year period is from the initial installation date when the Cargo Hook is new or newly overhauled, regardless of storage or inactivity periods. If initial installation date is unknown, then 5-year period is from date of manufacture as indicated on the Cargo Hook data plate or 5 years from date of last overhaul indicated on the overhaul sticker.

\*Cargo Hook P/N 528-029-04: Calendar time alone can be used to determine maintenance, inspection and overhaul intervals.

## 7.0 Overhaul Instructions

- 7.1 It is recommended that only minor repairs be attempted by anyone other than the factory. The following procedures and information are provided for the benefit of experienced aircraft maintenance facilities capable of carrying out the procedures. They must not be attempted by those lacking the necessary expertise and suitable equipment to acceptance test the Cargo Hook after maintenance. See Section 14 for instructions for returning equipment to the factory.
- 7.2 Overhaul kit P/N 212-024-00\* is recommended to complete the Cargo Hook overhaul. The overhaul kit contains all recommended items to be replaced at time of overhaul. Table 13.1 lists detail parts contained in the overhaul kit.
- \*For 528-029-04 use kit P/N 212-072-00
- 7.3 Follow these steps to overhaul the Cargo Hook, referring to the applicable sections in this manual:
1. Obtain appropriate overhaul kit.
  2. Completely disassemble.
  3. Discard all items that are to be replaced by an item in the overhaul kit as listed in table 13.1.
  4. Inspect disassembled parts.
  5. Obtain any required replacement parts.
  6. Reassemble.
  7. Acceptance test.
  8. Inspect for return to service.

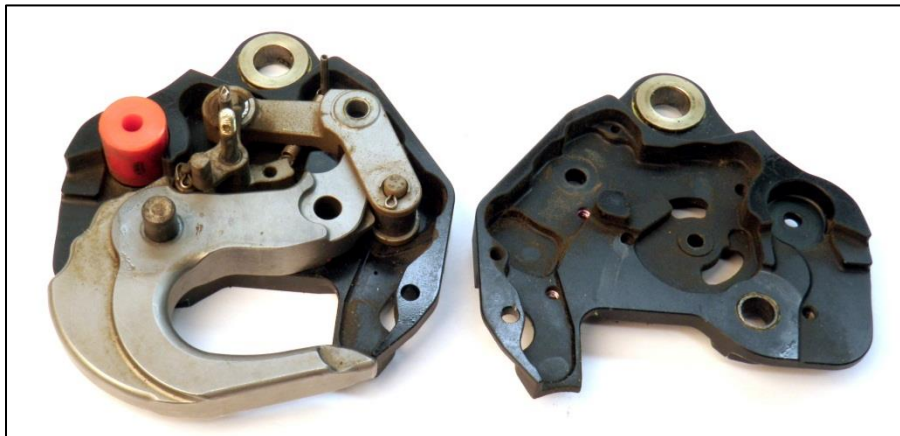


## 8.0 Disassembly Instructions

- 8.1 Remove manual release cover (14) by removing two screws (27).
- 8.2 For P/Ns 528-027-01 and 528-029-04 only - remove manual release guard cover (9) by removing screw (31), nut (17) and spring (34).
- 8.3 Remove cotter pin (21), nuts (24 and 20) and washers (19 and 23).
- 8.4 Remove bolts (16) and (25) and for P/Ns 528-027-01 and 528-029-04 only – remove guard base (10).




- 8.5 Remove Solenoid Assembly (7).
- 8.6 Remove nut (20) and bolt (26) and armor plates (11 and 12).
- 8.7 Remove cotter pin (22), nut (18) and washer (28) securing manual release lever.
- 8.8 Remove Manual Release Lever Assembly (6) and springs (33).
- 8.9 The Cargo Hook frame halves can now be separated by removing the Side Plate Assembly (5) from the remaining assembly. The internal mechanism can now be viewed and cycled to check for smooth operation. All of the internal parts may be removed at this time.



- 8.10 Note the orientation of the solenoid cam (7.2) and remove it by cutting the safety wire and removing three screws (7.9).



- 8.11 The solenoid (7.6) may be removed from the cover by removing two nuts (7.7), two washers (7.8) if applicable, and unsoldering its wires from the connector contacts. If the Surefire Module (applicable to cargo hook P/N 528-029-02 only) is installed, unsolder the wires from its terminals and remove the RTV silicone securing the wires to the cover. For 528-029-04 only, remove the connector contacts using the appropriate contact removal tools prior to unsoldering the pins.
- 8.12 The Surefire Module (7.10, P/N 528-029-02 only) may be removed by unsoldering the remaining two wires from its terminals, and removing the nut (7.12) from screw (7.11). The module is assembled with RTV silicone between it and the solenoid cover so light prying will be necessary to remove it.
- 8.13 The connector (7.5) may be removed by removing its nut on the outside of the cover. Note the connector orientation before removing.
- 8.14 Remove the attach bushings (5.1 and 8.1) by pressing them out of the side plates.
- 8.15 Other bushings and bearings may be removed from detail parts by conventional means.
- 8.16 The load beam shaft (2.1) typically does not need to be disassembled from the load beam (2.2).

	<b>Component Maintenance Manual</b>	Document Number 122-017-00	Revision 32
		Date 01/03/23	Page 11 of 36

## 9.0 Inspection Instructions

- 9.1 Thoroughly clean all parts to be inspected using standard methods. Parts should be completely free of surface contaminants, soils or grease before beginning inspections.
- 9.2 If the Cargo Hook is being overhauled, firstly perform nondestructive inspection on the following parts to confirm absence of surface cracks which may have developed in service. Confirmed cracks of any size are cause for part replacement.

For the **Side Plate, Solenoid (8.2)** and **Side Plate, Manual Release (5.2)**, inspect using:

- Liquid penetrant inspection per ASTM E1417

Mark all indications and then interpret each under 10X magnification. Differentiate surface cracks from other non-relevant indications such as machine tool marks, scratches, dents or superficial corrosion.

- 9.3 Carefully inspect detail parts in accordance with the instructions in Table 9.1. Inspect the parts in a clean, well-lighted room using standard dimensional measuring tools and visual methods. Repair parts found within inspection limits. Replace any part found beyond limits.

**Table 9.1, Cargo Hook Inspection Criteria**

Seq	Component	Inspection Criteria & Limit	Repair Action	Finish	Recommended replacement at overhaul.
1.	Load Beam Assembly (2), Toggle (4.2)	Surface cracks – inspect under illuminated magnification (minimum 2X / 4 diopter).	None. Cracks of any size are cause for part replacement.	N/A	No
2.	Load Beam Assembly (2) Manual Release Lever (6.1) Solenoid Cam (7.2) Armor Plate (11, 12)	Corrosion – 0.006 in. (0.127 mm) deep	Glass bead blast at less than 30 PSI (2.11 KGF/CM <sup>2</sup> ) to remove corrosion.	Passivate per AMS-QQ-P-35 or ASTM A967	No
3.	Load Beam Assembly (2)	Load Beam Shaft has moved axially within with the Load Beam - .393 in. ± .015 (ref. Figure 9.3	Press out Load Beam Shaft, clean mating surfaces, and press in with Loctite 680 retaining compound to depth shown in Figure 9.3.	N/A	No
4.	Side Plate (5.2, 8.2)	See Figure 9.1	Blend at 10:1 ratio as required to provide smooth transitions.	Apply alodine (MIL-DTL-5541) and zinc chromate primer (MIL-PRF-23377 or similar) to affected surfaces – see Note 1	No



# Component Maintenance Manual

Document Number  
122-017-00

Revision  
32

Date  
01/03/23

Page  
12 of 36

Seq	Component	Inspection Criteria & Limit	Repair Action	Finish	Recommended replacement at overhaul.
5.	Side Plate (5.2, 8.2)	Wear or deformation of top attach bushing hole ID – 0.6264 in (15.91 mm)	None	N/A	No
6.	Manual Rel. Cover (14) Solenoid Cover (7.3)	Dents, nicks, cracks, gouges, scratches and corrosion – 0.020 in. (0.50 mm) deep	Blend at 10:1 ratio as required to provide smooth transitions.	Apply alodine (MIL-DTL-5541) & zinc chromate primer (MIL-PRF-23377 or similar) to affected surfaces – see Note 1.	No
7.	Bearing (3.6, 3.7, 4.5, 5.5, 6.2, 8.4)	Wear – more than 50% copper showing	None	N/A	Yes
8.	Bearing (4.6)	Roughness, binding, looseness, or corrosion	None	N/A	Yes
9.	Attach Bushing (5.1, 8.1)	Wear on ID – 0.520 in (13.208 mm)	None	N/A	Yes
10.	Bumper (32)	Denting, cuts or abrasions – 0.060 in. (1.27 mm) deep	None	N/A	Yes
11.	Armor Plate (11, 12)	Gouges and nicks – 0.050 in. (1.27 mm) deep	Blend at 10:1 ratio as required to provide smooth transitions.	Passivate per AMS-QQ-P-35 or ASTM A967	No
12.	Cam Assembly (3)	See figure 9.2	None	N/A	Yes
13.	Cam assembly (3)	Roughness, binding or looseness of the Interlock Roller 3.1)	Replace Interlock Pin (3.4), Roller (3.1), and Bearings (3.7)	N/A	Yes
14.	Toggle Assembly (4)	Roughness, binding or looseness of the Load Beam Roller (4.1)	Replace Pin (4.4), Roller (4.1), and Bearings (4.5)	N/A	No
15.	Cam roller pin (13)	Visible denting, corrosion	None	N/A	No
16.	Manual Release Lever (6.1)	Deformation or damage at fork fitting	None	N/A	No
17.	Solenoid Cam (7.2)	Any measurable wear to cam surfaces	None	N/A	No
18.	Load Beam (2.2)	Wear, gouges and nicks – 0.050 in. (1.27 mm) deep  For -04 Cargo Hook See figure 9.4	Blend at 10:1 ratio as required to provide smooth transitions and ensure load rings will not hang up during release.	Passivate per AMS-QQ-P-35 or ASTM A967	No
19.	Serial Number Plate (7.1)	Damaged or illegible	None	N/A	No



# Component Maintenance Manual

Document Number  
122-017-00

Revision  
32

Date  
01/03/23

Page  
13 of 36

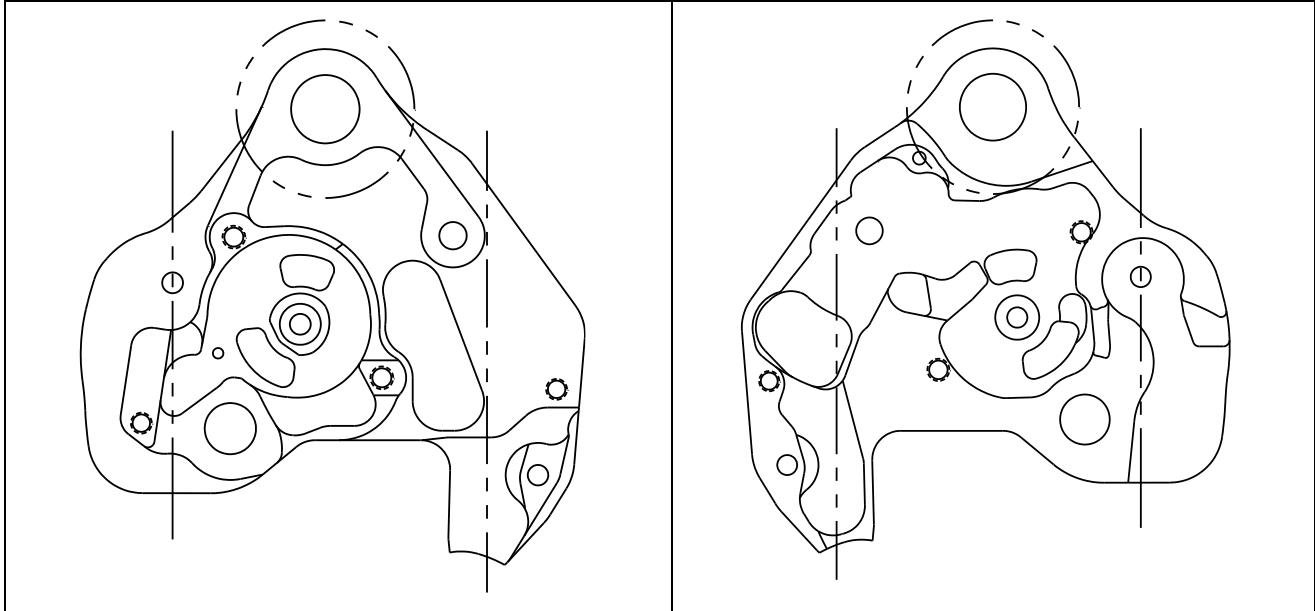
Seq	Component	Inspection Criteria & Limit	Repair Action	Finish	Recommended replacement at overhaul.
20.	Solenoid (7.6)	Shorted or open electrical circuit. For Cargo Hook P/N 528-029-01, resistance 1.2 to 1.6 ohms. All other Cargo Hook P/Ns except P/N 528-029-02, resistance 3.0 to 4.0 ohms.	None	N/A	No
21.	Surefire Module (7.10)*	Bent or corroded terminals.	None	N/A	No
22.	Electrical connector (7.5)	Loose, missing, or mutilated contact pins, cracked case, or worn insulator	None	N/A	No
23.	Rigging warning decal (1)	Damage or illegible	None	N/A	Yes
24.	Springs (33)	Cracks or deformation	None	N/A	Yes
25.	Electrical wiring	Deterioration	None	N/A	No
26.	All remaining nuts, bolts, roll pins, cotter pins, washers, heli-coils	Wear, corrosion or deterioration	None	N/A	Yes

Note 1 – For service at Onboard Systems, optional finish: black anodize per MIL-A-8625 Type II, Class 2 after nondestructive inspection. Prepare for anodize by using standard methods.

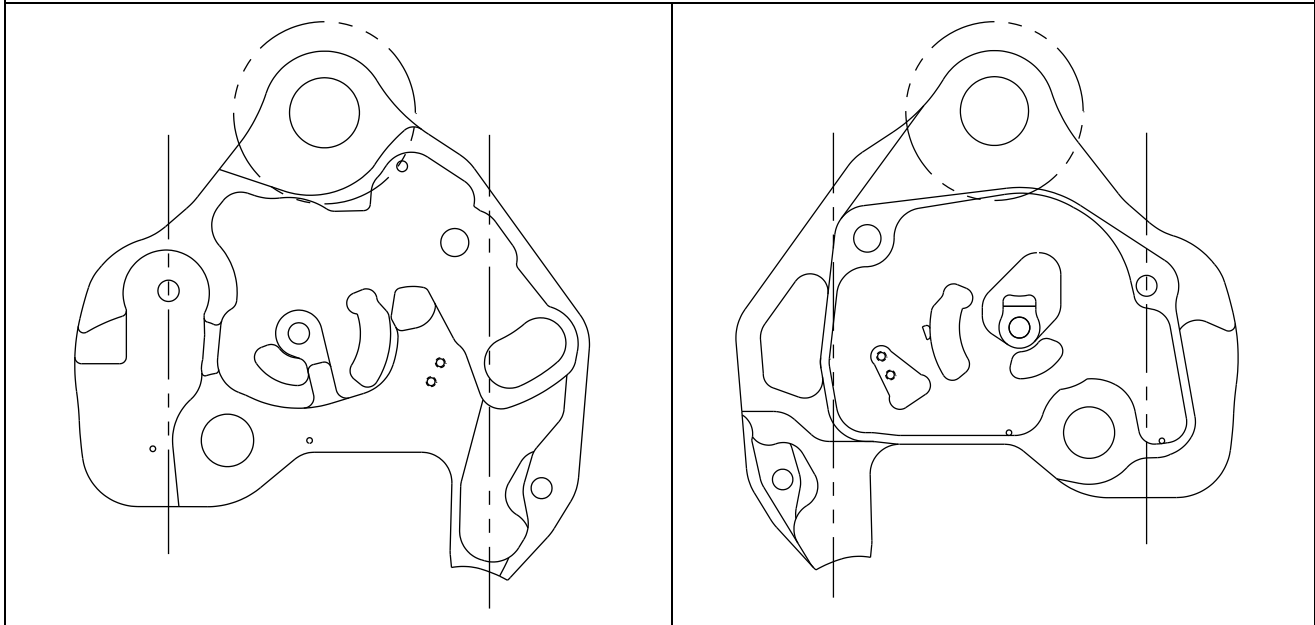
\*Applicable to P/N 528-029-02 only.

**Figure 9.1, Side Plate, Additional Inspection Criteria**

Side Plate, Manual (5.2)



Side Plate, Solenoid (8.2)



Inspection Criteria and Limits

Inside dashed circles – NO corrosion allowed.

Inside dashed circles – Dents, nicks, gouges, and scratches – 0.005 in (0.13 mm) deep.

Inside dashed lines – Dents, nicks, gouges, scratches, and corrosion – 0.010 in (0.25 mm) deep.

Outside dashed lines – Dents, nicks, gouges, scratches, and corrosion – 0.020 in (0.50 mm) deep.

(X) Approved metal stamp locations

Figure 9.2 Cam Assembly (3) Inspection Criteria



*Thoroughly inspect surfaces inside lines for signs of visible wear, dents, corrosion, gouges or nicks. Continued use of a damaged cam may cause inadvertent load release.*



*Repair (including filing, deburring and buffing) is prohibited on all surfaces shown inside lines. Alterations of these surfaces may cause inadvertent load release.*

Figure 9.2.1

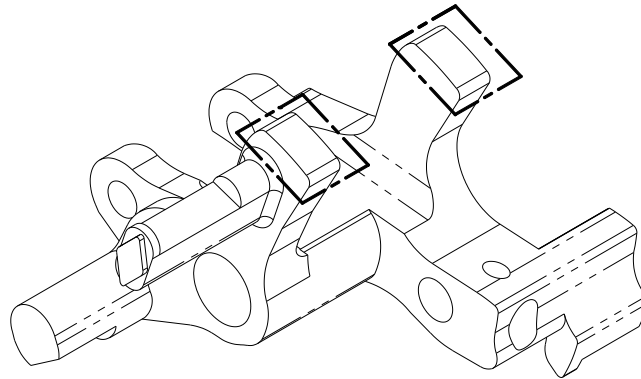
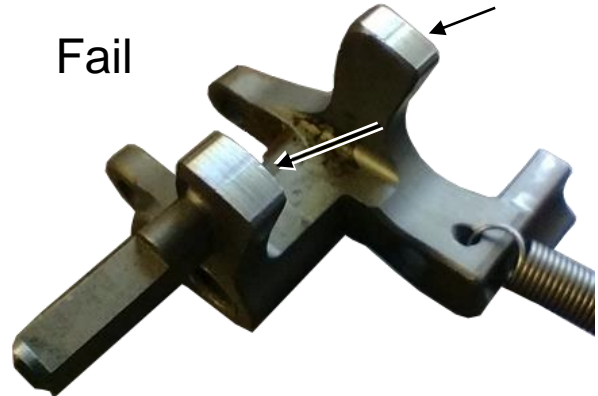


Figure 9.2.2

Pass

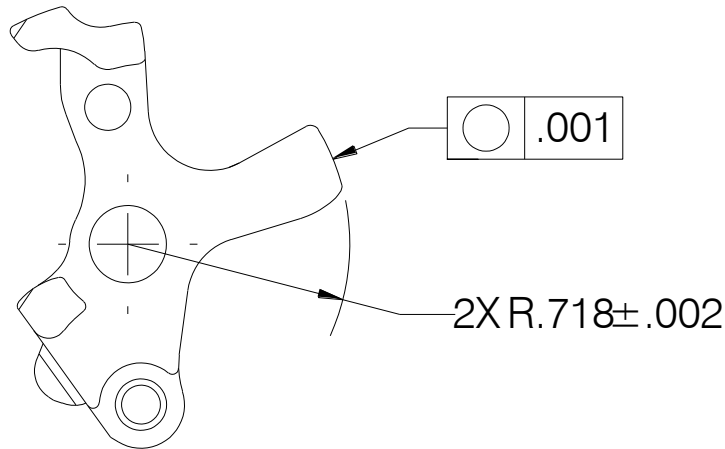


Fail



Continued on next page.

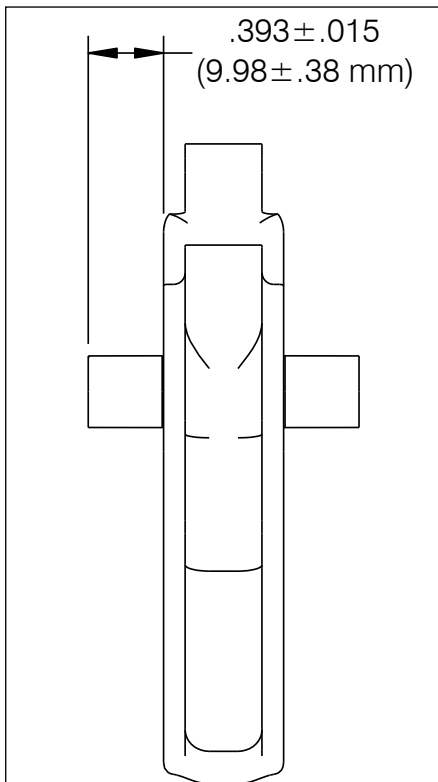
**Figure 9.2.3**



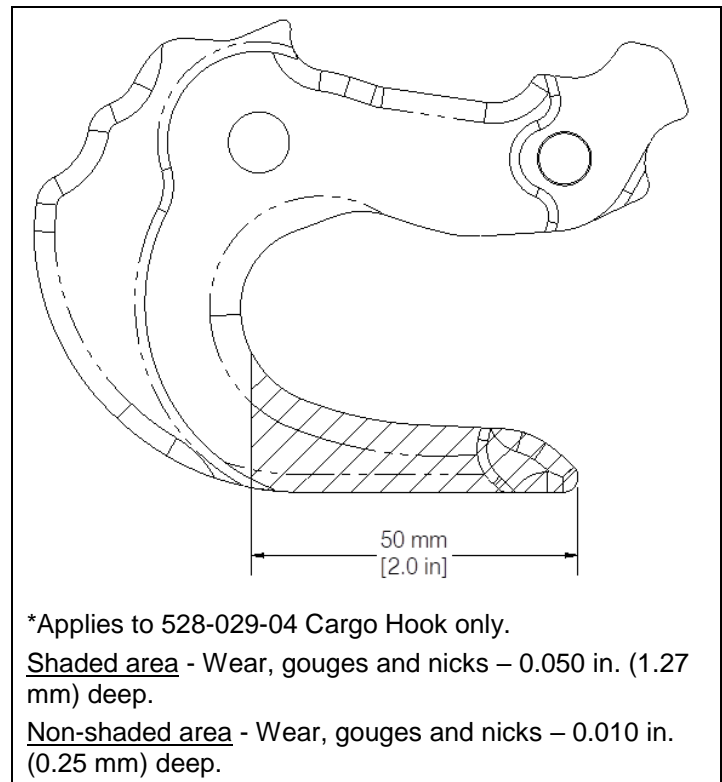
Inspection Criteria and Limits

Inside lines, see figure 9.2.1, gently clean surface by hand using Scotch-Brite (MFG: 3M, MFG P/N: 7447). Visually inspect surface. No dents, corrosion, gouges, or nicks may remain after cleaning, see figure 9.2.2. If the cam passes visual inspection, dimensionally inspect per figure 9.2.3.

**Figure 9.3 Load Beam Shaft Depth**

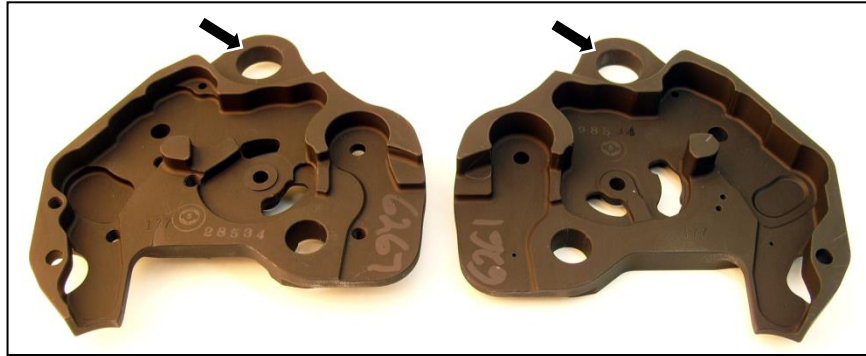


**Figure 9.4 Load Beam Wear, Gouges, and Nicks\***



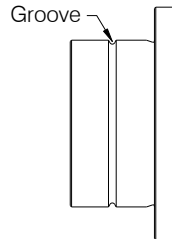


- 9.4 Replace all parts found to be unserviceable or beyond limits.
- 9.5 Measure the top attach bushing hole of side plates (5.2) and (8.2) with a bore gage to determine if the standard attach bushing (5.1, 8.1) is appropriate or if an oversize attach bushing P/N 290-294-01 is required. The oversize attach bushing P/N 290-294-01 may be distinguished from the standard attach bushing by the presence of a groove on the OD.



- 9.6 Install correct attach bushing into side plates (5.2) and (8.2) as follows.

If top attach hole measures:	Use attach bushing:	Installation
Less than .6257 in (15.893 mm)	P/N 290-294-00 (5.1, 8.1)	Install with wet zinc chromate primer using an arbor press. Ensure a continuous fillet seal of primer around bushing flange after installation.
.6264 - .6270 in (15.910 - 15.926 mm)	P/N 290-294-01*  * Oversized Attach Bushing P/N 290-294-01 is identified by a groove on its OD as shown.	
.6257 - .6263 in (15.893 - 15.908 mm)	P/N 290-294-00 (5.1, 8.1)	Install with Loctite 680 adhesive using an arbor press. Ensure a continuous fillet seal of adhesive around bushing flange after installation.
.6271 - .6285 in (15.928 - 15.954 mm)	P/N 290-294-01	



- 9.7 Press bearing (8.4) into side plate (8.2) with wet zinc chromate primer using an arbor press. Split in bearing must be oriented towards the top of the hook. Press roll pin (8.3) into side plate using an arbor press.



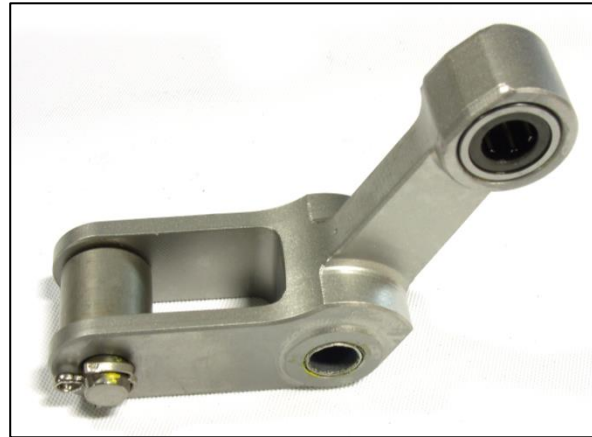
- 9.8 Press bearing (5.5) into side plate (5.2) with wet zinc chromate primer using an arbor press. Split in bearing must be oriented towards the top of the hook.



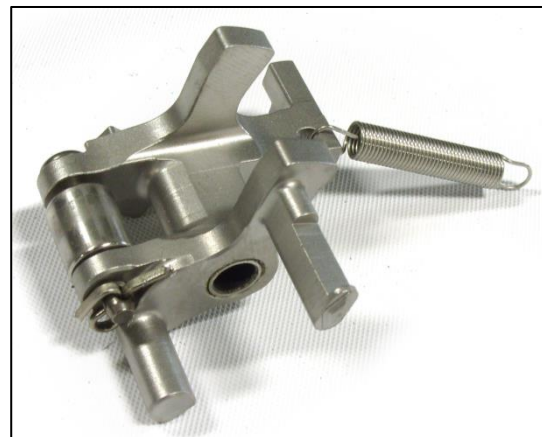
- 9.9 Press roll pin (5.3) into side plate using an arbor press. Install two helicoils (5.4) into side plate. Break and remove helicoil tangs.



- 9.10 Assemble toggle (4): Press two bushings (4.5) into load beam roller (4.1) with wet zinc chromate primer using an arbor press. Press two bushings (4.5) into toggle (4.2) with wet zinc chromate primer using an arbor press. Press bearing (4.6) into toggle using an arbor press. Capture load beam roller in toggle using pin (4.4). Ensure pin is installed as shown. Secure pin with cotter pin (4.3).



- 9.11 If disassembled, assemble cam (3): Press two bushings (3.7) into roller (3.1) with wet zinc chromate primer using an arbor press. Press two bushings (3.6) into cam (3.2) with wet zinc chromate primer using an arbor press. Capture roller with pin (3.4) and secure with cotter pin (3.3) as shown. Attach spring (3.5) to cam.



- 9.12 Press bearing (6.2) into manual release lever (6.1) with wet zinc chromate primer using an arbor press.



- 9.13 Install bolt (15) through side plate (8.2). Apply a light coat of Mil-G-23827 grease to indicated surfaces of side plate.



- 9.14 Place cam assembly (3) over the bolt. Extend spring (3.5) over roll pin (8.3).



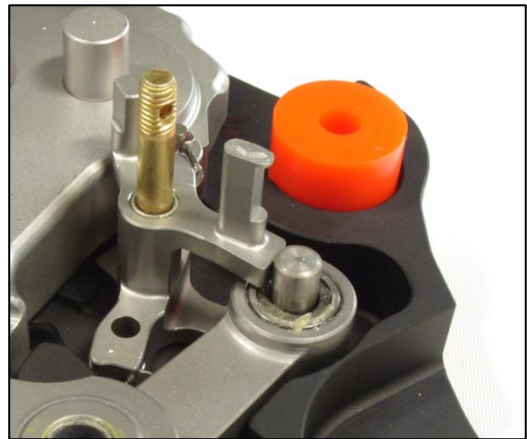
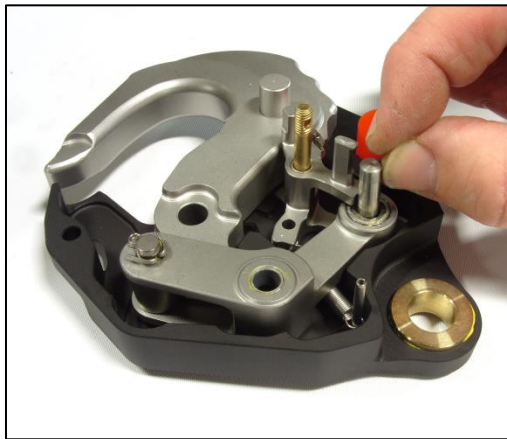
- 9.15 Install load beam assembly (2) and bumper (32). Rotate cam (3) clockwise to install load beam.



- 9.16 With the load beam open all the way, install toggle assembly (4).



- 9.17 Apply Mil-G-23827 grease to bearing (4.6) and install cam roller pin (13).



**! WARNING**

*Ensure that cam roller pin (13) is installed in the toggle assembly, omitting installation of cam roller pin will cause cargo hook to not function properly and be damaged.*

- 9.18 Check for and remove FOD if present

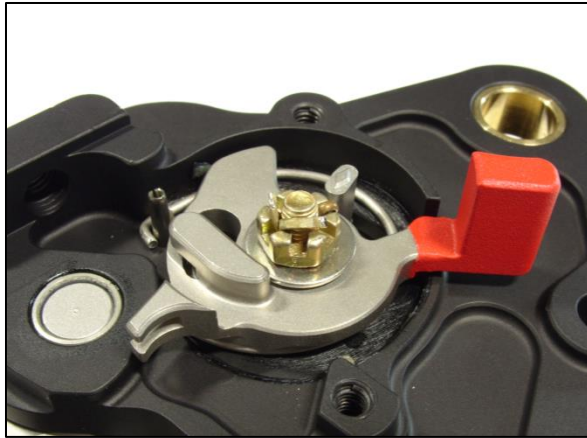
- 9.19 Place Side Plate Assembly (5) over the assembly, lining up the bolt (15), roll pin (8.3), and the load beam shaft (2.1).



- 9.20 Apply Mil-G-23827 grease to side plate surfaces that will contact the spring and install spring (33) capturing cam and roll pin.



- 9.21 Place manual release lever assembly over bolt (15). Secure using washer (28), nut (18), and cotter pin (22). Install second spring (33) capturing the roll pin and inserting the looped end into the slot on the manual release lever assembly (as shown).



**CAUTION**

*Both springs must be installed.*

**CAUTION**

*Do not actuate the manual release lever without the manual release cover installed. Actuating the manual release lever may result in the spring being ejected from the hook.*

- 9.22 Apply a corrosion preventative compound to faying surfaces of armor plates (11 and 12) and install using bolt (26) and nut (20).

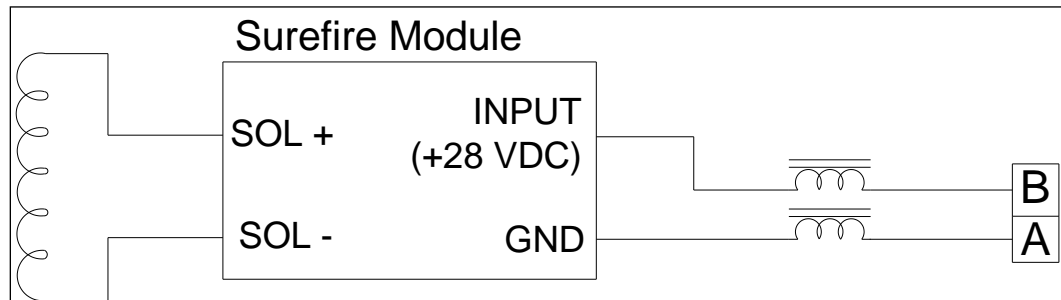


- 9.23 Install solenoid cam (7.2) onto solenoid using screws (7.9). Apply Loctite 262 to screw threads. Safety wire screws as shown using .020 - .032 in [0.5 - 0.8 mm] diameter safety wire. If the diode (7.4) and solenoid leads (7.6) were removed from the connector (7.5) re-solder/install prior to assembling into cover. Install the connector using the O-ring and nut included with the connector. Ensure the connector is installed in the proper orientation as noted on disassembly. Place the solenoid into the solenoid cover (7.3). For cargo hook P/N 528-029-04, torque connector nut to 40-46 in-lb [4.5-5.2 N-m].



- 9.24 For cargo hook P/N 528-029-02 solder the wires from the solenoid to the inner two terminals of the Surefire Module (7.10). Route each wire from the connector to the Surefire Module through a ferrite cable core (7.13) twice. Solder the wire from connector pin B to the INPUT terminal (terminal located nearest to the connector) of the Surefire Module and solder the wire from the connector pin A to the GND terminal (terminal located furthest from the connector), reference schematic below. Use Loctite 598 RTV silicone on the ferrite cable cores to secure them to the inside of the cover.

If the Surefire Module was removed, apply a small amount of Loctite 598 RTV silicone to its faying surface with solenoid cover and re-install it with the screw (7.11) and nut (7.12).





- 9.25 Apply Loctite 598 RTV silicone to solenoid mounting studs and place S/N Tag (7.1) over mounting studs and secure with two washers (7.8) where applicable, and nuts (7.7). Torque nuts to 20-25 in-lb [2.3-2.8 N-m] plus drag torque. Install screw (29) and rigging warning decal (1) as shown.



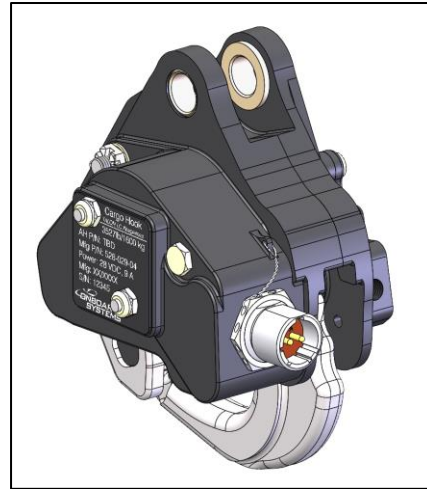
- 9.26 Install solenoid assembly onto cargo hook. Install bolt (16), washer (23), and nut (24). Torque nut to 15 in-lb [1.7 N-m] then rotate to next castellation and install cotter pin (21). Install bolt (25), washer (19), and nut (20). Torque to 20-25 in-lb [2.3-2.8 N-m]. For cargo hook P/N 528-029-00, -01, -02, and -60 the bolt (16) is installed from the same side as the solenoid assembly (7). On P/Ns 528-027-01 and 528-029-04 bolt (16) is installed from the side opposite the solenoid assembly and the guard base (10) is captured underneath the head (as shown in Figure 13.1).



- 9.27 Install manual release cover (14) using two screws (27). The screws may be loosely installed as the cover will be removed for the ATP.



- 9.28 For P/N 528-029-00, 528-029-01, 528-029-02, 528-029-04, and 528-027-01 hooks only: safety wire connector nut to cover with .020 - .032 diameter safety wire as shown. Heat shrink over safety wire is optional.

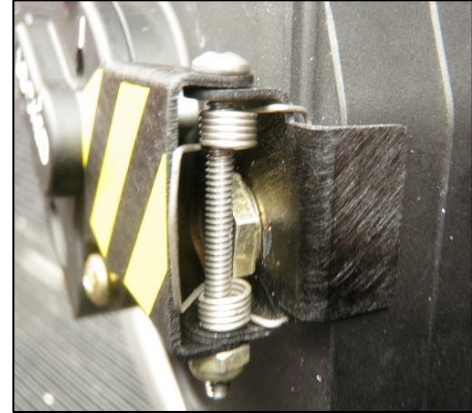
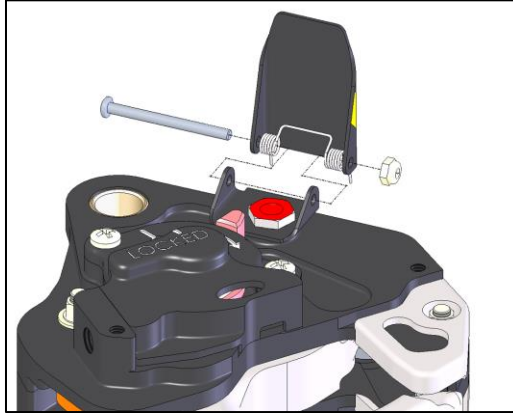


- 9.29 For P/Ns 528-027-01 and 528-029-04 only:


1. Install guard base (9) with bolt (16), nut (24) and washer (23). Torque nut (24) to 15 in-lb [1.7 N-m]. Rotate to next castellation and install cotter pin



2. Bend two “arms” of the spring (34) inward and install under guard cover (9) using screw (31) and nut (17) as shown. Torque nut to 10 - 12 in-lb [1.1-1.4 N-m].



- 9.30 Perform Acceptance Test Procedures as listed in this manual.
- 9.31 Fill out and affix Overhaul Label (P/N 215-260-00).

	<b>Component Maintenance Manual</b>	Document Number 122-017-00	Revision 32
		Date 01/03/23	Page 28 of 36

## 10.0 Acceptance Test Procedure


- 10.1 When the Cargo Hook is overhauled or the side plates (5.2 and 8.2) are separated, the Cargo Hook must be subjected to the following acceptance test procedure (ATP) steps before being returned to service.
- 10.2 Examine the Cargo Hook externally for security of the lock wire, cotter pins and fasteners.
- 10.3 Use an appropriate insulation resistance tester to test the resistance between each pin and the base of the connector (7.5). The readings should not be less than 2 mega-ohms.
- 10.4 For all configurations except P/N 528-029-02 use a multi-meter to check the resistance between pins A and B of the electrical connector. Resistance should be:

Applicable P/Ns	Resistance
528-027-01, 528-029-00, 528-029-04, and 528-029-60	3 – 4 ohms
528-029-01	1.2 – 1.6 ohms

- 10.5 Remove the two screws (27) and Manual Release Cover (14) and install a manual release test cable. Replace the Manual Release Cover and screws.
- 10.6 Suspend the hook from a test rig capable of loading the Cargo Hook to 9,000 pounds (4082 kg). Use a steel ring to apply the load to the load beam.
- 10.7 Connect a power supply (see below for required VDC output) with a momentary release switch wired into the positive wire, to the connector (7.5), and an in-line current meter. Connect the negative lead to pin A and the positive lead to pin B. Set the voltage as follows:

Applicable P/Ns	Voltage
528-027-01, 528-029-00, 528-029-02, 528-029-04, 528-029-60	20 VDC $\pm$ 0.1
528-029-01	10.25 VDC $\pm$ 0.1

- 10.8 With no load on the load beam, operate the manual release lever. The load beam should fall open and stay in the open position. Push the load beam up and closed. The load beam should automatically latch. Repeat step.

	<b>Component Maintenance Manual</b>	Document Number 122-017-00	Revision 32
		Date 01/03/23	Page 29 of 36

- 10.9 Check the electrical release function of the Cargo Hook.

**For all configurations except 528-029-02 perform the following.**

With no load on the load beam, release the Cargo Hook with the electrical release. The load beam should fall open and stay in the open position. Push the load beam up and closed. The load beam should automatically latch. Repeat step.

## CAUTION

*Damage to the Cargo Hook release solenoid can occur if the release switch is operated for more than 20 seconds continuously.*

**For the 528-029-02 configuration, perform the following.**

## NOTICE

*The 528-029-02 cargo hook includes an electronic delay of approximately ½ second. It is necessary to press and hold the release switch.*


Actuate the release switch very briefly without holding it down (less than ½ second). The load beam should remain closed and the mechanism should not audibly cycle.

Actuate and hold the release switch for a few seconds. The load beam should fall to the open position after approximately ½ second and then should continue to audibly cycle repeatedly.

- 10.10 Load a suitable load ring onto the load beam (2.2) and push up load beam until it latches. Gradually load the Cargo Hook with the test rig to 9,000 pounds (4082 kg). Hold the load for 1 minute. The load beam should hold the load without unlatching. Reduce the load to zero.

## CAUTION

*Do not release the proof test load electrically or manually. Decrease the load gradually, using the test machine, after completion of the proof load test.*

	<b>Component Maintenance Manual</b>	Document Number 122-017-00	Revision 32
		Date 01/03/23	Page 30 of 36

- 10.11 Load the Cargo Hook using a steel ring that is free to drop clear of the load beam. Gradually load the Cargo Hook to 3,600 pounds (1633 kg). Using a spring scale or equivalent, pull the manual release cable. The load beam should unlatch and the steel ring should slide off the load beam. Verify the required release force is between 3.5 pounds (15.5 N) and 8 pounds (35.5 N). Push the load beam up and closed. The load beam should automatically latch and the hook lock indicator should align with the line on the manual release cover. Repeat the test at 2,000 pounds (907 kg) and 600 pounds (272 kg).

## CAUTION


*Use of a nylon sling is not recommended for load release tests as recoil may cause damage to the Cargo Hook.*

- 10.12 Load the Cargo Hook using a steel ring that is free to drop clear of the load beam. Gradually load the Cargo Hook to 3,600 pounds (1633 kg). Press the electrical release button (press and hold for P/N 528-029-02 cargo hook). The load beam should unlatch and the steel ring should slide off the load beam. Push the load beam up and closed. The load beam should automatically latch and the hook lock indicator should align with the line on the manual release cover. Verify that the current draw is between 5 and 9 amps\*. Repeat the test at 2,000 pounds (907 kg) and 600 pounds (272 kg).

\*The 528-029-02 configuration delivers this current in rapid pulses which may register as a lower current value on some ammeters due to averaging.

- 10.13 Remove the Cargo Hook from the test stand. Remove the manual release cable and replace the Manual Release Cover (14) and screws (27).
- 10.14 End of Acceptance Test Procedure.
- 10.15 For service at Onboard Systems, optionally use the following Onboard Systems factory acceptance test procedures:

Acceptance Test Procedure	Applicable P/Ns
180-172-00	528-027-01, 528-029-00, 528-029-02, 528-029-04, 528-029-60
180-180-00	528-029-01

	<b>Component Maintenance Manual</b>	Document Number 122-017-00	Revision 32
		Date 01/03/23	Page 31 of 36

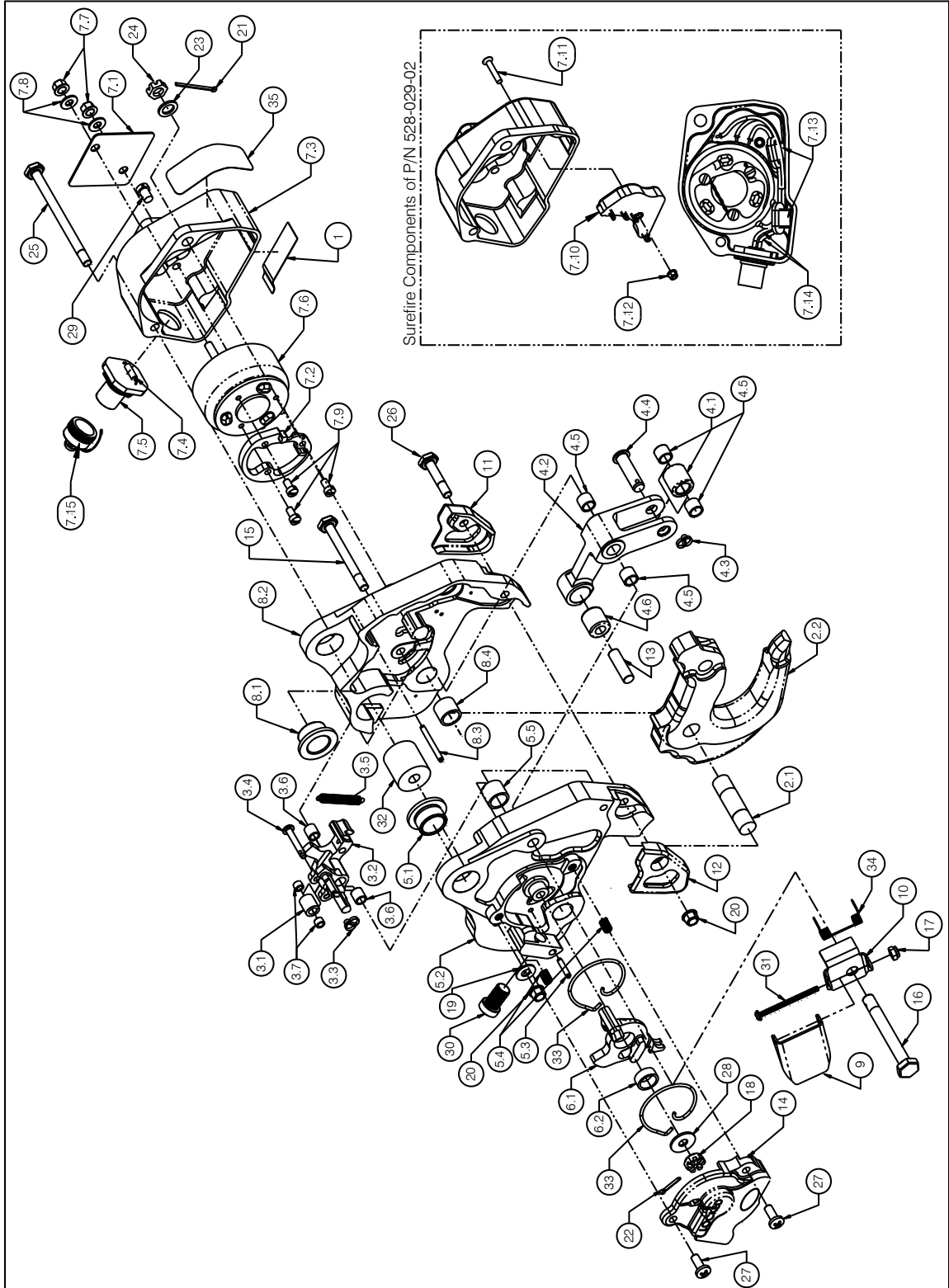
## 11.0 Troubleshooting

11.1 The following section lists symptoms and probable causes to aid in equipment troubleshooting.

Symptom	Probable Cause	Remedy
Failure to operate electrically	Damaged or defective diode (7.4) or Surefire Module (7.10) or solenoid (7.6). (diode is applicable to all hooks except P/N 528-029-02, Surefire Module is used in P/N 528-029-02 only).	Check for proper resistance across connector pins A and B per section 11.4. If out of tolerance, remove the Solenoid Assembly (7) and disconnect the diode. Re-check for proper resistance. Replace diode or solenoid as necessary. For P/N 528-029-02, remove the Solenoid Assembly from the Cargo Hook and check the resistance across the (+) and (-) Solenoid terminals of the Surefire Module for 3 – 4 ohms. Replace Surefire Module or solenoid (as necessary).
	Damaged or loose wiring.	Check for proper continuity across connector pins A and B per table 9.1. Remove the Solenoid Assembly (7) and repair wiring.
	Release switch not held down long enough (P/N 528-029-02 only).	Hold the release switch for a longer time. The 528-029-02 cargo hook includes a Surefire Module (7.10) which incorporates an electronic delay of approximately ½ second after which time the hook solenoid will activate repeatedly. If the release switch is not held down long enough the solenoid will not activate.
During the Acceptance Test Procedure, the manual release cable force exceeds requirements	Friction in internal mechanism.	Check operation of unit using the manual release lever. Disassemble and inspect internal mechanism. Check all bearing joints for free movement. Check cam assembly (3) for denting/ damage. Check toggle roller and pin for denting/ damage. Replace as necessary.

## 12.0 Illustrated Parts List

Figure 13.1 Cargo Hook Parts







# Component Maintenance Manual

Document Number  
122-017-00

Revision  
32

Date  
01/03/23

Page  
33 of 36

**Table 13.1, Cargo Hook Parts**

Item	Part No.	Description	528-029-00	528-029-01	528-029-02	528-029-60	528-029-04	528-027-01	Overhaul Kit 212-024-00	Overhaul Kit 212-072-00
1	215-240-00	Rigging Warning Decal	1	1	1	1	1	1	1	1
2 <sup>1</sup>	232-161-00	Load Beam Assembly	1	1	1	1	-	1	-	-
2 <sup>1</sup>	232-161-02	Load Beam Assembly	-	-	-	-	1	-	-	-
2.1	290-640-00	Load Beam Shaft	1	1	1	1	-	1	-	-
2.1	290-640-01	Load Beam Shaft	-	-	-	-	1	-	-	-
2.2	290-831-00	Load Beam	1	1	1	1	1	1	-	-
3 <sup>1</sup>	232-162-00	Cam Assembly	1	1	1	1	1	1	1	1
3.1	290-603-00	Roller	1	1	1	1	1	1	-	-
3.2	290-832-00	Cam	1	1	1	1	1	1	-	-
3.3	510-417-00	Cotter Pin	1	1	1	1	1	1	-	-
3.4	510-495-00	Pin	1	1	1	1	1	1	-	-
3.5	514-032-00	Spring	1	1	1	1	1	1	-	-
3.6	517-009-00	Bushing	2	2	2	2	2	2	-	-
3.7	517-031-00	Bushing	2	2	2	2	2	2	-	-
4 <sup>1</sup>	232-185-00	Toggle Assembly	1	1	1	1	-	1	-	-
4 <sup>1</sup>	232-185-01	Toggle Assembly	-	-	-	-	1	-	-	-
4.1	290-438-00	Load Beam Roller	1	1	1	1	1	1	-	-
4.2	290-838-00	Toggle	1	1	1	1	1	1	-	-
4.3	510-417-00	Cotter Pin	1	1	1	1	1	1	1	1
4.4	510-494-00	Pin	1	1	1	1	-	1	1	-
4.4	509-004-00	Pin	-	-	-	-	1	-	-	1
4.5	517-021-00	DU Bushing	4	4	4	4	4	4	4	4
4.6	517-060-00	Bearing	1	1	1	1	1	1	1	1
5 <sup>1</sup>	232-194-00	Side Plate Assembly, Manual Release	1	1	1	1	1	1	-	-
5.1	290-294-00	Attach Bushing	1	1	1	1	1	1	1	1
5.2	290-897-00	Side Plate, Manual Release	1	1	1	1	1	1	-	-
5.3	510-203-00	Roll Pin	1	1	1	1	1	1	1	1
5.4	510-210-00	Helicoil	2	2	2	2	2	2	2	2
5.5	517-010-00	Bearing	1	1	1	1	1	1	1	1
6 <sup>1,3</sup>	232-195-00	Manual Release Lever Assembly	-	-	-	-	1	1	-	-
6 <sup>1,3</sup>	232-195-01	Manual Release Lever Assembly	1	1	1	1	-	-	-	-
6.1	290-899-00	Manual Release Lever	-	-	-	-	1	1	-	-
6.1	290-899-01	Manual Release Lever	1	1	1	1	-	-	-	-
6.2	517-054-00	Bearing	1	1	1	1	1	1	1	1
7 <sup>1</sup>	232-212-00	Solenoid Assembly	1	-	1	-	-	-	-	-
7 <sup>1</sup>	232-212-01	Solenoid Assembly	-	1	-	-	-	-	-	-





# Component Maintenance Manual

Document Number  
122-017-00

Revision  
32

Date  
01/03/23

Page  
35 of 36

Item	Part No.	Description	528-029-00	528-029-01	528-029-02	528-029-60	528-029-04	528-027-01	Overhaul Kit 212-024-00	Overhaul Kit 212-072-00
14	290-898-01	Manual Release Cover	1	1	1	1	1	1	-	-
15	290-901-00	Bolt	1	1	1	1	-	1	1	1
15	509-003-00	Bolt	-	-	-	-	1	-	-	1
16	290-913-00	Bolt	1	1	1	1	-	1	1	-
16	509-002-00	Bolt	-	-	-	-	1	-	-	1
17	510-029-00	Nut	-	-	-	-	1	1	-	-
18	510-082-00	Nut	1	1	1	1	1	1	1	1
19	510-095-00	Washer	1	1	1	1	1	1	1	1
20	510-102-00	Nut	2	2	2	2	2	2	2	2
21	510-115-00	Cotter Pin	1	1	1	1	1	1	1	1
22	510-125-00	Cotter Pin	1	1	1	1	1	1	1	1
23	510-100-00	Washer	-	-	-	-	1	-	-	1
23	510-219-00	Washer	1	1	1	1	-	-	1	-
23	510-983-00	Washer	-	-	-	-	1	1	-	-
23	540-796-00	Washer	-	-	-	-	1	-	-	1
24	510-259-00	Nut	1	1	1	1	-	1	1	1
24	510-796-00	Nut	-	-	-	-	1	-	-	1
25	510-375-00	Bolt	1	1	1	1	1	1	1	1
26	510-376-00	Bolt	1	1	1	1	1	1	1	1
27	510-493-00	Screw	2	2	2	2	2	2	2	2
28	510-516-00	Washer	1	1	1	1	1	1	1	1
29	510-755-00	Screw	1	1	1	1	-	1	1	-
30	510-961-00	Screw	-	-	-	-	1	1	-	-
31	510-963-00	Screw	-	-	-	-	1	1	-	-
32	514-031-00	Bumper	1	1	1	1	1	1	1	1
33	514-058-00	Torsion Spring	2	2	2	2	2	2	2	2
34	514-089-00	Spring	-	-	-	-	1	1	-	-
35	215-336-00	Surefire Notice Decal	-	-	1	-	-	-	1	-
36 <sup>2</sup>	215-260-00	Overhaul Label	-	-	-	-	-	-	1	1

<sup>1</sup> Item not illustrated as an assembly.


<sup>2</sup> Item not illustrated.

<sup>3</sup> P/N 232-195-01 supersedes P/N 232-195-00 these parts are interchangeable.

<sup>4</sup> Diode P/N 340-035-00 supersedes diode P/N 340-027-00.

<sup>5</sup> For field installation use 215-253-10 (for 528-029-00) or 215-254-10 (for 528-029-10). Steel stamp or engrave data in blank fields.

<sup>6</sup> Connector Cap w/ Chain is optional and can be removed from cargo hook (applicable to P/N 528-027-01 only).

	Component Maintenance Manual	Document Number 122-017-00	Revision 32
		Date 01/03/23	Page 36 of 36

### 13.0 Instructions for Returning Equipment to the Factory

- 13.1 If an Onboard Systems product must be returned to the factory for any reason (including returns, service, repairs, overhaul, etc.) obtain an RMA number before shipping your return.



*An RMA number is required for all equipment returns.*

- To obtain an RMA, please use one of the listed methods.
  - Contact Technical Support by phone or e-mail ([Techhelp@OnboardSystems.com](mailto:Techhelp@OnboardSystems.com)).
  - Generate an RMA number at our website: <http://www.onboardsystems.com/rma.php>
- After you have obtained the RMA number, please be sure to:
  - Package the component carefully to ensure safe transit.
  - Write the RMA number on the outside of the box or on the mailing label.
  - Include the RMA number and reason for the return on your purchase or work order.
  - Include your name, address, phone and fax number and email (as applicable).
  - Return the components freight, cartage, insurance and customs prepaid to:  
Onboard Systems International, LLC  
13915 NW 3rd Court  
Vancouver, Washington 98685  
USA  
Phone: 360-546-3072